

INSTRUCTION MANUAL
ILLUSTRATED PARTS LIST

FOR

SINGER

MACHINES

2491D 200A
300A

THE SINGER COMPANY

Contents

Instruction Manual	1
Illustrated Parts List	15
Model 2491D200A (For Medium Weight Materials)	16
1.Arm Bed Components	16
2.Main Shaft & Thread Take-up Components	18
3.Needle Bar & Thread Tension Components	20
4.Presser Bar Components	22
5.Hook Driving Shaft Components	24
6.Feed Mechanism Components	26
7.Feed Regulating Components	28
8.Lubrication Components	30
9.Oil Reservoir & Knee Lifter Components	32
10.Machine Head Accessories (1)	34
Machine Head Accessories (2)	36
11.Machine Stand, Table & Electric Appliance Components	38
Model 2491D300A (For Heavy Weight Materials)	40

INSTRUCTION MANUAL

1. Never operate the machine unless its oil pan has been filled with oil.
2. After setting up the machine, check the direction of motor rotation. To check it, turn the handwheel by hand to bring the needle down, and turn the power switch ON while observing the handwheel. (The handwheel should turn counterclockwise as observed from the handwheel side.)
3. Do not use a larger motor pulley for the first one month.
4. Confirm that the voltage and phase (single or 3-phase) are correct by checking them against the ratings shown on the motor nameplate.

OPERATION PRECAUTIONS

1. Keep your hands away from the needle when you turn the power switch ON or while the machine is operating.
2. Do not put your fingers into the thread take-up cover while the machine is operating.
3. Be sure to turn the power switch OFF before tilting the machine head or removing the V belt.
4. When an operator leaves from the machine, make sure to turn off the power.
5. During operation, be careful not to allow your or any other person's head or hands to come close to the handwheel, V belt, bobbin winder or motor. Also, do not place anything close to them. Doing so may be dangerous.
6. If your machine is provided with a belt cover, finger guard or any other protectors, do not operate your machine with any of them removed.
7. Don't clean the face of machine head with thinner.

INSTALLATION (Fig.1, Fig.2, Fig.3, Fig.4)

* Installing the oil pan

- 1) The oil pan should rest on the four corners of the machine table groove.
- 2) Fix two rubber seats ① on side A (operator's side) using nails ② as illustrated above. Fix two cushion seats ③ on side B (hinged side) using nails ②. Then place oil pan ④ on the fixed seats. (Fig.1, Fig.2)
- 3) Fit hinge ① into the opening in the machine bed, and fit the machine head to table rubber hinge ② before placing the machine head on cushions ③ on the four corners. (Fig.3, Fig.4)

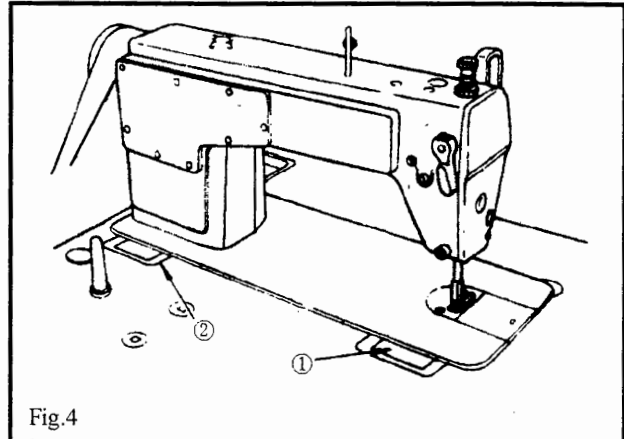
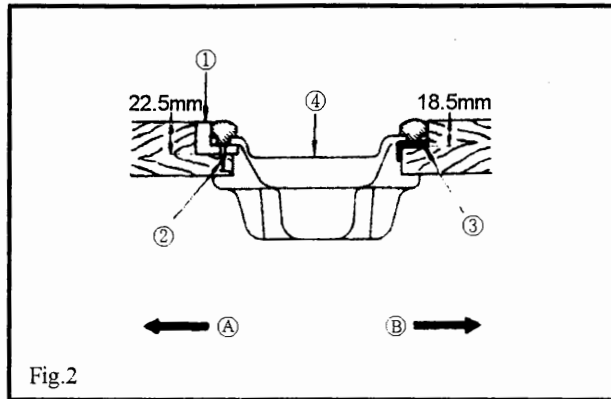
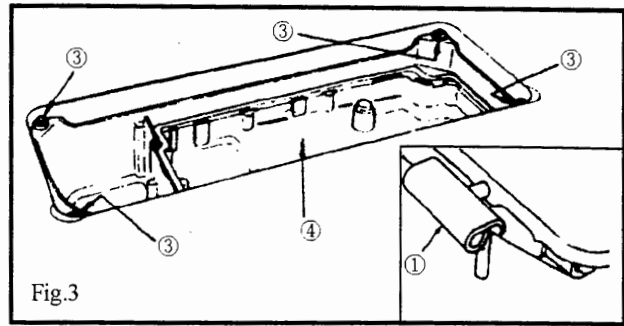
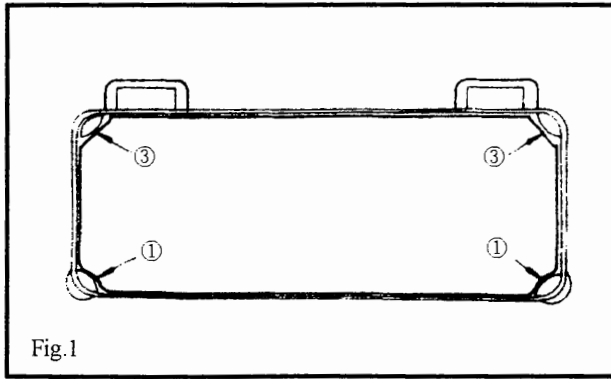

1. Information on lubrication (Fig.5)

* Before starting the machine

- 1) Fill oil pan ① with sewing machine oil (SINGER "C" oil) up to HIGH mark ④.
- 2) When the oil level lowers below LOW mark ③, refill the oil pan with the specified oil.
- 3) When you operate the machine after lubrication, you will see splashing oil through oil sight window ② if the lubrication is adequate.
- 4) Note that the amount of the splashing oil is unrelated to the amount of the lubricating oil.

* Precaution

When you first operate your machine after set up or after an extended period of disuse, run your machine at 3,000 s.p.m. to 3,500 s.p.m. for about 10 minutes for the purpose of break-in.

2. Adjusting the amount of oil supplied to the face plate parts (Fig.6)

- 1) Adjust the amount of oil supplied to the thread take-up and needle bar crank ② by turning adjust pin ①.
- 2) The minimum amount of oil is reached when marker dot ④ is brought close to needle bar crank ② by turning the adjust pin in direction ③.
- 3) The maximum amount of oil is reached when marker dot ④ is brought to the position just opposite from the needle bar crank by turning the adjust pin in direction ⑤.

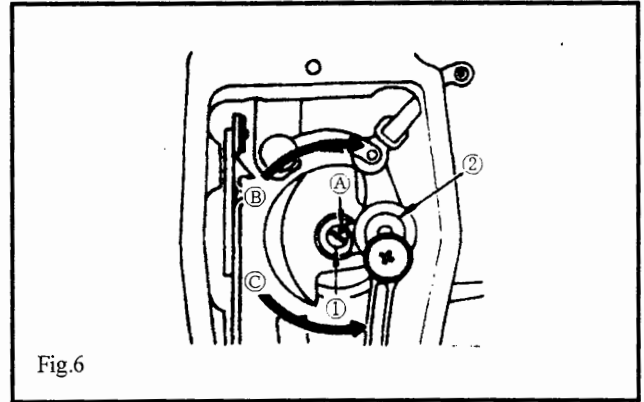
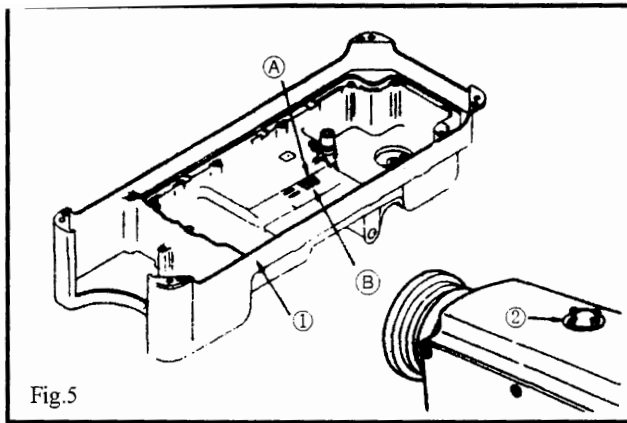

3. ADJUSTING THE AMOUNT OF OIL SUPPLIED TO THE HOOK (Fig. 8, Fig. 9)

- 1) After cooling, the machine may be idling for three minutes (operating continued properly).
 - 2) The amount of oil confirmed paper must be inserted in the state when the machine is operating. (Fig.7)
 - 3) Oil in the oil pan is confirmed within HIGH and LOW.
 - 4) The amount of oil confirmed is for five seconds (please use the clock with the second)
- * The proper amount of oil manual (Fig.8)
- 1) The amount of oil can be adjusted according to the different sewing process but it must be suitable amount.
- * Otherwise the hook will generate heat or the sewing material will be contaminated.
- 2) Use the amount of confirmed paper for three times to observe the amount of oil. Adjust the screw until the mark on the paper hasn't changed.
- * Adjusting the amount of oil supplied to the hook (Fig.9)
- 1) More oil is supplied as oil amount adjust screw mounted on the hook driving shaft is turned toward + in direction A. As the oil amount adjust screw is turned toward-in direction B, the amount of oil supplied will be decreased.
 - 2) After adjusted, the machine must be idling for thirty seconds. It can be confirmed the state of oil supplied.

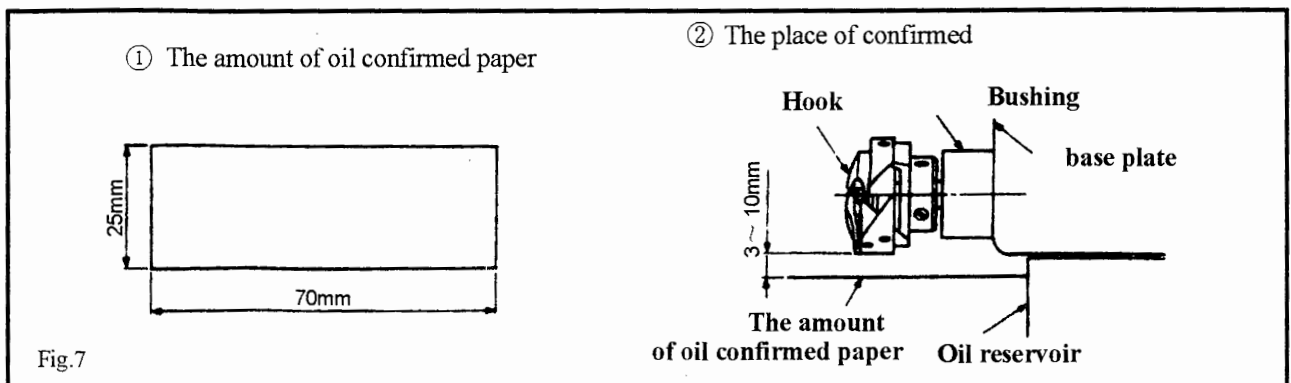

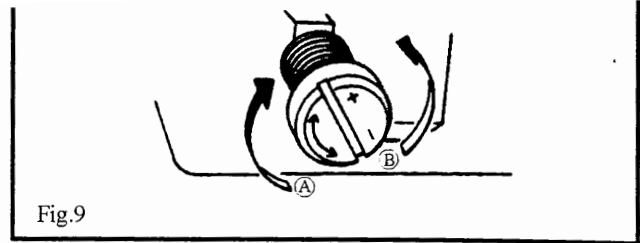
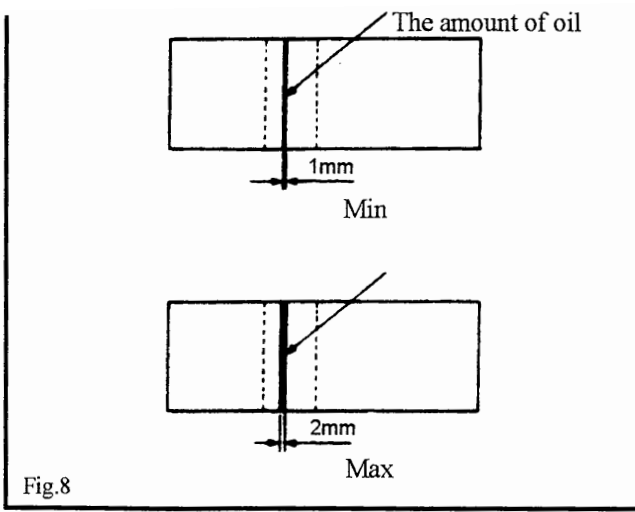

- * Turn the motor power OFF before starting to attach the needle.
- A needle of 1955-01 (DP × 5) #14 should be used. Select a proper needle size according to the count of thread and the type of material used.
- 1) Turn the handwheel until the needle bar reaches the highest point of its stroke.
 - 2) Loosen screw ②, and hold needle ① with its indented part (A) facing exactly to the right in direction (B).
 - 3) Insert the needle in the direction of the arrow until it will go no further.
 - 4) Securely tighten screw ②.
 - 5) Check that long groove (C) of the needle is facing exactly to the left in direction (D).

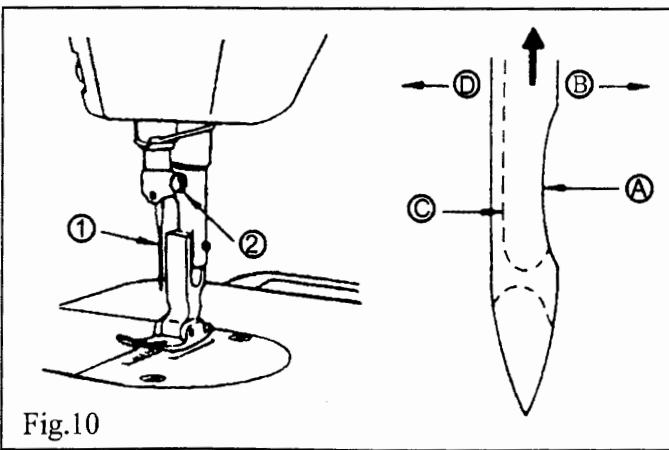

5.SETTING THE BOBBIN INTO THE BOBBIN CASE (Fig.11)

- 1) Hold the bobbin in a way that the thread open end is directed to the left as observed from you, and set the bobbin into the bobbin case.
- 2) Pass the thread through thread slit (A), and pull the thread in direction (C). By so doing, the thread will pass under the tension spring and come out from notch (B).
- 3) Check that the bobbin rotates in the direction of the arrow when thread (C) is pulled.

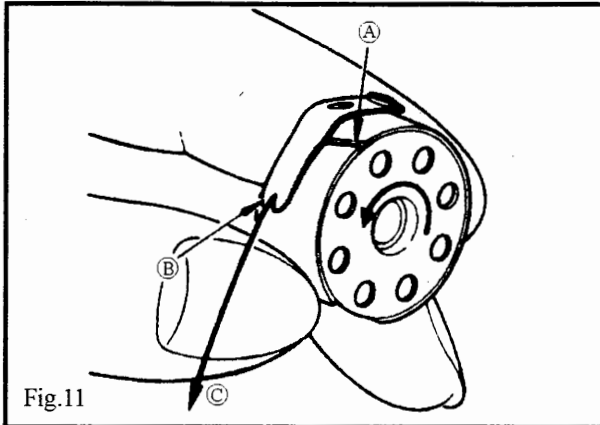

Fig.11

6.THREADING THE MACHINE HEAD (Fig.12)

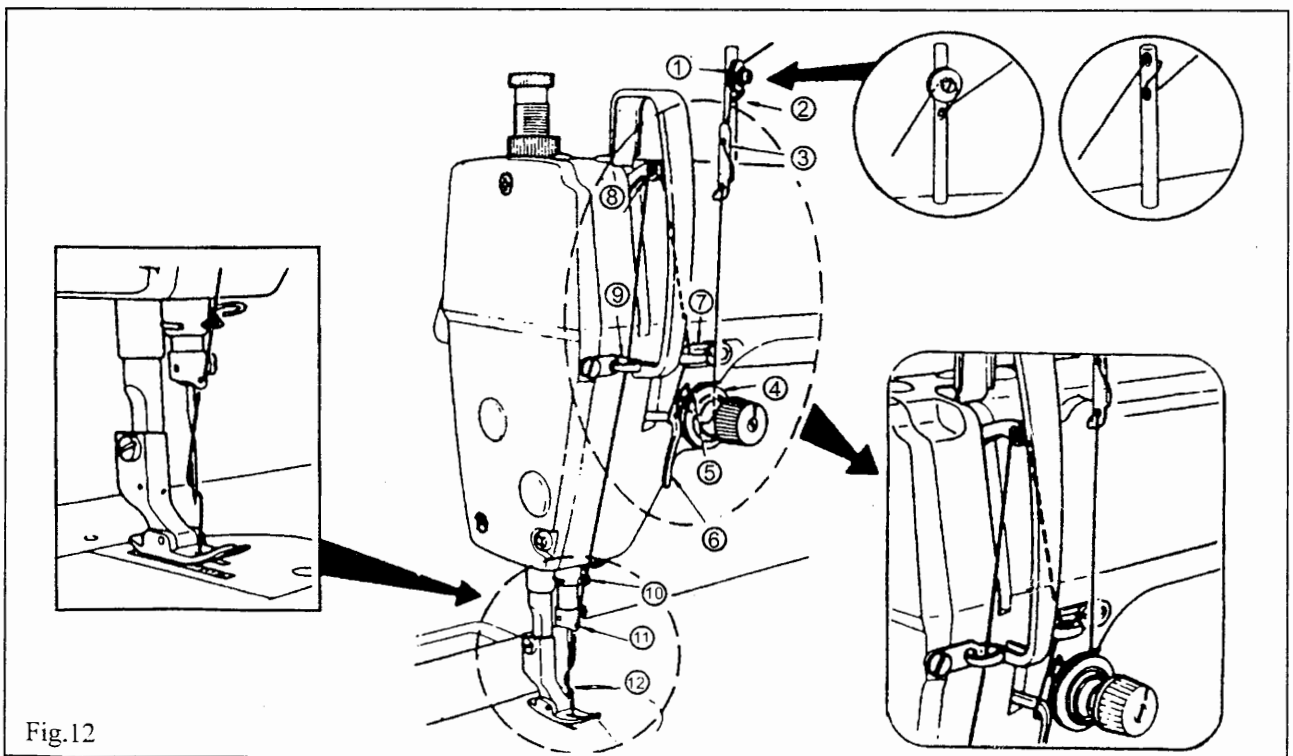
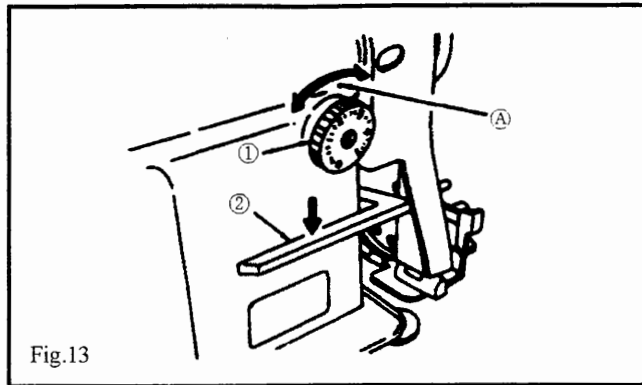

Fig.12

7. ADJUSTING THE STITCH LENGTH (Fig.13)

- 1) Turn stitch length dial ① in the direction of the arrow, and align the desired number to marker dot ④ on the machine arm.
- 2) The dial calibration is in millimeters.
- 3) When you want to decrease the stitch length, turn stitch length dial ① while pressing feed lever ② in the direction of the arrow.



8. THREAD TENSION (Fig.14)

1. Adjusting the needle thread tension

- 1) Adjust the needle thread tension using tension adjust nut ① according to the sewing specifications.
- 2) As you turn nut ① clockwise (in direction ④), the needle thread tension will increase.
- 3) As you turn nut ① counterclockwise (in direction ③), the tension will decrease.

2. Adjusting the bobbin thread tension

- 1) As you turn tension adjust screw ② clockwise (in direction ⑤), the bobbin thread tension will increase.
- 2) As you turn screw ② counterclockwise (in direction ⑥), the bobbin thread tension will decrease.

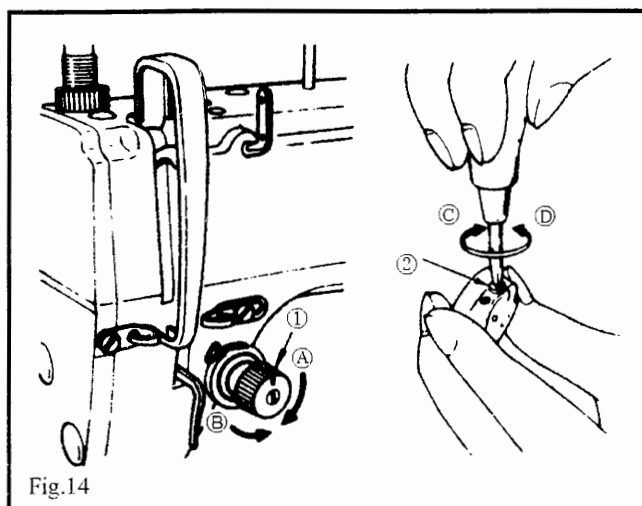

THREAD TAKE-UP SPRING (Fig. 15)

1. Changing the stroke of thread take-up spring ①

- 1) Loosen setscrew ②.
- 2) As you turn tension post ③ clockwise (in direction ④), the stroke of the thread take-up spring will be increased.
- 3) As you turn the knob counterclockwise (in direction ⑤), the stroke will be decreased.

2. Changing the pressure of thread take-up spring ①

- 1) Loosen setscrew ②, and take out tension asm. ⑤.
- 2) Loosen setscrew ④.
- 3) As you turn tension post ③ clockwise (in direction ④), the pressure will be increased.
- 4) As you turn the post counterclockwise (in direction ⑤), the pressure will be decreased.

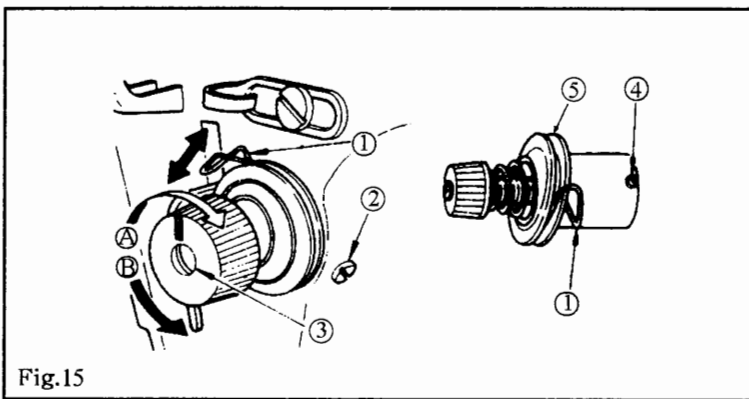

Fig.15

HAND LIFTER (Fig. 16)

- 1) To stop the machine with its presser foot up, turn hand lifter ① in direction ④.
- 2) The presser foot will go up about 5.5mm and stop.
- 3) The presser foot will go back to its original position when hand lifter ① is turned down in direction ⑤.
- 4) Using the knee lifter, you can get the standard presser foot lift of about 10mm and a maximum lift of about 13mm.

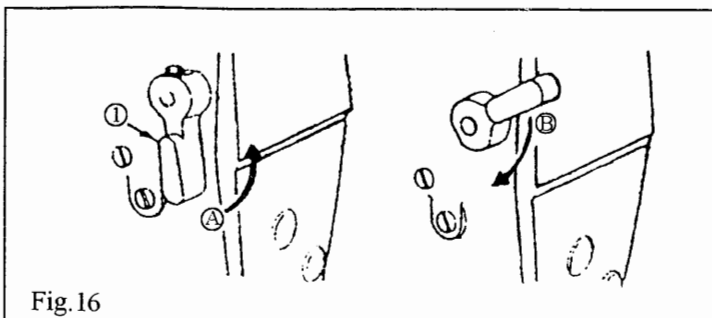

Fig.16

11 PRESSER FOOT PRESSURE (Fig.17)

- 1) Loosen nut ②. As you turn presser spring regulator ① clockwise (in direction A), the presser foot pressure will be increased.
- 2) As you turn the presser spring regulator counterclockwise (in direction B), the pressure will be decreased.
- 3) After adjustment, tighten nut ②.
- 4) For general fabrics, the standard height of the presser spring regulator is 29 to 32 mm (5kg). (For the model 2491D300A it is 7kg)

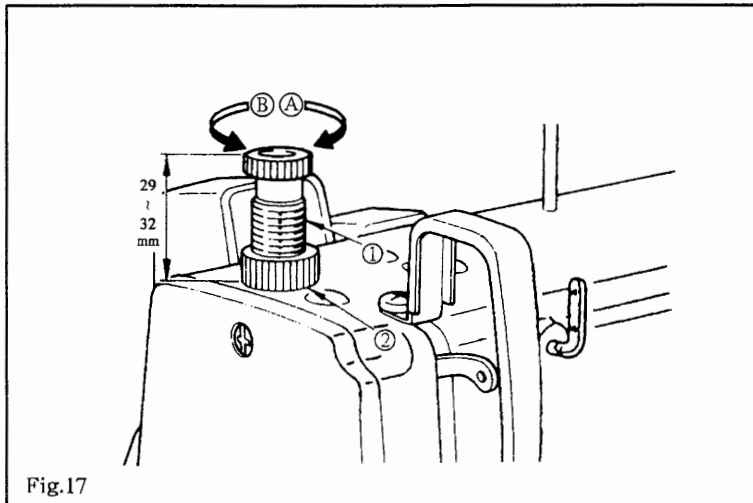

Fig.17

12 ADJUSTING THE FEED TIMING (Fig. 18)

- 1) Loosen two setscrews ② and ③ on feed eccentric cam ①, properly position the eccentric cam. Then retighten the setscrews.
 - 2) To obtain the standard feed timing, when the feed dog is dropping from the throat plate, align the top of the feed dog with the top of the hole on the needle and the top of the throat plate.
 - 3) To advance the feed timing in order to prevent uneven material feed, move the feed eccentric cam in the direction of the arrow.
 - 4) To delay the feed timing in order to increase stitch tightness, move the feed eccentric cam in the opposite direction from the arrow.
- * If moving the feed eccentric cam to far, the needle will be break.

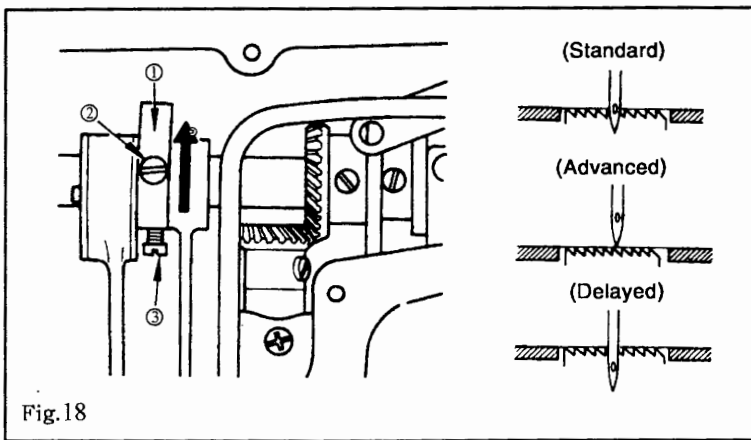

Fig.18

HEIGHT OF THE FEED DOG (Fig. 19)

- 1) The feed dog is factory-adjusted so that it juts out from the throat plate surface 0.75mm to 0.85mm.
For the 2491D300A, 0.95mm to 1.05mm.
- 2) If the feed dog juts out too much, puckering may result when sewing light-weight materials.
(Recommended protrusion: 0.7mm to 0.8mm)
- 3) To adjust the height of the feed dog:
 - (1) Loosen screw ② of crank ①.
 - (2) Move the feed bar up or down to make adjustment.
 - (3) Securely tighten screw ②.

* Precaution

If the screw is tightened too securely, the crank will be abraded.

a Feed dog b Throat plate

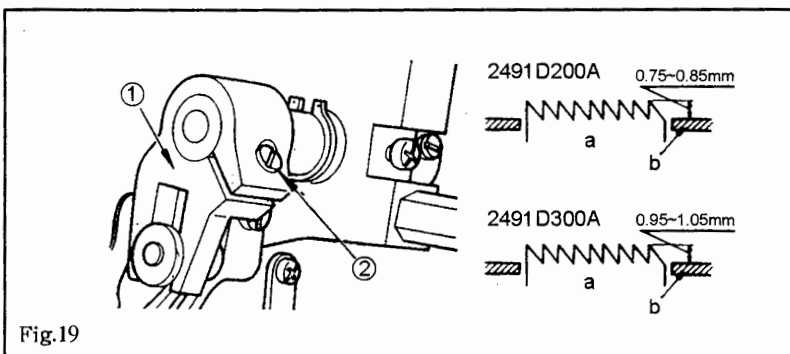

Fig.19

14. NEEDLE-TO-HOOK RELATIONSHIP (Fig.20)

1. Adjust the timing between the needle and the hook as follows:

1) Turn the handwheel to bring the needle bar down to the lowest point of its stroke, and loosen setscrew ①.

* Adjusting the needle bar height

2) Align marker line ① on needle bar ② with the bottom end of needle bar lower bushing ③, then tighten setscrew ①.

* Adjusting position ② of the hook

3) Loosen the two hook setscrews, turn the hand wheel, and align marker line ④ on the needle bar ② with the bottom end of needle bar lower bushing ③.

4) After making the adjustments mentioned in the above steps align hook blade point ⑤ with the center of needle ④. Provide a clearance of 0.04mm to 0.1mm between the needle and the hook, then securely, tighten the hook setscrews.

* Precaution

If the clearance is too small, the tip of the hook will be abraded. If it is too big, it will lead to skip over.

* Note that the type of hook to be substituted for, when replacing the hook, shall be in conformity with the very type of the hook installed in the sewing machine of original assemblage.

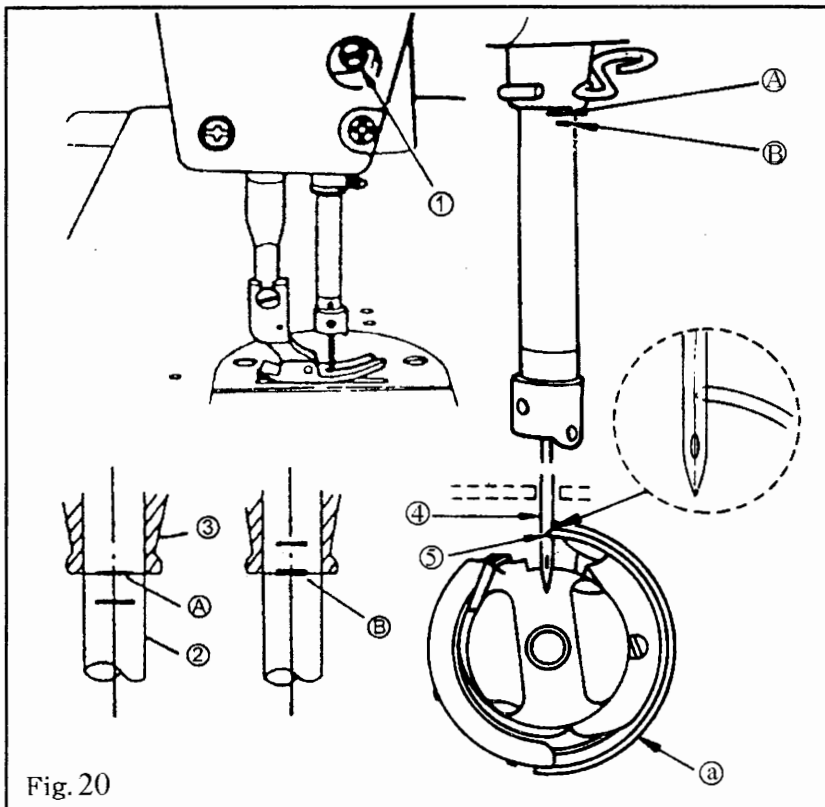
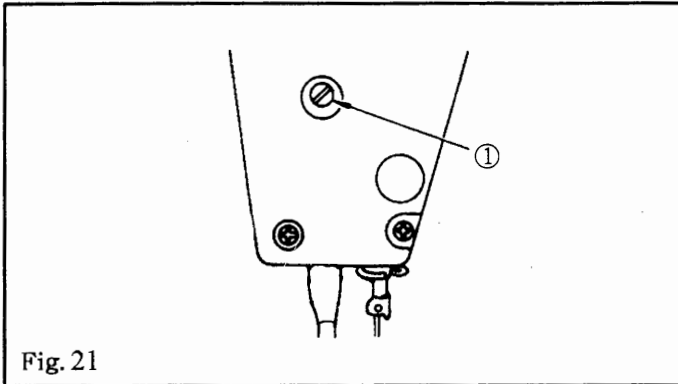

Fig. 20

5. ADJUSTING THE HEIGHT OF THE PRESSER FOOT

- 1) Loosen setscrew ①, and adjust the presser bar height and the angle of the presser foot.
- 2) After adjustment, securely tighten the setscrew.



- 1) When sewing heavy-weight materials, move thread guide ① to the left in direction ① to increase the length of thread pulled out by the thread take-up.
- 2) When sewing light-weight materials, move thread guide ① to the right in direction ② to decrease the length of thread pulled out by the thread take-up.
- 3) When the marker line ③ on the thread guide ① is aligned with the center of the screw, it is standard.

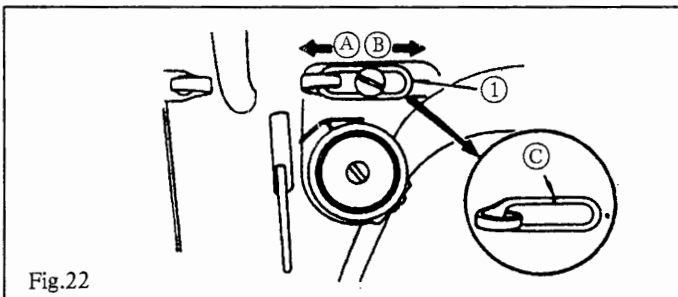

INSTALLING THE BELT COVER AND THE BOBBIN WINDER
(Fig.24, Fig.24, Fig.25)

1. Installing procedure

- 1) Drill four wooden screw guide holes (A), (B), (C) and (D) in the machining table.
- 2) Insert support (1) in the tapped hole in the arm.
- 3) Install the front belt cover (3), get the hand wheel in the middle of the hole.
- 4) Install the back belt cover (2) at (C) and (D).
- 5) Using the screws (4), (5) and washer (6), fix the front belt cover (3) on the support the tightening torque for the screw (4) is about 30 kgfcm, for the screw (5) is about 25 kgfcm.
- 6) Fix the cover (7).
- 7) Move the back belt cover (2) backward until its rubber touches the front belt cover (3), then move further more 0.5 ~ 1mm, fix it using the wooden screws and washers.
- 8) Fix bobbin winder (8) at (A) and (B) using the wooden screws.

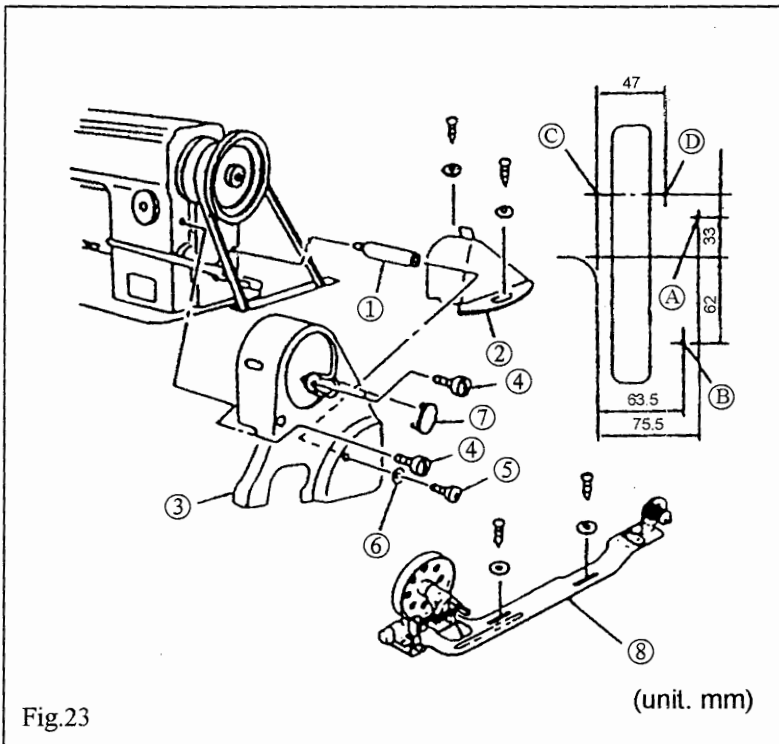

Fig.23

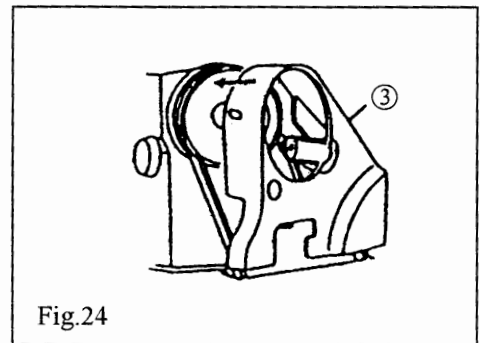

Fig.24

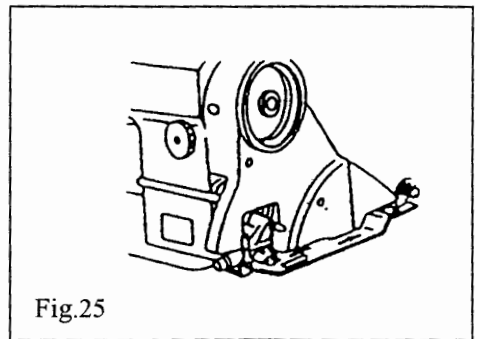
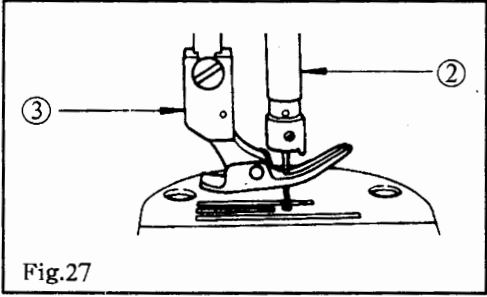
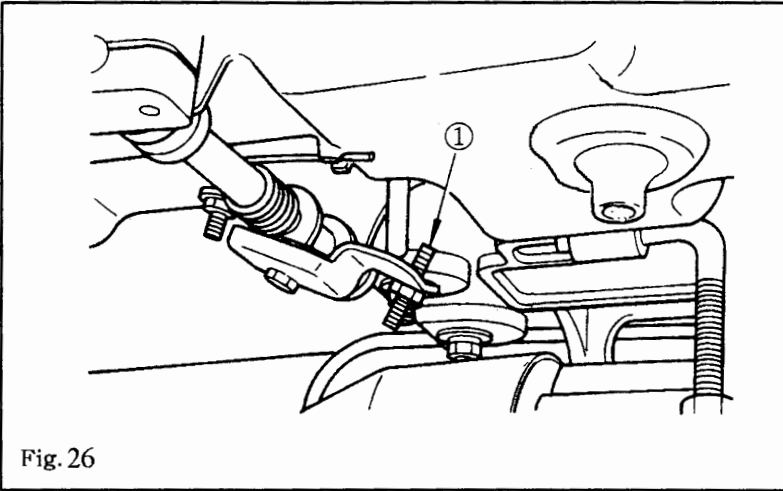

Fig.25

18 ADJUSTING THE HEIGHT OF THE KNEE LIFTER (Fig.26, Fig.27)

- 1) The standard height of the presser foot lifted using the knee lifter is 10mm.
- 2) You can adjust the presser foot lift up to 13mm using knee lifter adjust screw ①.
- 3) When you have adjusted the presser foot lift to over 10mm, be sure that the bottom end of needle bar ② in its lowest position does not hit presser foot ③.



9 SPECIFICATIONS

	Model 2491D200A	Model 2491D300A
Application	For medium-weight materials	For heavy-weight materials
Sewing speed	Max. 4,600 s.p.m.	Max. 4,200 s.p.m.
Stitch length	Max. 5mm	Max. 5mm
Presser foot lift (by knee lifter)	10mm (standard) 13mm (max.)	10mm (standard) 13mm (max.)
Needle	1955-01 (DP × 5)#14	1955-01 (DP × 5)#18
Lubricating oil	SINGER "C" oil	

ILLUSTRATED PARTS LIST

Model 2491D200A (For Medium Weight Materials)

1. Arm bed components

Ref.No.	Part No.	Description	Amt.
1	GS0548	Bed screw stud	4
2	SY0095	Side plate	1
3	GR3340	Gasket	1
4	GS053	Screw 3/16-28 L=9	8
5	SY0094	Face plate arm	1
7	GR3343	Gasket	1
8	GS053	Screw 3/16-28 L=9	3
9	GR1458(B)	Rubber plug	2
10	GR1463(B)	Rubber plug	1
11	GR3344(B)	Rubber plug	2
12	GR3345(B)	Rubber plug	1
13	GR1464(B)	Rubber plug	1
14	GR4021	Scale base plate	1
15	GS086	Screw	2

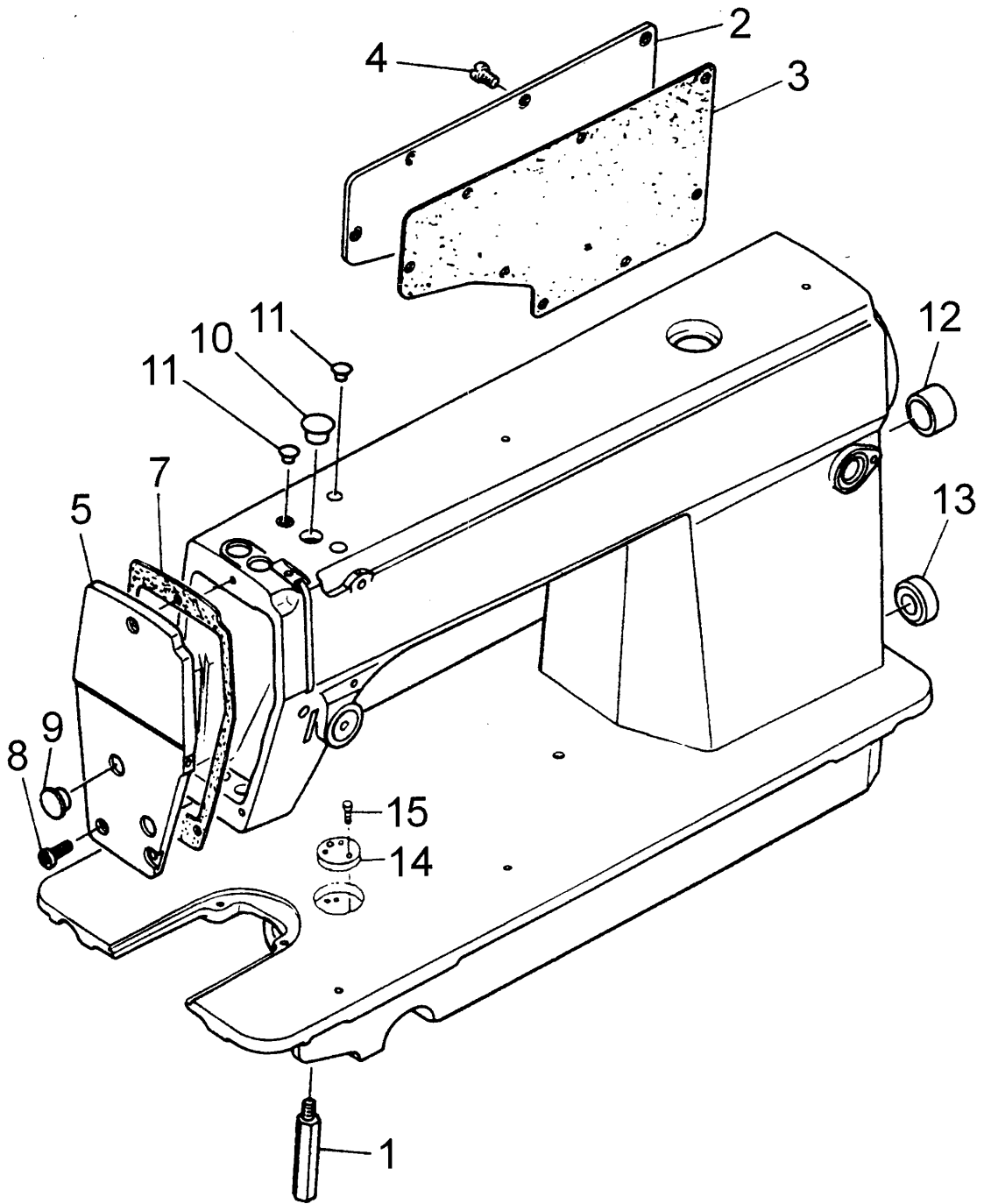

2.Main shaft & thread take-up components

Ref.No.	Part No.	Description	Amt.
1	GP166(B)	Hand wheel	1
2	GS03	Screw 15/64-28 L=15	2
3	GZ431	Main shaft	1
4	GR3346	Oil seal	1
5	GO462	Main shaft bushing, rear	1
6	GR1469	Thrust collar asm.	1
7	GS39	Screw 1/4-40 L=6	2
8	GO463	Bushing, intermediate	1
9	GS0549	Screw	1
10	GO464	Main shaft bushing, front	1
11	GR1470	Robber felt	1
12	GX334	Oil amount adjusting pin asm.	1
13	GO269	Rubber pushing	1
14	GR1471	Rubber ring	1
15	GH561	Counterweight	1
16	GS06	Screw 1/4-40 L=6	1
17	GR1472	Rubber ring	1
18	GS0550	Screw 9/32-28 L=16	1
19	GR1473	Counterweight protecting plate	1
20	GH402/2	Needle bar crank asm.	1
21	GS39	Screw 1/4-40 L=6	2
22	GH564/4	Thread take-up lever asm.	1
23	GR3349	Rubber	1
24	GO270	Needle bearing	1
25	GX566	Thread take-up crank shaft	1
26	GR3350	Oiling wick	1
27	GS04	Screw 15/64-28 L=10.5	1
28	GS09	Screw (left twist) 9/64-40 L=4.8	1
29	GK240(B)	Thread take-up lever cover	1
30	GSO551	Screw 3/16-28 L=6	1

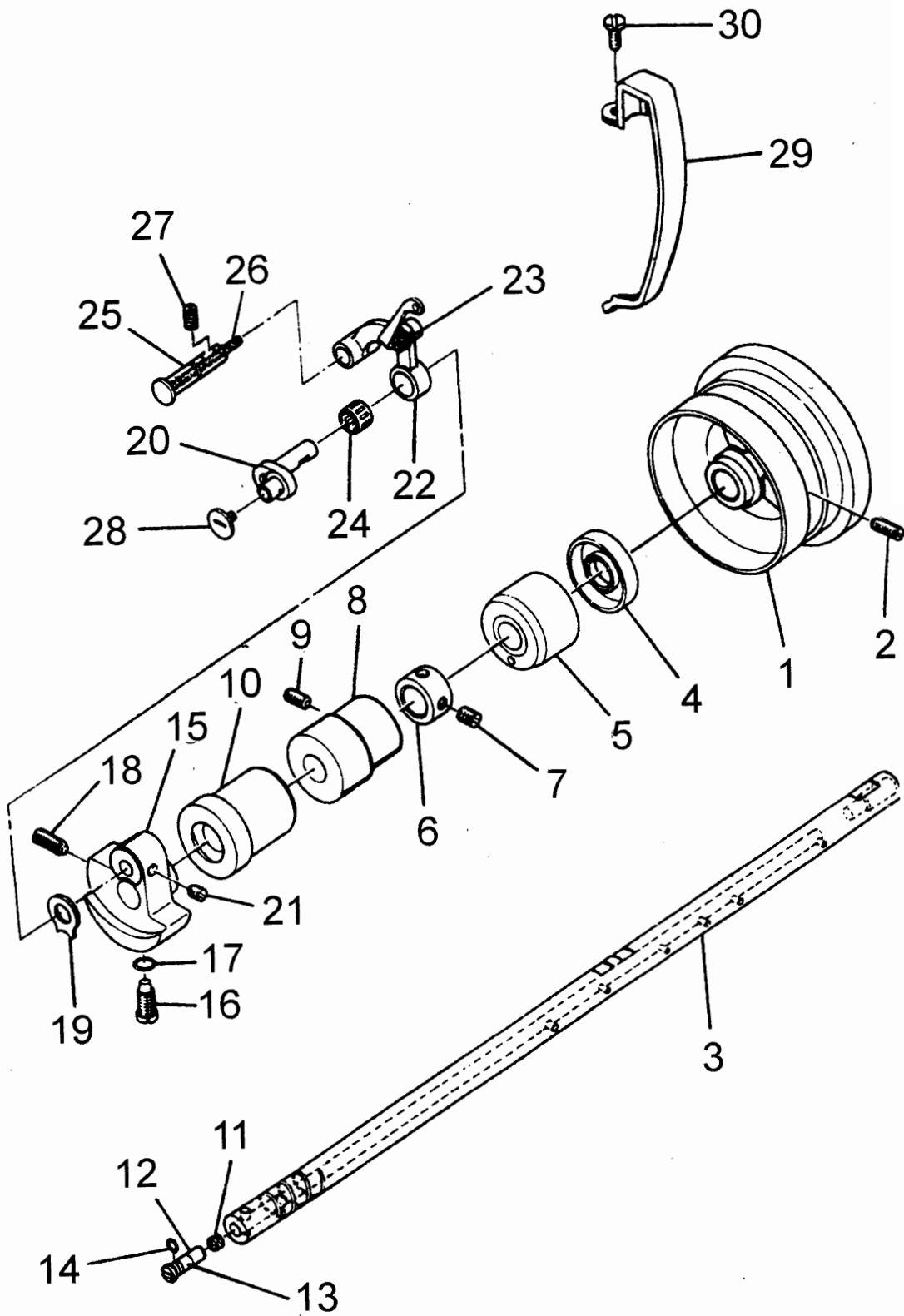

3. Needle bar & thread tension components

Ref.No.	Part No.	Description	Amt.
1	GH334	Needle bar crank rod	1
2	GO270	Needle bearing	1
3	GR1478	Needle bar connection asm.	1
4	GS011	Screw 9/64-40 L=6	1
5	GU168	Slide block	1
6	GO271	Needle bar bushing , upper	1
7	GR1479	Cap	1
8	GO272	Needle bar bushing, lower	1
9	GR3351	Needle bar thread guide	1
10	GZ1102	Needle bar	1
11	GR3352	Needle bar thread guide	1
12	GS071	Screw 1/8-44 L=4.5	1
13	N1955-01(#14)	Needle #14	1
14	GR3353	Two-hole thread eyelet	1
15	GS0551	Screw 3/16-28 L=6	1
16	GR3354	Frame thread guide, right	1
17	GS0552	Screw 11/64-40 L=6	1
18	GR3355	Frame thread guide , left	1
19	GS0551	Screw 11/64-40 L=6	1
20	GR1487	Tension post socket	1
21	GW250	Take-up spring	1
22	GS015	Screw	1
23	GS016	Set screw 9/64-40 L=5.5	1
24	GX567	Thread release pin	1
25	GR1488	Tension disc	2
26	GR1489	Tension disc holder	1
27	GW251	Tension spring	1
28	GR1490	Tension disc stopper	1
29	GL0113(B)	Tension nut	1
30	GS48	Screw 15/64-28 L=7	1
31	GX568	Tension release supporting pin	1
32	GR1717	Snap ring	1
33	GR3357	Washer plate	1
34	GW432	Tension release pin spring	1
35	GR1491/5	Needle thread guide pin asm.	1
36	GR1492	Needle thread guide pin	(1)
37	GR1493	Tension disc	(2)
38	GW252	Tension spring	(1)
39	GS017	Hinge screw	(1)

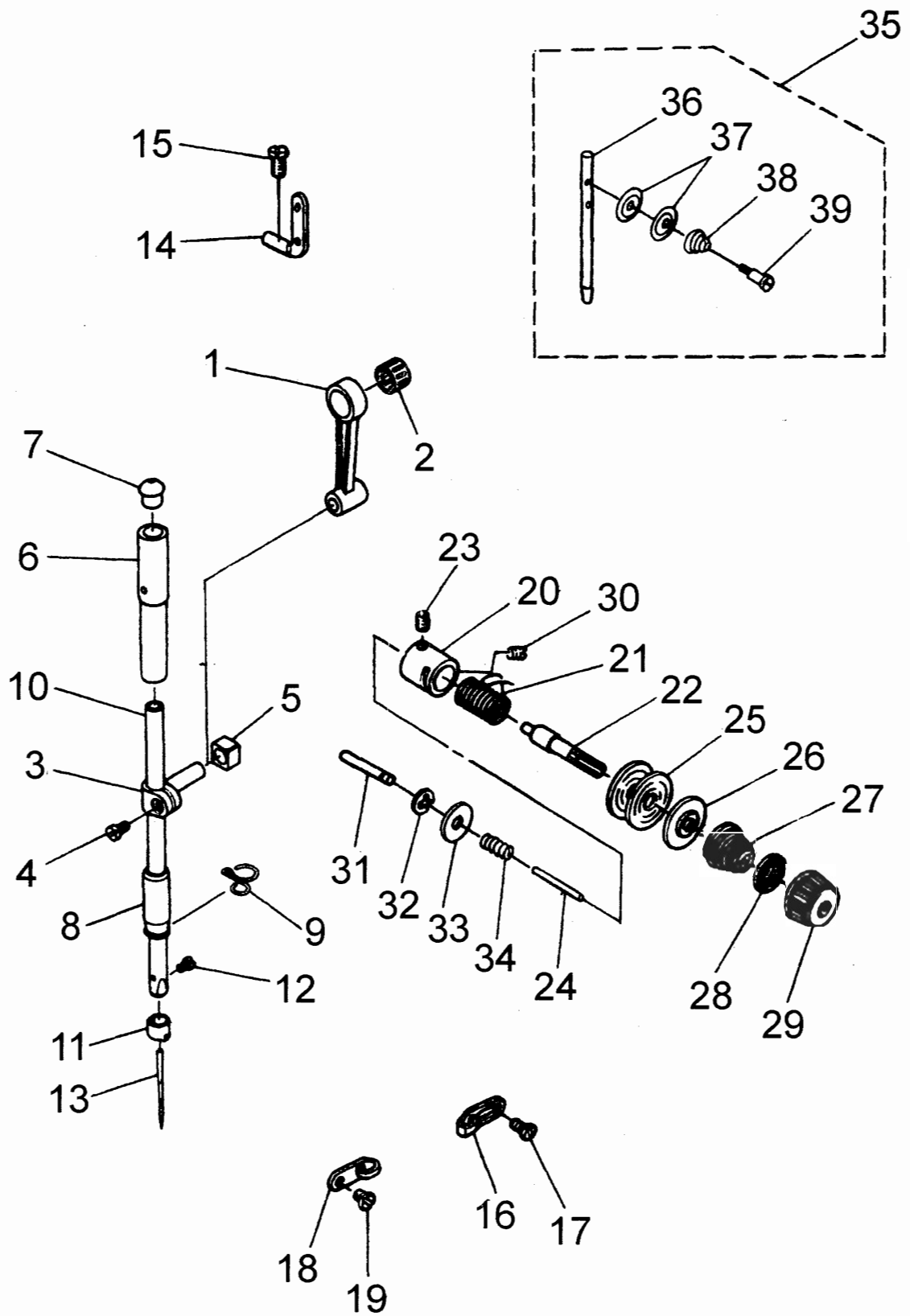

4.Presser bar components

Ref.No.	Part No.	Description	Amt.
1	GS0553(B)	Presser spring regulator	1
2	GL0114(B)	Nut	1
3	GR1494	Presser guide bar	1
4	GW253	Presser spring	1
5	GZ275	Presser bar	1
6	GR3358	Presser bar guide bracket	1
7	GS033	Screw 1/4-40 L=8	1
8	GR3359	Presser bar thread guide	1
9	GS0100	Screw 9/64-40 L=8.5	2
10	GO273	Presser bar bushing , lower	1
11	GM386/4	Presser foot asm.	1
12	GS020	Screw 9/64-40 L=10.5	1
13	GR3360(B)	Hand lifter	1
14	GS0554	Screw	1
15	GR3361/2	Hand lifter cam asm.	1
16	GR1503	Rubber ring	1
17	GR3363	Lifting lever	1
18	GR3364/3	Hand lifter link asm.	1
19	GS0555	Link shaft	2
20	GR1510	Snap ring	3
21	GR3366	Lifting lever ring	1
22	GR3367	Tension release plate	1
23	GS0556	Tension release shaft	1
24	GR1510	Snap ring	2
25	GW433	Tension release return spring	1
26	GR3368	Lifting lever connecting rod	1
27	GR1510	Snap ring	1
28	GR3369	Lifting lever link	1
29	GS0557	Hinge screw	1
30	GS0558	Hinge screw	1
31	GR3370	Connecting rod vertical	1
32	GR4011	Needle safety guide	1

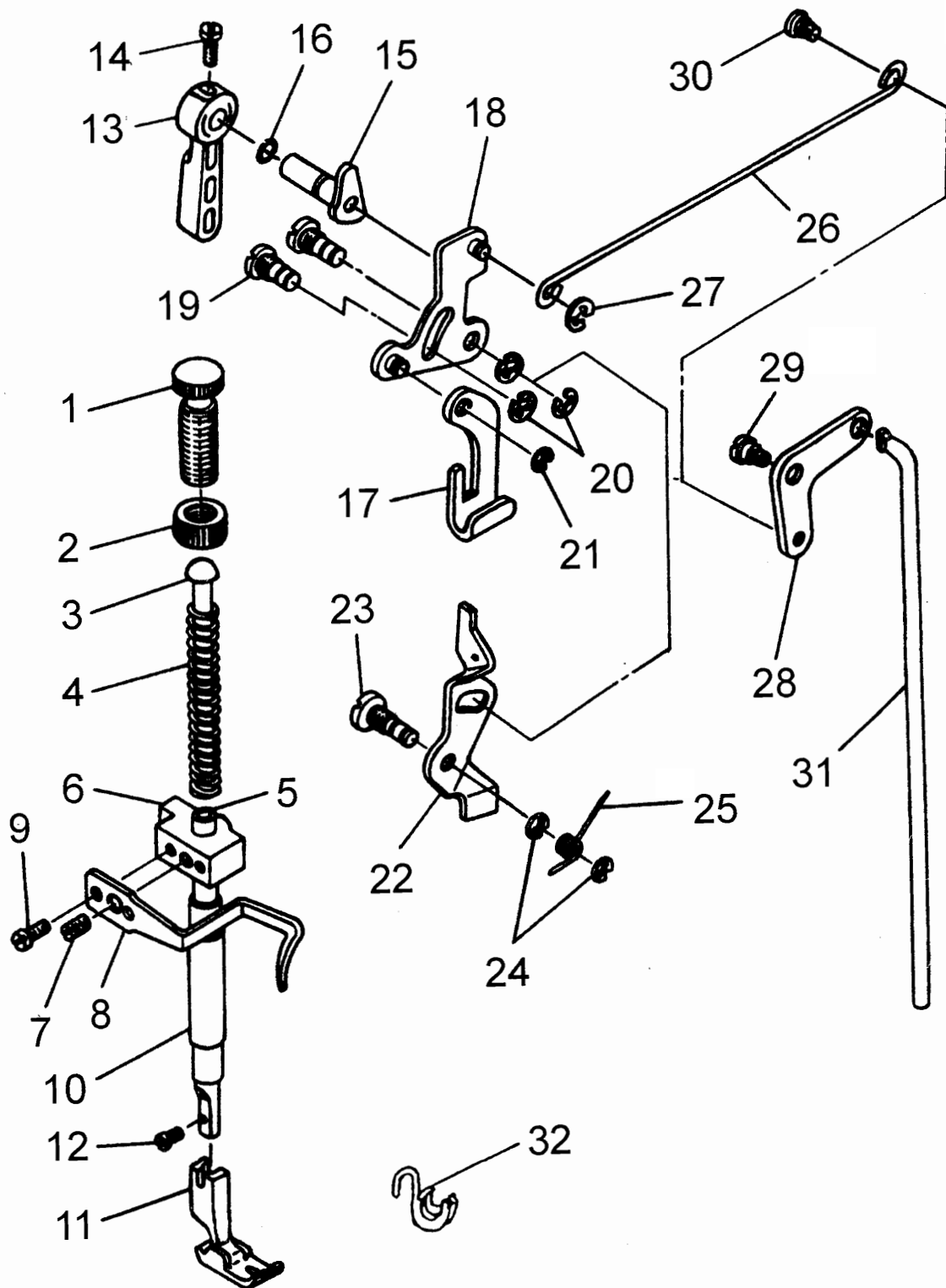

5.Hook driving shaft components

Ref.No.	Part No.	Description	Amt.
1	GN161	Hook asm.	1
2	GN162	Bobbin case asm.	1
3	GN163	Bobbin	1
4	GS029	Screw	2
5	GR3371	Positioning finger	1
6	GS030	Screw 11/64-40 L=9.5	1
7	GZ434	Hook driving shaft	1
8	GS031	Oil seal screw	1
9	GR1515	Oil wick	1
10	GR3372	Thrust collar	1
11	GS032	Screw 11/64-40 L=3.5	2
12	GO331/3	Bushing asm. front	1
13	GS0559	Screw	1
14	GO470	Bushing , rear	1
15	GS053	Screw 3/16-28 L=9	1
16	GR1519	Thrust collar asm.	1
17	GS082	Screw 11/64-40 L=4.8	2
18	GC165	Pinion asm.	1
19	GS033	Screw 1/4-40 L=8	8
20	GC166	Gear asm. large	1
21	GO471	Bushing , lower	1
22	GO472	Bushing , upper	1
23	GS053	Screw 3/16-28 L=9	1
24	GZ435	Upright shaft	1
25	GC167	Pinion asm.	1
26	GC168	Gear asm.	1

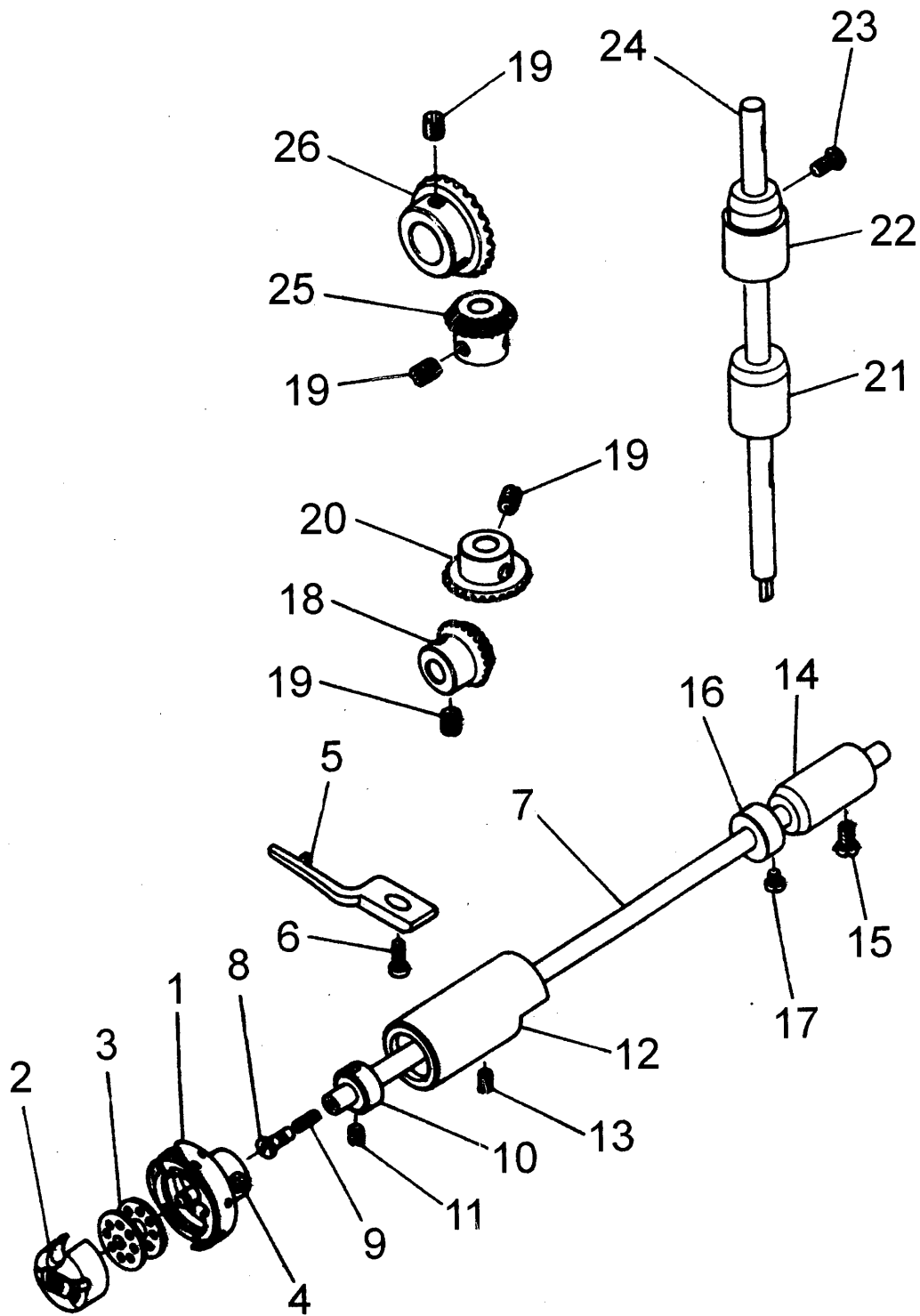

6.Feed mechanism components

Ref.No.	Part No.	Description	Amt.
1		Feed drive eccentric cam asm.	1
2	GT198	Feed drive eccentric cam	(1)
3	GS034	Screw 1/4-40 L=11	(2)
4	GR3373	Thrust collar	(1)
5	GS011	Screw 9/64 L=6	(2)
6	GH568	Rocker shaft connecting rod	1
7	GX570	Walking foot pin	1
8	GS0560	Screw 9/64-40 L=6	1
9	GR3374	Walking foot link	2
10	GR3375	Connecting link	2
11	GX571	Walking foot pin	2
12	GS0560	Screw 9/64-40 L=6	2
13	GR3376/2	Walking foot adjusting link	1
14	GX573	Adjusting link fulcrum shaft	1
15	GS48	Screw 15/64-28 L=7	1
16	GX573	Adjusting link fulcrum shaft	1
17	GS48	Screw 15/64-28 L=7	1
18	GH569	Feed rocker shaft crank asm.	1
19	GX574	Walking foot pin	1
20	GS0560	Screw 9/64-40 L=6	1
21	GS0561	Screw 3/16-28 L=14	1
22	GZ436	Feed rocker shaft	1
23	GR1524	Retaining ring	1
24	GR1469	Thrust collar asm.	1
25	GS39	Screw 1/4-40 L=6	2
26	GO473	Feed rocker shaft bushing	1
27	GR3378	Oil wick	1
28	GR3379	Feed rocker asm.	1
29	GS69	Screw 3/16-28 L=14	1
30	GR1528	Washer	1
31	GR3380/5	Feed bar asm	1
32	GX575	Feed bar shaft	1
33	GS092	Screw 11/64-40 L=7	1
34	GM206	Feed dog	1
35	GS072	Screw 1/8-44 L=6	2
36	GM207	Throat plate	1
37	GS044	Screw 11/64-40 L=8.5	2
38	GM340/4	Bed slide asm.	1
39	GM204	Slide plate	(1)
40	GW434	Bed slide spring	(1)
41	GS045	Screw 3/32-56 L=1.9	(2)
42	GH570	Driving shaft crank asm. front	1
43	GS037	Screw 11/64-40 L=10.5	1
44	GZ437	Feed driving shaft	1
45	GR1524	Retaining ring	1
46	GO336	Feed rocker shaft bushing	1
47	GH571	Rear crank asm.	1
48	GS0561	Screw 3/16-28 L=12	1
49	GH572	Connecting rod	1
50	GS0562	Hinge screw	1
51	GL7	Nut 9/32-28	1
52	GR1535	Snap ring	1
53	GR1469	Thrust collar asm.	1
54	GS39	Screw 1/4-40 L=6	2

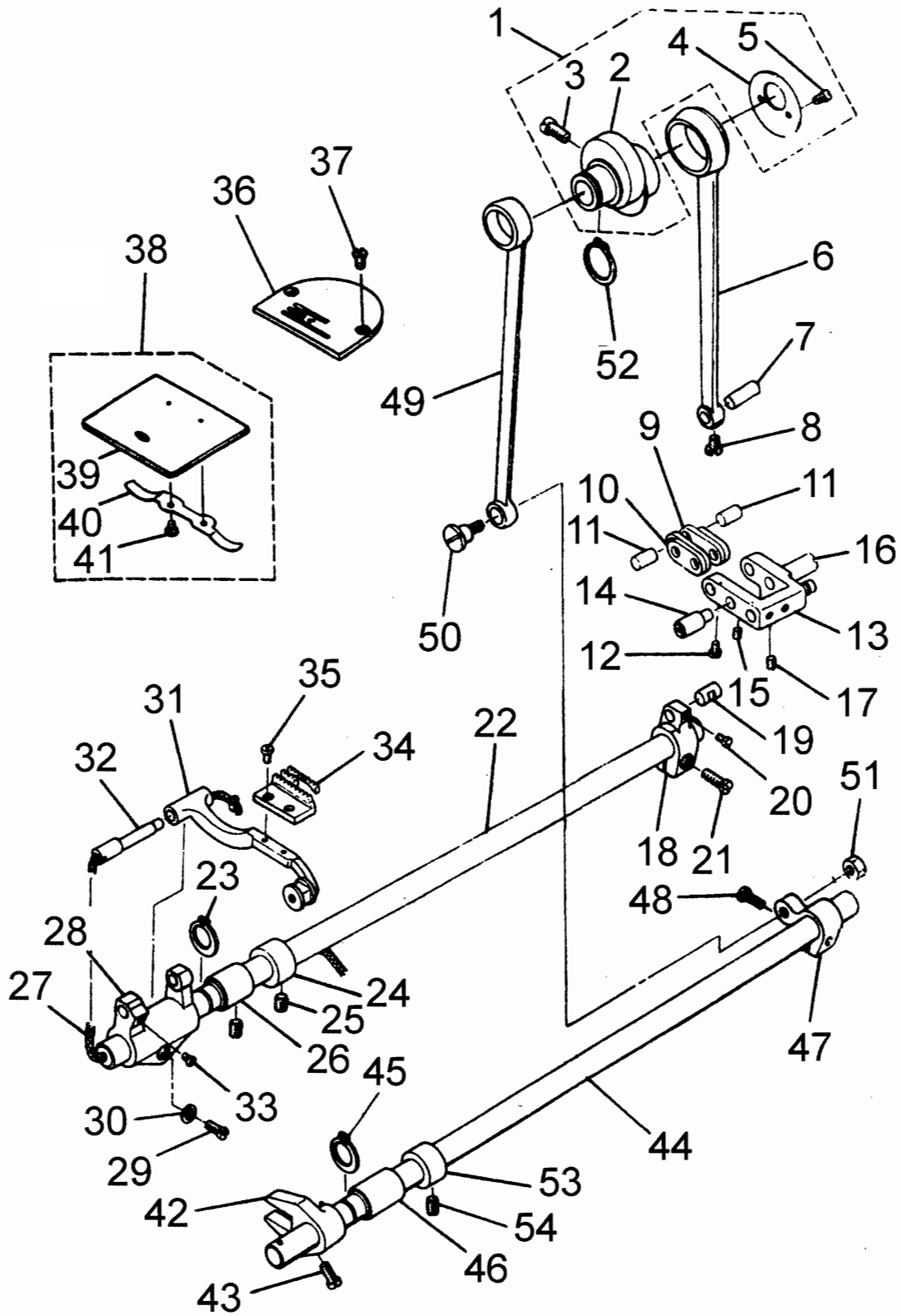

7.Feed regulating components

Ref.No.	Part No.	Description	Amt.
1	GR3382(B)	Feed dial	1
2	GS0563	Screw	1
3	GS0564	Feed regulator screw	1
4	GR3383	Rubber ring	1
5	GX576	Pin	1
6	GW257	Spring	1
7	GR3384	Feed regulator	1
8	GO474	Feed regulator bushing	1
9	GS0565	Screw	1
10	GX577	Feed regulator pin	1
11	GS011	Screw 9/64-40 L=6	2
12	GH573	Feed regulator connecting rod	1
13	GR1510	Snap ring	2
14	GZ438	Feed reverse shaft	1
15	GR3385	Rubber ring	1
16	GO475	Feed lever metal	1
17	GR3386(B)	Reverse feed control lever	1
18	GS050	Screw 1/4-40 L=10	1
19	GS033	Screw 1/4-40 L=8	1
20	GH574/2	Feed reverse arm asm.	1
21	GS0566	Feed reverse arm screw	1
22	GW435	Feed reverse spring	1
23	GR3387	Feed spring hook	1
24	GR3388	Adjusting link spring guide	1
25	GS0567	Screw 11/64-40 L=5	2
26	GW436	Adjusting link spring	1

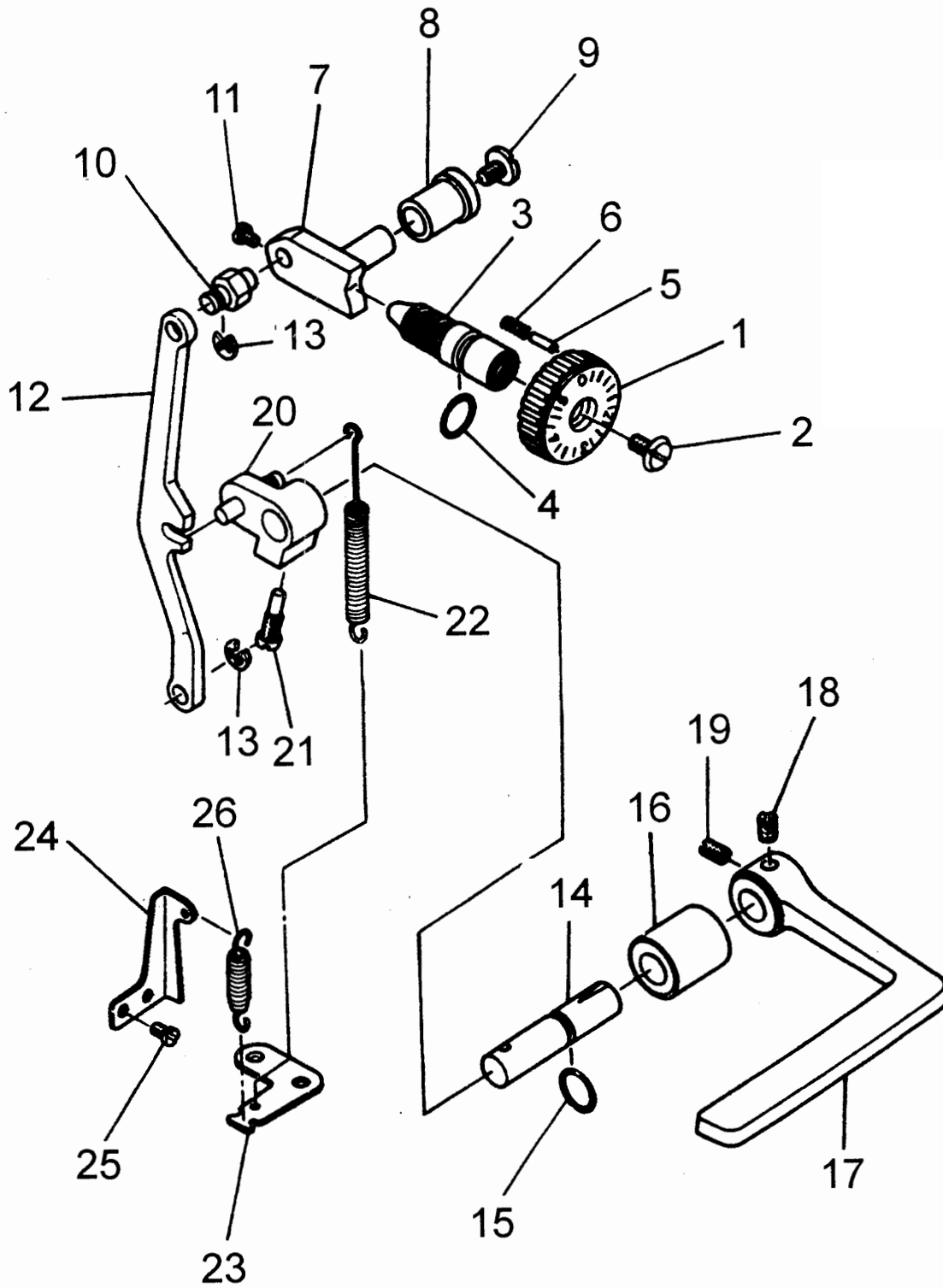

8.Lubrication components

Ref.No.	Part No.	Description	Amt.
1	GR3389/12	Lubricating oil pump asm.	1
2	GR3390	Oil pump installing base	(1)
3	GS062	Screw 15/64-28 L=9	1
4	GR3391	Oil pump	(1)
5	GO476	Oil pump bushing	(1)
6	GR3392	Oil pump impeller	(1)
7	GR3393	Oil pump impeller cover	(1)
8	GR3394	Lubricating oil pump cover	(1)
9	GS554	Screw	(3)
10	GR3395	Hook driving shaft oil tube	(1)
11	GR3396	Plunger	(1)
12	GW437	Plunger spring	(1)
13	GS0569	Plunger screw	(1)
14	GS0568	Screw	(3)
15	GS0570	Oil pump support	1
16	GS030	Screw 11/64-40 L=9.5	1
17	GR3397	Rubber joint	1
18	GR3398	Main shaft oil tube	1
19	GR3399	Oil tube	1
20	GS054	Oil adjusting screw	1
21	GW259	Spring	1
22	GR3400	Tube holder (lower)	1
23	GS062	Screw 15/64-28 L=9	1
24	GR1561	Oil sight window	1
25	GR1562	Rubber ring	1
26	GR3401	Oil return tube	1
27	GR1566	Oil return tube holder	1
28	GS0551	Screw 3/16-28 L=6	1
29	GR1567	Anti-dust oil felt	1
30	GR1568	Oil felt	1
31	GR1569	Oil felt presser	1
32	GR3403	Arm oil shield	1
33	GR3404	Oil wick	1
34	GS44	Screw 1/8-44 L=4	1

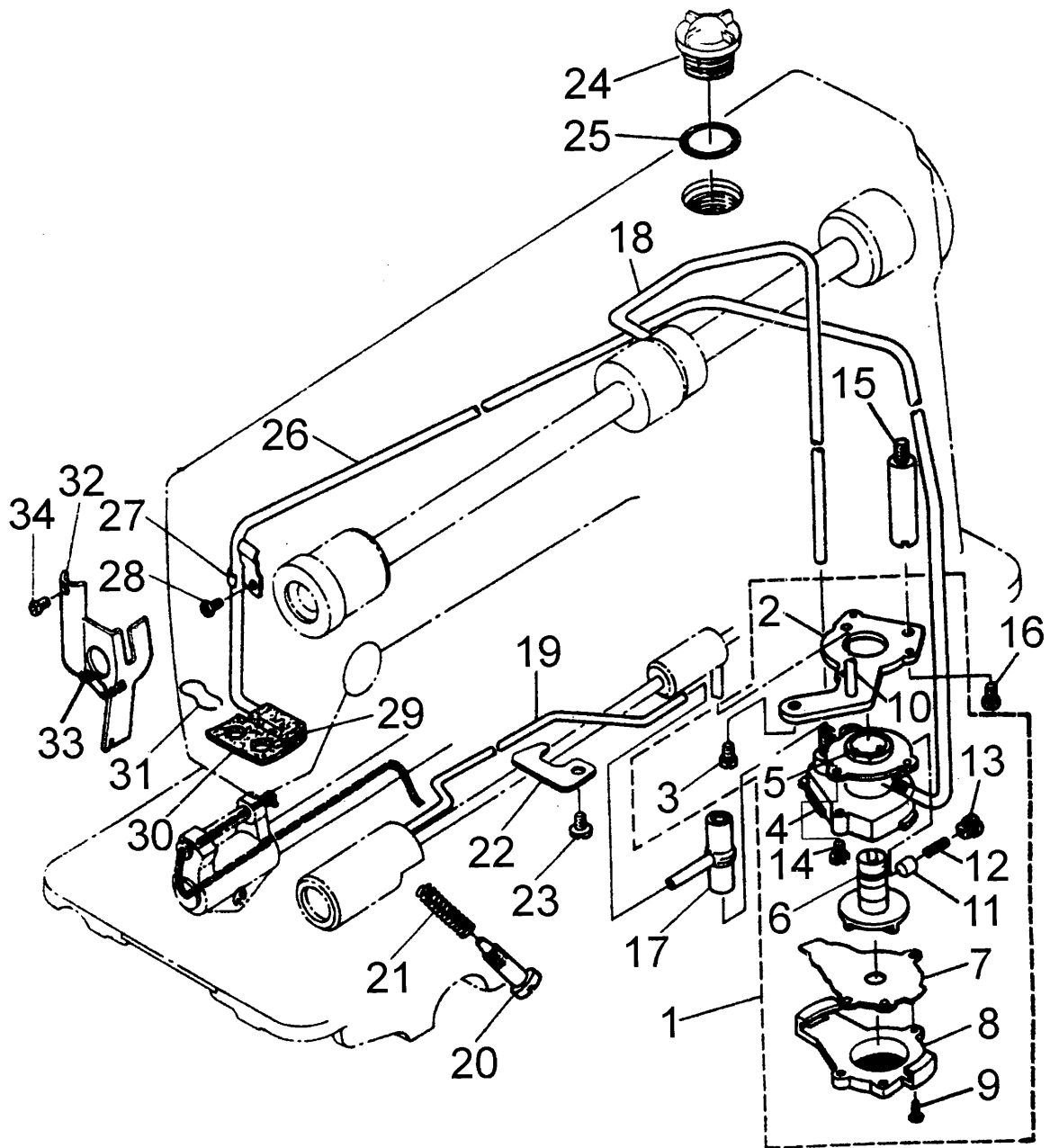

9.Oil reservoir & knee lifter components

Ref.No.	Part No.	Description	Amt.
1	GR3405/17	Oil reservoir asm.	1
2	GR3406	Oil reservoir	(1)
3	GR3407	Gasket	(1)
4	GR3408	Rubber cushion	(4)
5	GS0571	Screw	(1)
6	GR3409	Rubber ring	(1)
7	GR1576	Oil reservoir magnet	1
8	GR1578	Oil reservoir felt cushion	2
9	GR1579(B)	Oil reservoir rubber cushion	2
10	GBX108	Nail	4
11	GH579	Knee press lifte rod	1
12	GH576	Connecting rod, vertical	1
13	GS0572	Screw	1
14	GS057	Screw 15/64-28 L=30	2
15	GL21	Nut 15/64-28	2
16	GW438	Spring	1
17	GZ439	Knee press rod	1
18	GR1583	Snap ring	1
19	GR3410	Bearing bracket	1
20	GS0573	Screw 9/32-20 L=20	2
21	GR3411/6	Knee press plate asm.	1
22	GR1586	Knee lifter plate rod	1
23	GR3412	Knee press plate	1
24	GKR13	Knee press plate cover	1
25	GR3413	Rubber	1
26	GR3414	Knee press plate holder	1
27	GS584	Screw 15/64-28 L=15	1
28	GW262	Knee press plate spring	1
29	GW02	Screw	1
30	GR1575	Rubber ring	1

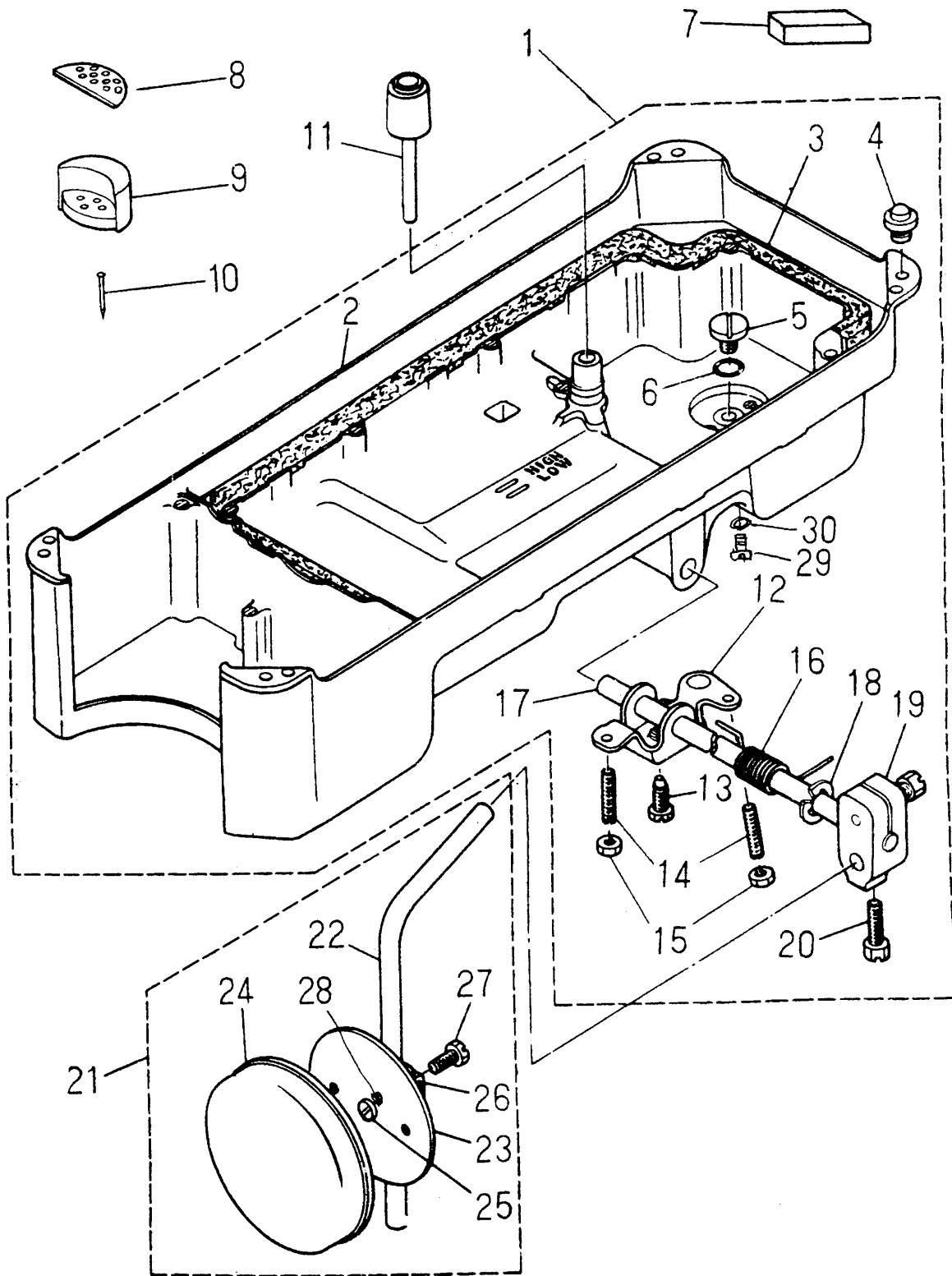

10. Machine head accessories(1)

Ref.No.	Part No.	Description	Amt.
1	GR1590/2	Machine hinge plate asm.	2
2	GR1593(B)	Machine hinge plate	2
3	GBX105	Nail	4
4	GK241(B)	Beltcover, A	1
5	GR3415(B)	Beltcover, A cap	1
6	GK242/3(B)	Beltcover, B asm.	1
7	GK243(B)	Beltcover, B	1
8	GK244/2(B)	Beltcover, B cover asm.	1
9	GBS120	Wood screw D=4.5 L=20	2
10	GBR147	Washer	2
11	GS0574	Beltcover, A screw	2
12	GS0575	Beltcover support	1
13	GS0576	Screw 3/16-28 L=14	1
14	GR3417	Washer	1
15	N1955-01(#14)	Needle	1 pack
16	GR1601	Screw driver, large	1
17	GR1602	Screw driver, medium	1
18	GR1603	Screw driver, small	1
19	GN163	Bobbin	3
20	GF424	Machine head cover	1
21	GBR148	Machine rest pin	1
22	GR1604/3	Oil reservoir asm.	1

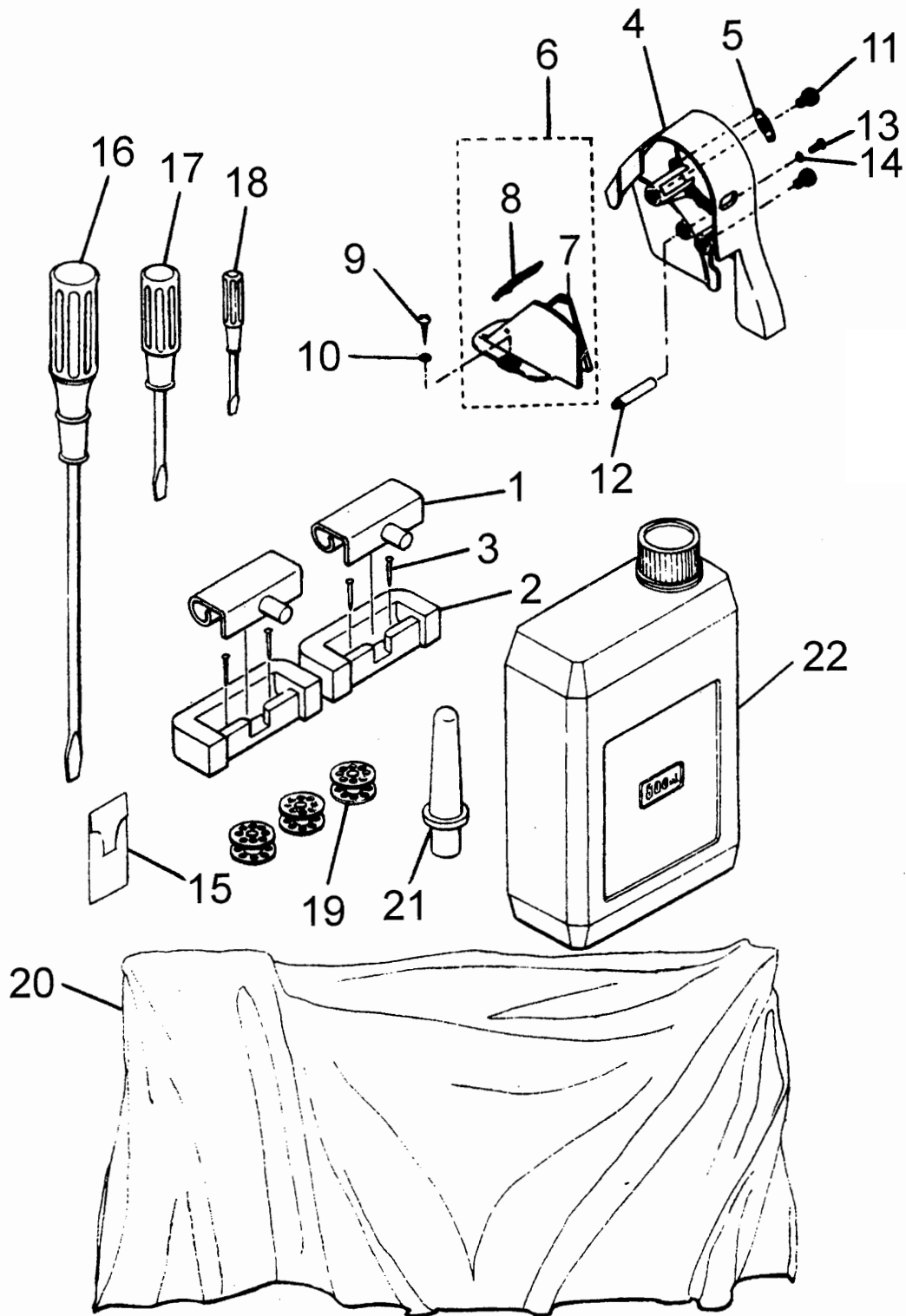

Machine head accessories(2)

Ref.No.	Part No.	Description	Amt.
1	GR3419	Bobbin winder base asm.	1
2	GR3420	Thread winder base asm.	1
3	GP167	Thread winder asm.	1
4	GS013	Screw	1
5	GZ284	Bobbin winder shaft	1
6	GR3421	Connecting rod	1
7	GX347	Connecting rod pin	1
8	GR3422	Bobbin winder frame rod	1
9	GX347	Bobbin winder frame rod pin	1
10	GS063	Screw 1/8-44 L=12.5	1
11	GX348	Bobbin winder frame pin	1
12	GW263	Bobbin winder frame spring	1
13	GR1613	Rubber brake	1
14	GR3423	Presser plate	1
15	GS064	Screw 11/64-40 L=3	1
16	GW439	Bobbin winder spring	1
17	GS065	Hinge screw	1
18	GR3425	Thread tension bracket asm.	1
19	GS0577	Screw	1
20	GR1617	Bobbin winder tension disc collar	1
21	GR1488	Tension disc	2
22	GW256	Tension spring	1
23	GL22	Thread tension stud nut	1
24	GS0578	Screw 11/64-40 L=7.8	1
25	GBS120	Wood screw	2
26	GBR147	Washer	2
27	GR1744	Spool rest rod rubber cap	1
28	GZ1039	Spool rest rod (lower)	1
29	GZ1040	Spool rest rod (upper)	1
30	GR5224	Spool rested joint	1
31	GR5225	Thread guide asm.	2
32	GR5226	Thread guide arm joint	2
33	GS558	Screw	2
34	GR1748	Thread guide ring	2
35	GS067	Spool pin	2
36	GR1625	Spring washer	2
37	GR1626	Washer	2
38	GL23	Nut	2
39	GR4015	Spool rest	2
40	GR4014	Spool vibration stopper	2
41	GR1696	Washer	2
42	GR1751	Spring washer	1
43	GL158	Nut	2
44	GR1753	Rubber washer	2
45	GR4013	Spool vibration stopper	2

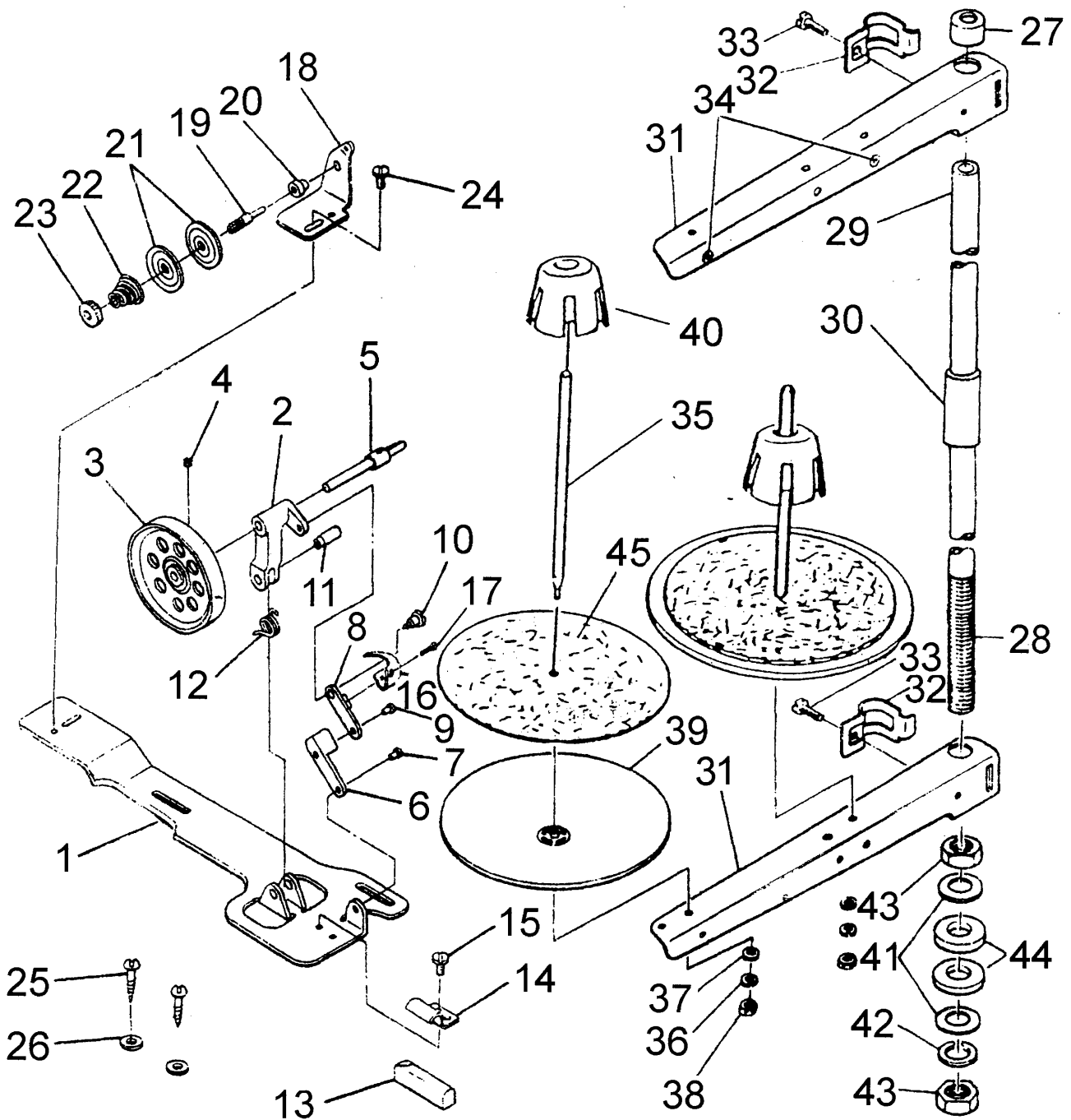

11. Machine stand, table & electric appliance components*

Ref.No.	Part No.	Description	Amt.
1	GKR302/5	Stand side asm. left	1
2	GKR305/5	Stand side asm. right	1
3	GKR318	Rubber cushion	4
4	GKL104	Nut	4
5	GKR196/2	Screw	4
6	GKR198	Space ring	4
7	GKR309	Stand side support	1
8	GKS110	Screw	4
9	GKR106	Spring washer	4
10	GKR122	Washer	8
11	GKL101	Nut	4
12	GKR310	Treadle brace	1
13	GKS110	Screw	2
14	GKR106	Spring washer	2
15	GKR122	Washer	2
16	GKR311	Treadle brace locknut plate	2
17	GKX301	Treadle shaft	1
18	GKR317	Treadle bracket	2
19	GKS110	Screw	2
20	GKR122	Washer	4
21	GKR106	Spring washer	2
22	GKL101	Nut	2
23	GKR312	Treadle	1
24	GKR313	Gas Ket	1
25	GKR314	Collar	2
26	GKR315	Treadle pitman	1
27	GKS102	Screw	2
28	GKR112	Washer	4
29	GKL102	Nut	2
30	GKR116	Pitman rod, lower	1
31	GKW301	Spring	1
32	GKR118	Pitman rod, upper	1
33	GKR183	Joint	1
34	GKS110	Joint screw	1
35	GKL101	Joint nut	1
36	GKX101	Pitman rod split pin (upper)	1
37	GBS114	Table wood screw	4
38	GKR112	Table wood screw washer	4
39	GKR186	Table washer	4
40	GBR150	Table	1
41	GBR151	Drawer	1
42	GBR152	Drawer rail	2
43	GBS121	Drawer rail wood screw	6
44	GD234	Model GFC4024 motor	1
45	GD219	Motor wire	1
46	GD108	Motor wire	1
** 47	GD233	Motor pulley	1
48	GE122	Machine driving belt	1
49	GKS122	Motor & table connecting screw	3
50	GKR209	Motor & table connecting washer	3
51	GKR106	Motor & table connecting spring washer	3
52	GKL101	Motor & table connecting nut	3
53	GD227	Power source switch	1
54	GBS104	Power source switch wood screw	2

* Note that parts above mentioned shall be purchased in separate order.

** Part No. GD233 Motor pulley is used for Model 2491D300A

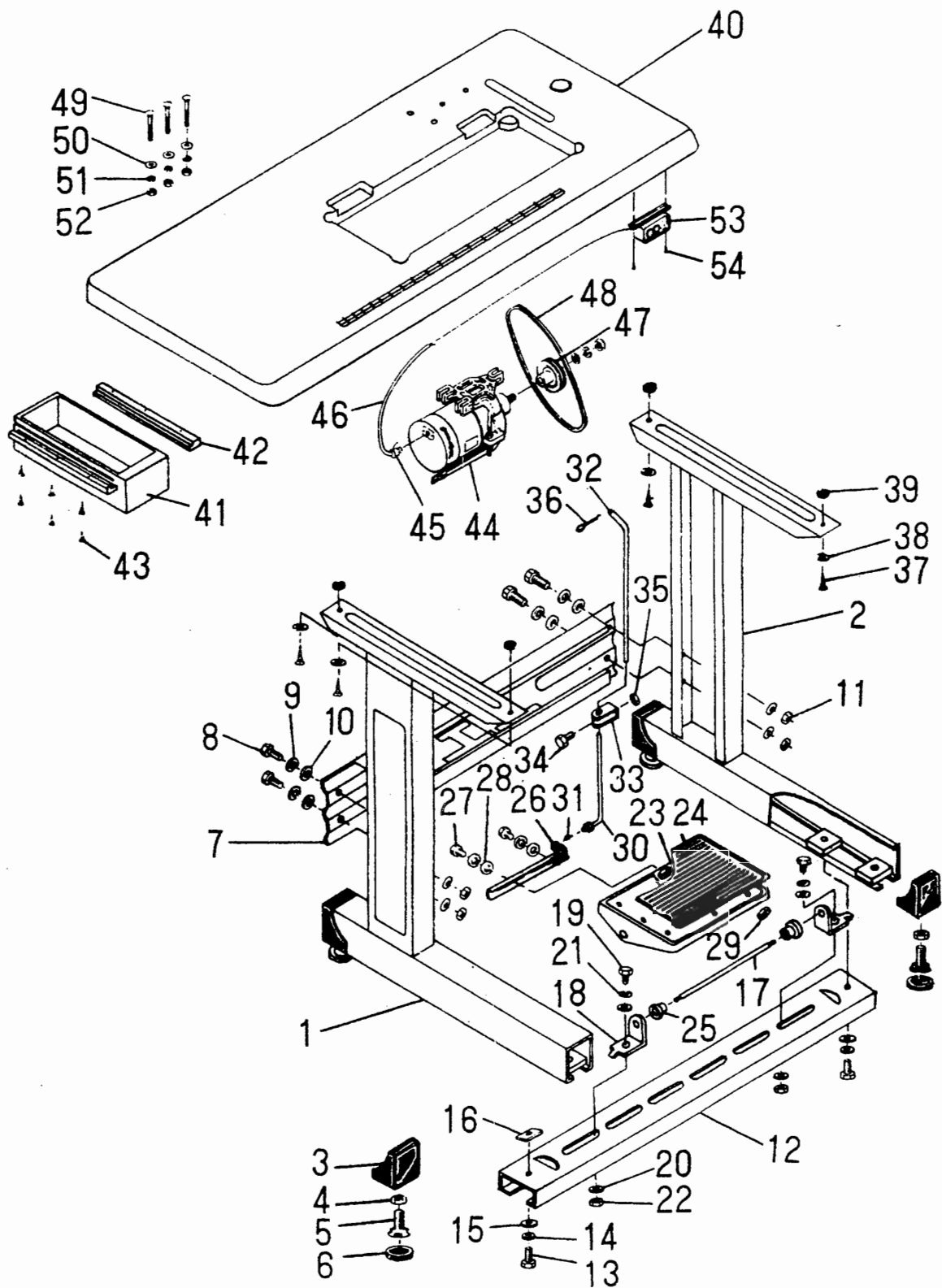

Model 2491D300A (For Heavy Weight Materials)

Ref.No.	Part No.	Description	Amt.
1	GH579/3	Link thread take-up lever asm.	1
2	GH580	Needle bar crank H (1)	(1)
3	GR1644	Thread guide pin 1	1
4	GO288	Needle bar bushing, lower 1	1
5	GR1632	Needle bar thread guide 1	1
6	GZ441	Needle bar 1	1
7	GR3431	Needle bar thread guide 1	1
8	N1955-01(#18)	Needle #18 1	1
9	GW269	Presser spring 1	1
10	GR3433/10	Thread tension asm. 1	1
11	GW268	Tension spring 1	1
12	GR3432	Arm thread guide (HA) 1	1
13	GW440	Adjust link spring 1	1
14	GR3434	Positioning finger 1	1
15	GM210	Throat plate (H) 1	1
16	GM209	Feed dog (H) 1	1
17	GR5132	Needle safety guard 1	1
18	GR1025/4	Presser foot asm. 1	1
19	GN197	Hook asm. 1	1
20	GS069	Screw 1/8-44 L=2.5 1	1
21	GR3435	Feed spring hook 1	1

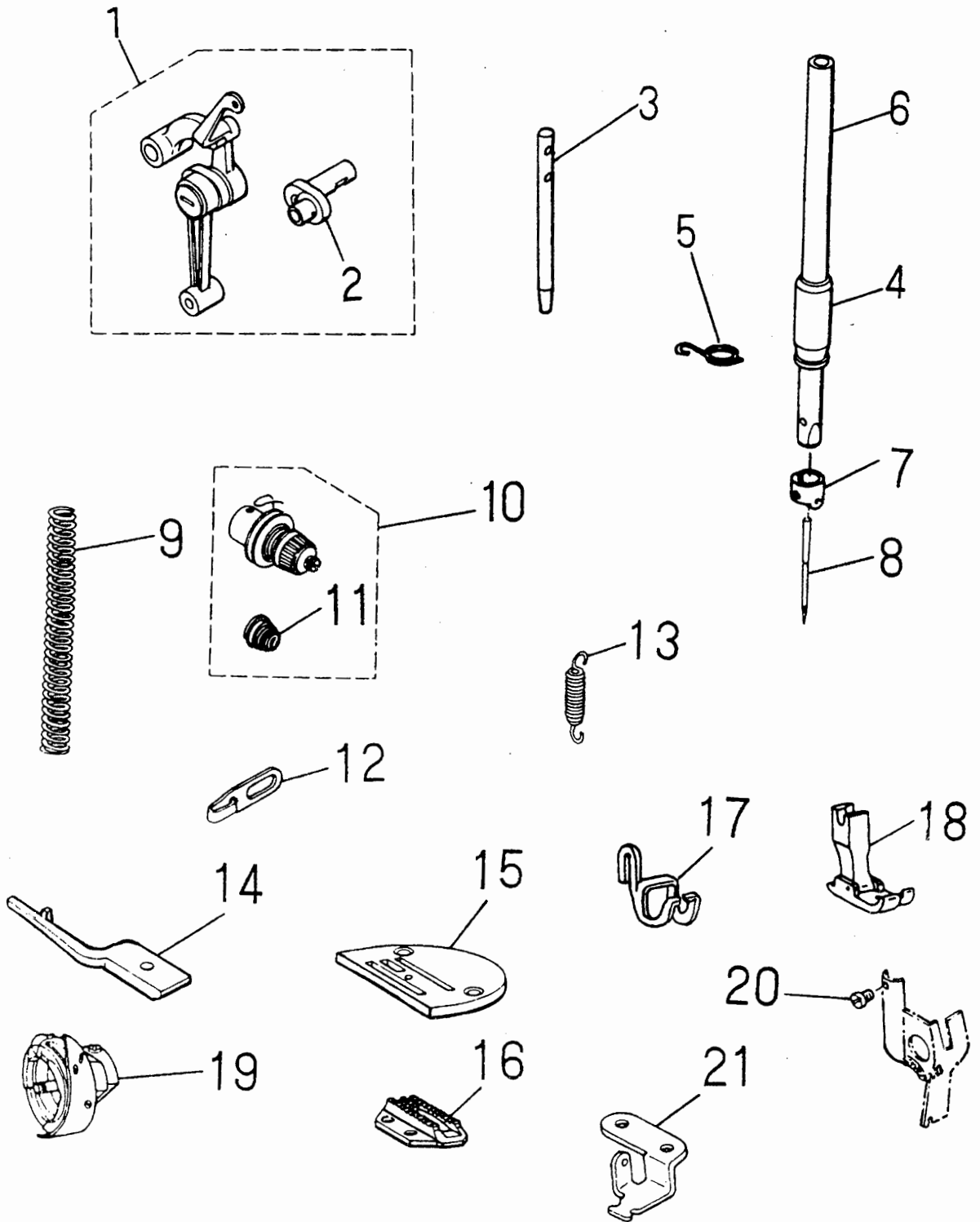

Part No. SY9003 (Rev. 0203)
Printed in China