

Yamato[®]

INDUSTRIAL SEWING MACHINE

**ILLUSTRATED SPARE PARTS LIST
FOR
HIGH SPEED
OVERLOCK MACHINE**

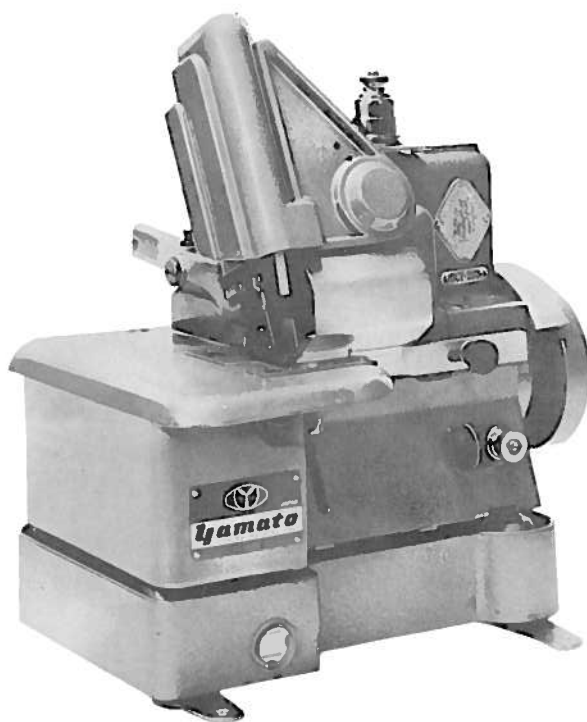

MODEL

DCY-100	DCY-103	DCY-104	DCY-108
DCY-109	DCY-112	DCY-113	DCY-114
DCY-120	DCY-120W	DCY-121	DCY-200
DCY-203	DCY-220	DCY-220W	DCY-223

KONDO SEWING MACHINE CO.,LTD.



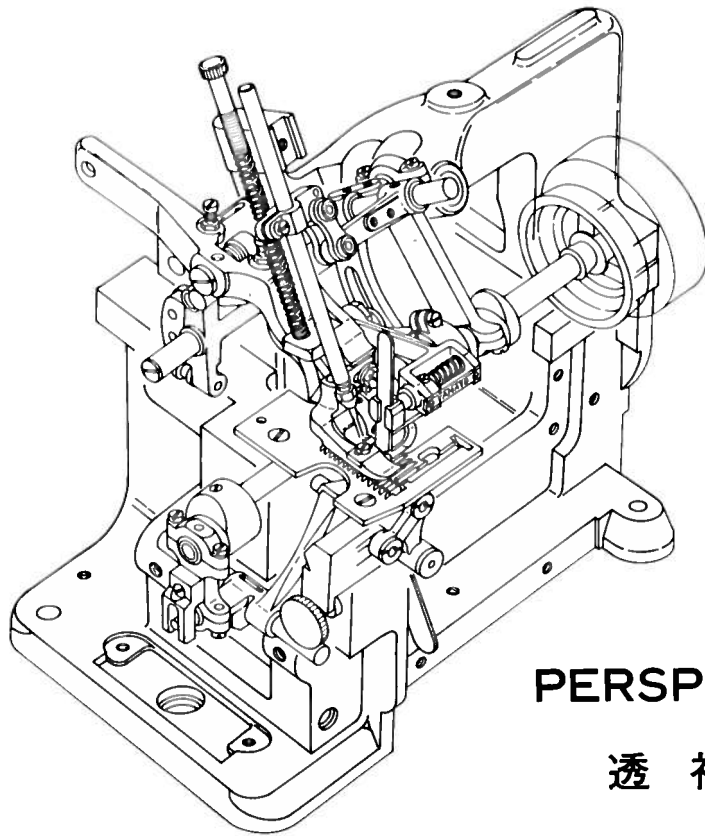

PERSPECTIVE

透視図

CONTENTS

MISCELLANEOUS COVER (1)
MISCELLANEOUS COVER (2)
MISCELLANEOUS THREAD EYELET
NEEDLE BAR DRIVING MECHANISM
LOOPER DRIVING MECHANISM
PRESSER FOOT MECHANISM
FEED DRIVING MECHANISM
TRIMMING KNIFE DRIVING MECHANISM
MISCELLANEOUS BUSHING & MAIN CRANKSHAFT
OIL LUBRICATING SYSTEM
DCY-103,-104,-112,-113,-114 EXCLUSIVE PARTS
DCY-104, -112, -113, -114 EXCLUSIVE PARTS
DCY-108, -109 EXCLUSIVE PARTS (1)
DCY-108, -109 EXCLUSIVE PARTS (2)
DCY-108, -109 EXCLUSIVE PARTS (3)
DCY-108, -109 OIL LUBRICATING SYSTEM
DCY-120, -120W, -121 EXCLUSIVE PARTS
DCY-200, -203, -220, -220W, -221 EXCLUSIVE PARTS
DCY-200 CLASS OIL LUBRICATING SYSTEM
DCY-200, -203, -220, -220W, -221 EXCLUSIVE PARTS
DCY-220, 220W, 221 EXCLUSIVE PARTS
ACCESSORY
INDEX

目次

カバー関係(1)..... 1
カバー関係(2)..... 2
糸道関係..... 3
針棒機構..... 4
ルーパー機構..... 5
押工機構..... 6
送り機構..... 7
メス機構..... 8
プッシュ、クランクシャフト関係..... 9
給油関係.....10
サブクラス専用部品.....11
サブクラス専用部品.....12
サブクラス専用部品.....13
サブクラス専用部品.....14
サブクラス専用部品.....15
サブクラス給油関係.....16
サブクラス専用部品.....17
サブクラス専用部品.....18
サブクラス給油関係.....19
サブクラス専用部品.....20
サブクラス専用部品.....21
アクセサリ.....22
索引.....23

Please always mention our parts number when placing your orders.

部品の御注文は部品番号で!!

1

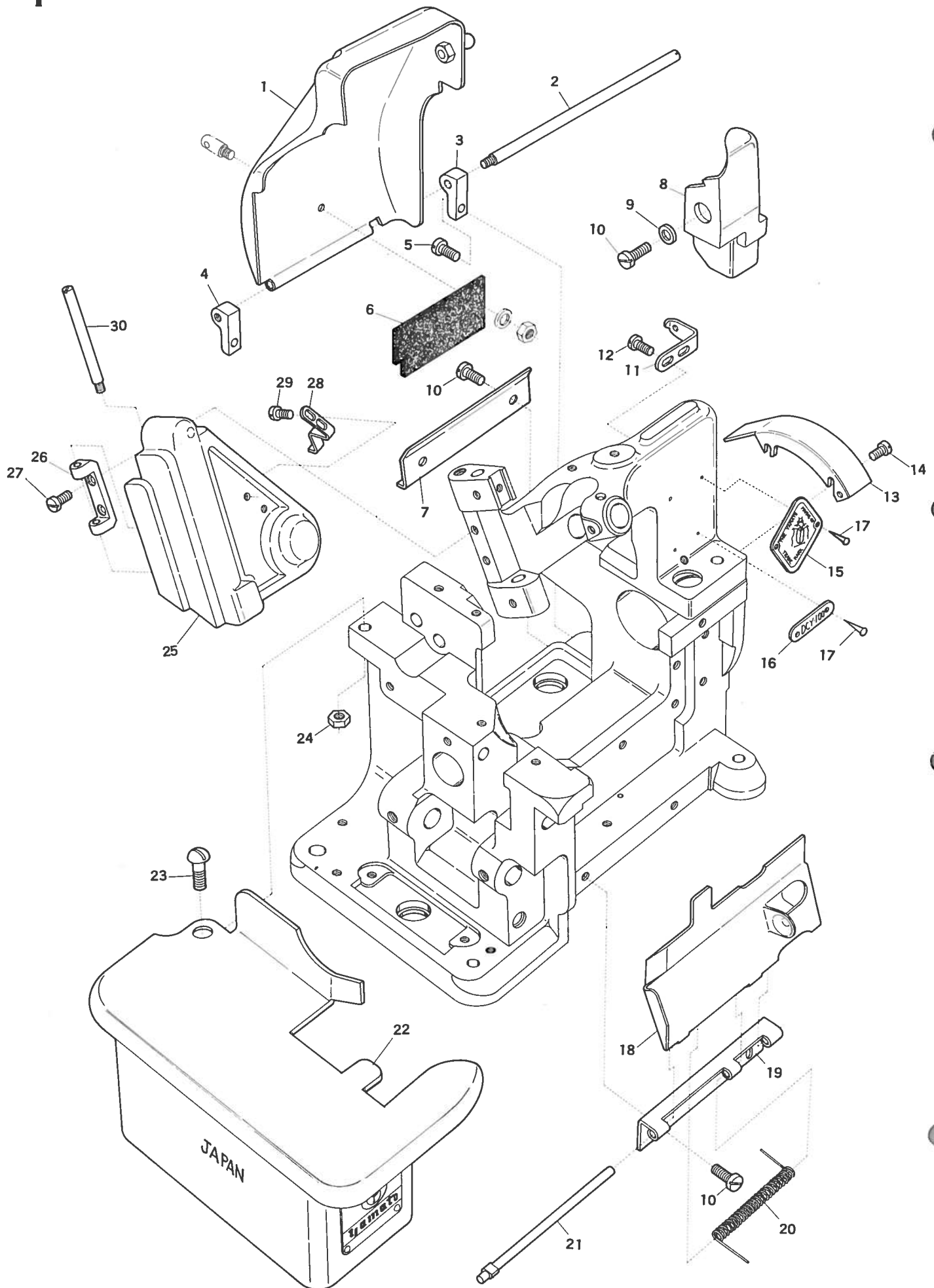

MISCELLANEOUS COVER(1)

カバー関係(1)

1

Ref. No.	Parts No.	Description	品名	Amt. Req.
1	37623	Rear Cover(Open) Complete Set	後開キカバー(組)	1
2	37612	Rear Cover Hinge Pin	後開キカバーピン	1
3	37609	Rear Cover Hinge(Right)	後開キカバーヒンジ(ピン穴付)	1
4	37610	Rear Cover Hinge(Left)	後開キカバーヒンジ(ネジ穴付)	1
5	7609	Screw for 37690, 37610	後開キカバーヒンジ止ネジ	2
6	37569	Rear Cover Felt	後開キカバーフェルト	1
7	38229	Rear Oil Shield	ベツト油除ケ	1
8	37622	Front Cover(Fix)	大ロット前カバー	1
9	541	Washer for 37622	座金	1
10	1175	Screw for 37622, 37605, 38229	止ネジ	5
11	37613	Rear Cover Spring	後開キカバーバネ	1
12	1196	Screw for 37613	後開キカバーバネ止ネジ	2
13	37544	Belt Cover	ベルトカバー	1
14	1208	Screw for 37544	ベルトカバー止ネジ	2
15	901	Indicate Plate	銘板	1
16	37628	Model Indicate Plate	型式板	1
17	726	Rivet for 901, 37628	止メ鉄	4
18	37604	Front Cover	前開キカバー	1
19	37605	Front Cover Hinge	前開キカバー取り付け台	1
20	37607	Front Cover Restoring Spring	前開キカバーバネ	1
21	37606	Front Cover Hinge Pin	前開キカバーピン	1
22	37696	Cloth Plate Complete Set	大カバー(組)	1
23	2419	Screw for 37696	大カバー(組)止ネジ	1
24	144	Nut for 37696	ナット	1
25	37615	Needle Bar Cover	針棒カバー	1
26	37616	Needle Bar Connecting Link Cover Bracket	針棒カバー取り付け台	1
27	7616	Screw for 37616	針棒カバー取り付け台止ネジ	2
28	37618	Needle Bar Cover Latch Spring	針棒カバーバネ	1
29	7618	Screw for 37618	針棒カバーバネ止ネジ	2
30	37617	Needle Bar Connecting Link Cover Pin	針棒カバーピン	1

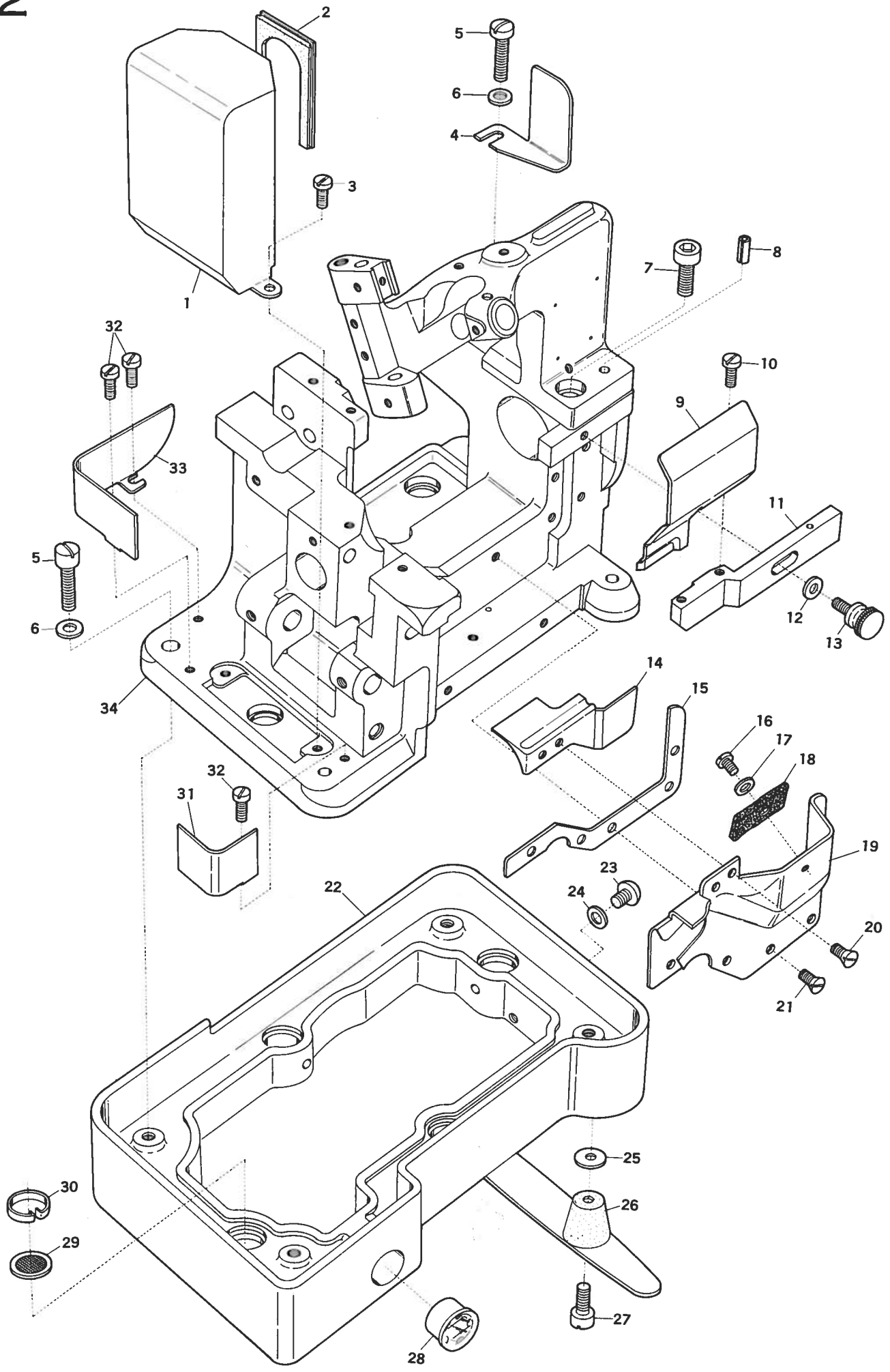

Ref. No.	Parts No.	Description	品名	Amt. Req.
1	37624	Looper Connecting Rod Cover	小ロットカバー	1
2	37699	Looper Connecting Rod Cover Gasket	小ロットカバーパッキン	1
3	2237	Screw for 37624	小ロットカバー止ネジ	2
4	37709	Dust Plate	ダストプレート	1
5	7763	Screw for 37678	ベース止ネジ	4
6	562	Washer for 37678	座金	4
7	9091	Screw for 37601	アーム止ネジ	2
8	710	Pin for 37601	アームノックピン	2
9	37638	Chip Guard (Upper)	切屑除ケ	1
10	1175	Screw for 37638	切屑除ケ止ネジ	2
11	37637	Chip Guard Holder	角台	1
12	554	Washer for 37637	座金	1
13	1218	Screw for 37637	角台止ネジ	1
14	37621	Front Oil Shield (Upper)	ウオームカバー	1
15	37620	Front Oil Shield Gasket	前カバーパッキン	1
16	7618	Screw for 37692	前カバーフェルト止ネジ	1
17	531	Washer for 37692	座金	1
18	37692	Front Oil Shield Felt	前カバーフェルト	1
19	37619	Front Oil Shield (Lower)	前カバー	1
20	1613	Screw for 37621	ウオームカバー止ネジ	2
21	7619	Screw for 37619	前カバー止ネジ	5
22	37678	Base	ベース	1
23	7678	Screw for 37678	ベース止ネジ	1
24	578	Washer for 37678	座金	1
25	568	Washer for 37540	座金	4
26	37540	Base Rubber Cushion Complete Set	ベースゴム座(組)	1
27	5083	Screw for 37540	ベースゴム座(組)止ネジ	4
28	37679	Oil Sight Gauge	オイルゲージ	1
29	37680	Round Oil Filter Screen	円形濾過網	6
30	37681	Round Oil Filter Screen Clamp	円形濾過網押エ	6
31	37627	Angle Cover (Small)	角カバー(小)	1
32	1208	Screw for 37627, 37626	角カバー止ネジ	3
33	37626	Angle Cover (Large)	角カバー(大)	1
34	37601	Machine Frame	アームベット	1

3

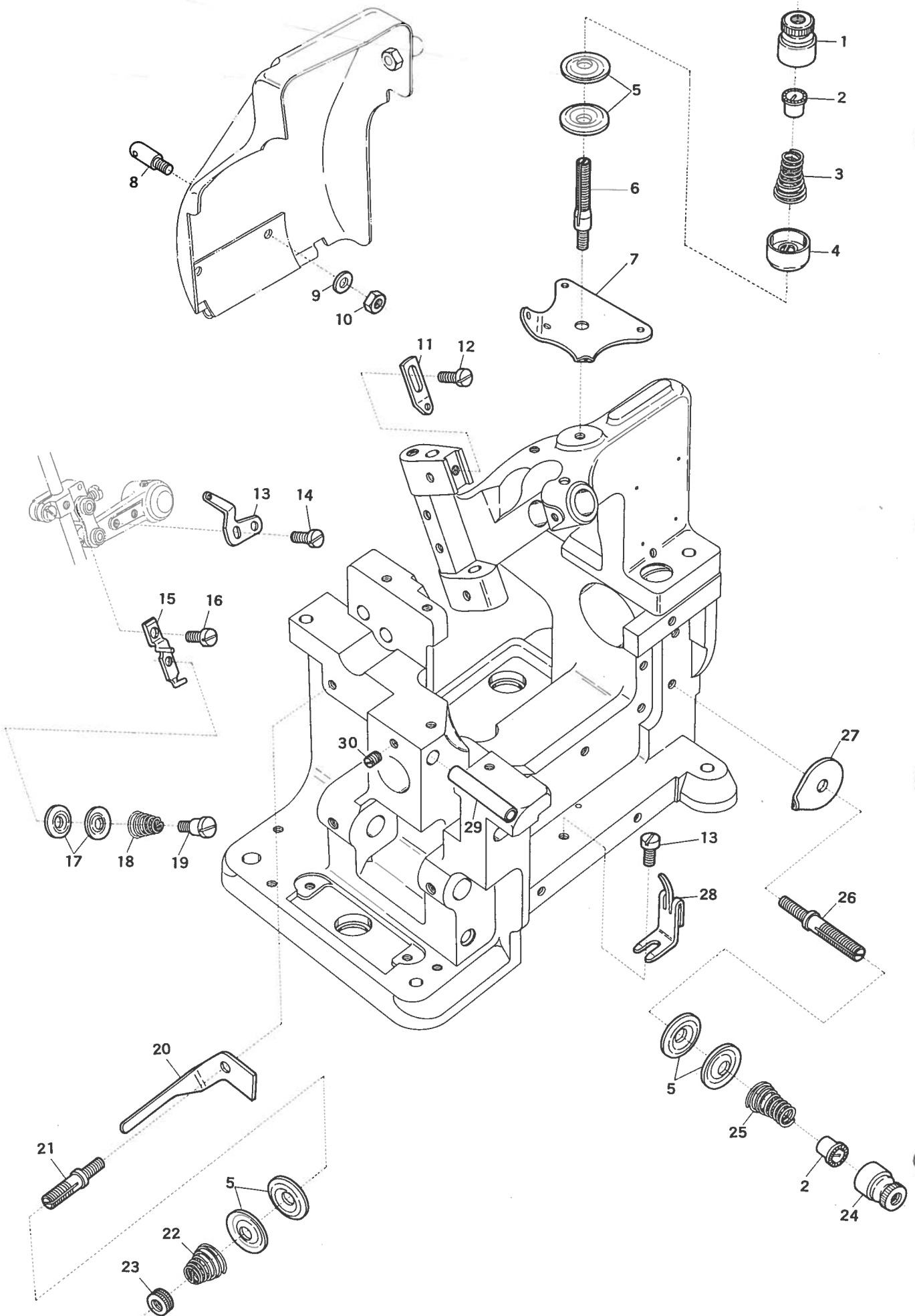

Ref. No.	Parts No.	Description	品名	Amt. Req.
1	37634	Thread Tension Spring Cap	渦巻バネキャップ(上)	1
2	37170	Tension Spring Bushing Complete Set	糸調子ナット廻り止メ(組)	2
3	37633	Needle Thread Tension Spring	渦巻バネ(太)	1
4	37635	Thread Tension Retainer	渦巻バネキャップ(下)	1
5	31111	Tension Disc	調子皿	6
6	37904	Tension Post	糸調子棒	1
7	38105	Tension Disc Eyelet for Needle Thread	上糸調子台	1
8	362	Rear Cover Thread Eyelet	後開キカバー糸道	2
9	444	Washer for 38362	座金	2
10	330	Nut for 38362	ナット	2
11	37101	Needle Thread Eyelet	上糸道	1
12	4358	Screw for 37101	上糸道止ネジ	1
13	37102	Needle Thread Swing Eyelet	上糸振り糸道	1
14	1196	Screw for 37102	上糸振り糸道止ネジ	2
15	37107	Needle Bar Thread Retainer Bracket	小調子台	1
16	1227	Screw for 37107	小調子台止ネジ	1
17	37108	Needle Bar Thread Retainer Disc	小調子皿	2
18	37109	Needle Bar Thread Retainer Spring	小調子バネ	1
19	1092	Screw for 37109	小調子バネ止ネジ	1
20	37016	Side Thread Latch	横糸掛け	1
21	1817	Tension Post	糸調子棒	1
22	37115	Looper Thread Tension Spring	渦巻バネ(極細)	1
23	56	Adjusting Nut	調節ツマミ	1
24	37636	Thread Tension Spring Cap	渦巻バネキャップ(小)	1
25	37632	Upper Looper Thread Tension Spring	渦巻バネ(細)	1
26	7817	Tension Post	糸調子棒	1
27	37106	Tension Disc Eyelet for Upper Thread	前糸調子台	1
28	37104	Upper Looper Thread Hook	三ツ又糸道	1
29	37103	Lower Looper Threading Tube	糸道パイプ	1
30	1457	Screw for 37103	糸道パイプ止ネジ	1

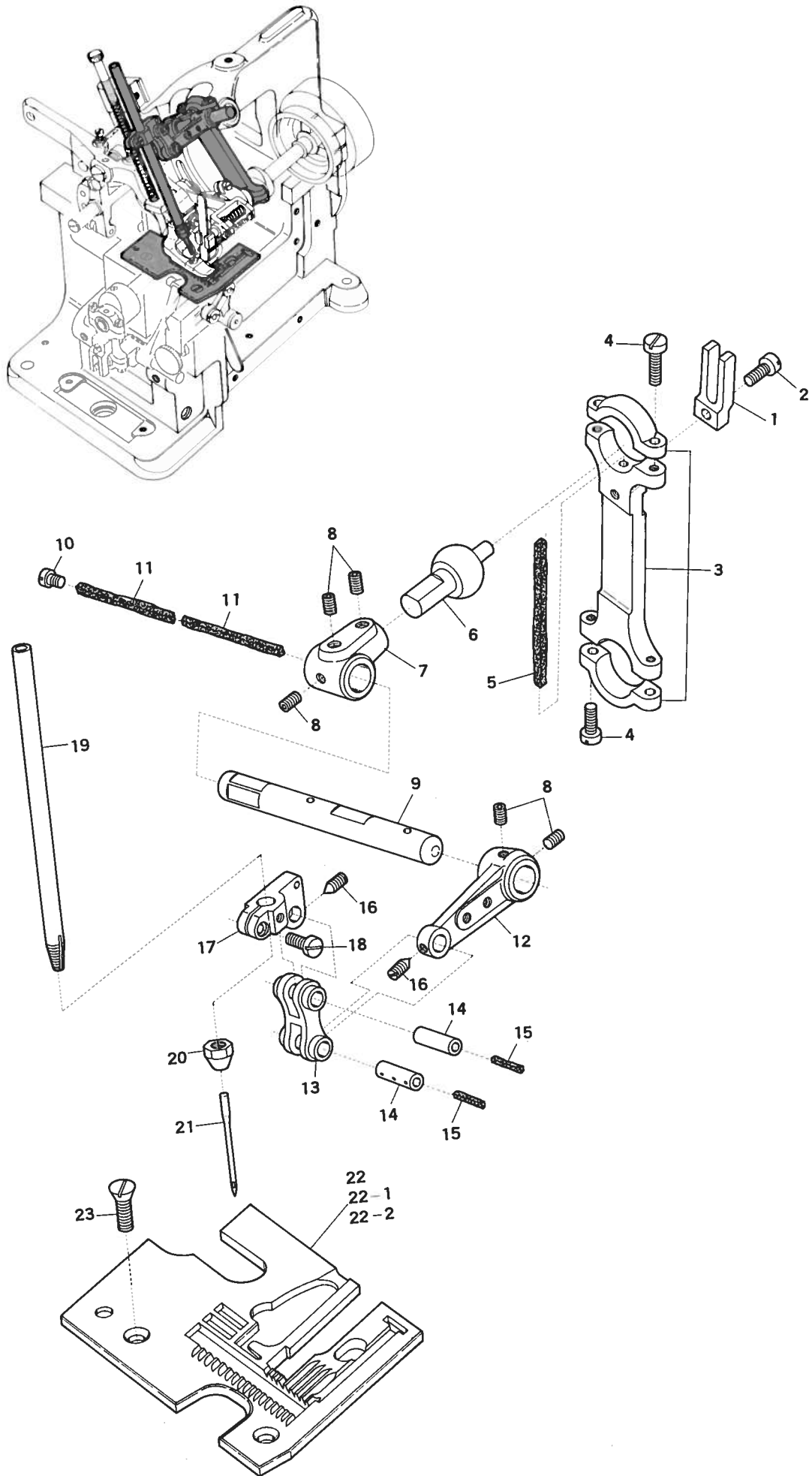

Ref. No.	Parts No.	Description	品名	Amt. Req.
1	37130	Needle Bar Connecting Rod Guide Fork	振り止メ	1
2	1170	Screw for 37130	振り止メ止ネジ	1
3	37120	Needle Bar Connecting Rod	大ロット	1
4	7311	Screw for 37120	大ロット止ネジ	4
5	304	Felt for 37120	油芯	1
6	37132	Needle Bar Driving Crank Ball Stud	球(穴付)	1
7	37127	Needle Bar Driving Crank(Rear)	針棒後クランク	1
8	3635	Screw for 37132,37127,37150	止ネジ	5
9	37128	Needle Bar Driving Crankshaft	針棒クランク軸	1
10	9932	Screw for 37128	針棒クランク軸止ネジ	1
11	291	Felt for 37128	油芯	2
12	37150	Needle Bar Driving Crank (Front)	針棒前クランク	1
13	90321	Needle Bar Connecting Link	針棒リンク	1
14	90320	Needle Bar Connecting Link Pin	針棒リンクピン	2
15	282	Felt for 90320	油芯	2
16	3311	Screw for 90320	針棒リンクピン止ネジ	2
17	37151	Needle Bar Connecting Bracket	針棒抱キ	1
18	1186	Screw for 37151	針棒抱キ止ネジ	1
19	37122	Needle Bar	針棒	1
20	62	Nut for 37122	ナット	1
21	—	Needle	針	1
22	38506	Throat Plate for Tongue Width 1.6 mm	針板 1.6ミリ	1
22-1	38507	Throat Plate for Tongue Width 2.3 mm	針板 2.3ミリ	1
22-2	38508	Throat Plate for Tongue Width 3.3 mm	針板 3.3ミリ	1
23	1732	Screw for 38506,38507,38508	針板止ネジ	2

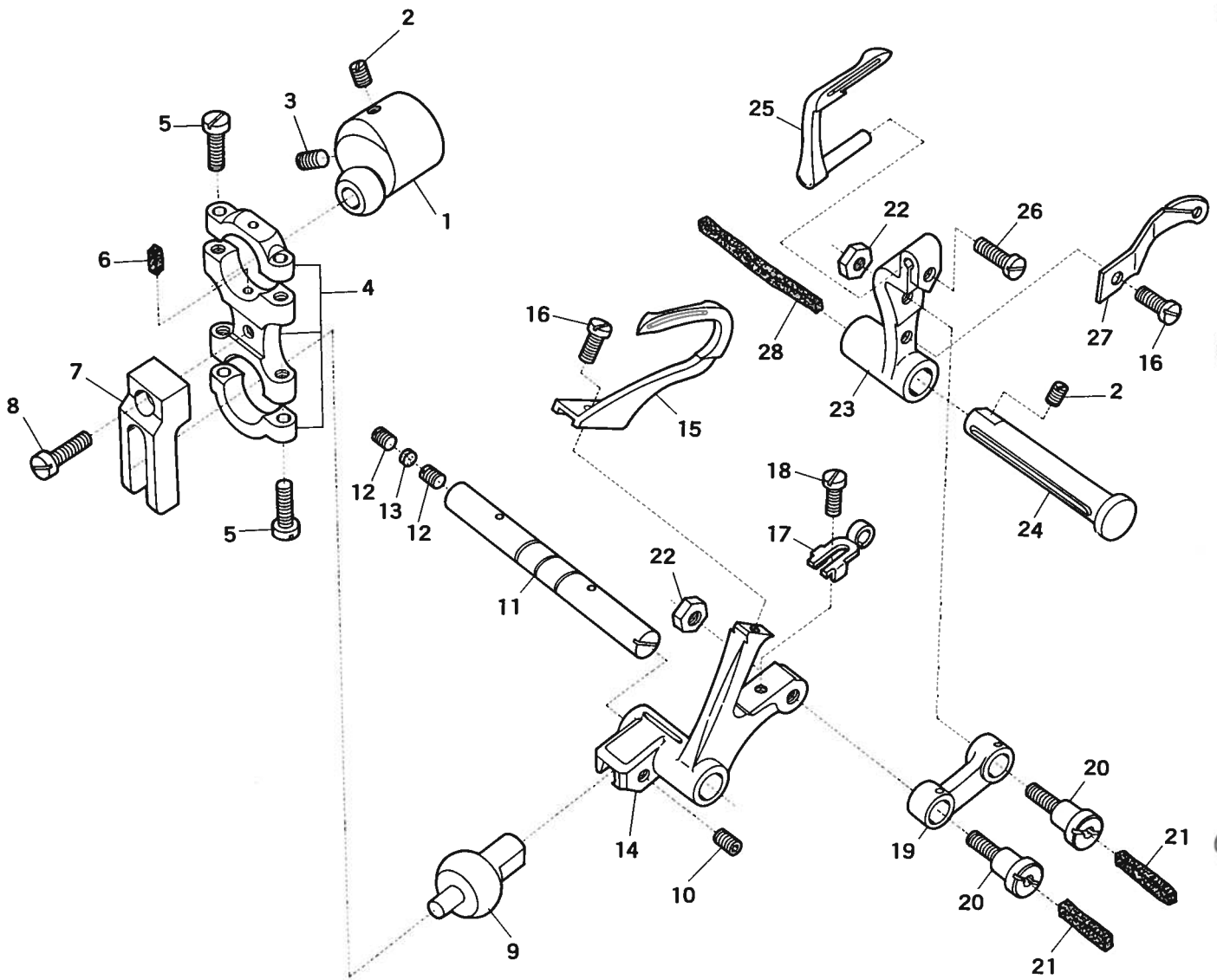
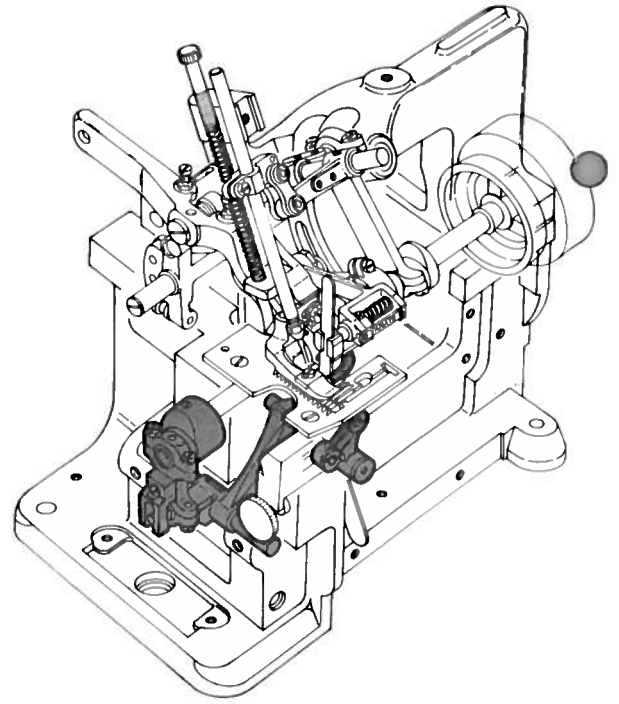

Ref. No.	Parts No.	Description	品名	Amt. Req.
1	37690	Looper Driving Crankshaft	エキセンクランク	1
2	2022	Screw for 37690	止ネジ	2
3	2368	Screw for 37690	エキセンクランク止ネジ	1
4	37311	Looper Connecting Rod	小ロット	1
5	7311	Screw for 37311	小ロット止ネジ	4
6	—	Felt for 37311	油芯	1
7	37130	Looper Connecting Rod Guide Fork	振り止め	1
8	1170	Screw for 37130	振り止め止ネジ	1
9	37121	Driving Lever Ball Stud	球	1
10	3635	Screw for 37121	球止ネジ	1
11	37647	Upper Looper Shaft	大ルーパー軸	1
12	1457	Screw for 37647	止ネジ	2
13	925	Plug for 37647	埋メ座	1
14	37304	Upper Looper Holder Arm	大ルーパー台	1
15	37301	Upper Looper	大ルーパー	1
16	1196	Screw for 37301	大ルーパー止ネジ	1
17	37307	Upper Looper Thread Pull-off	大ルーパー台糸道	1
18	4237	Screw for 37307	大ルーパー台糸道止ネジ	1
19	37315	Lower Looper Connection Link	ルーパーリンク	1
20	1335	Screw for 37315	ルーパーリンク止ネジ	2
21	290	Felt for 37315	油芯	2
22	18	Nut for 37315	ナット	2
23	37648	Lower Looper Holder Arm	小ルーパー台	1
24	37649	Lower Looper Shaft	小ルーパー軸	1
25	37302	Lower Looper	小ルーパー	1
26	7302	Screw for 37302	小ルーパー止ネジ	1
27	37308	Upper Looper Thread Pull-off	大ルーパー糸引き	1
28	—	Felt for 37649	油芯	1

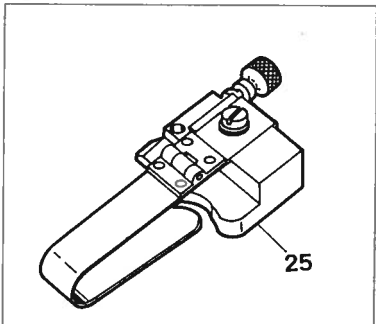
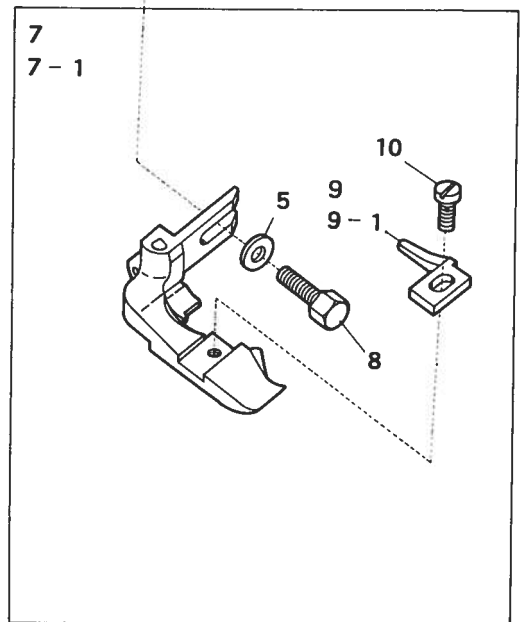
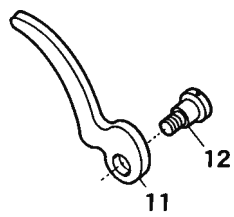
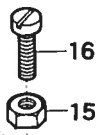
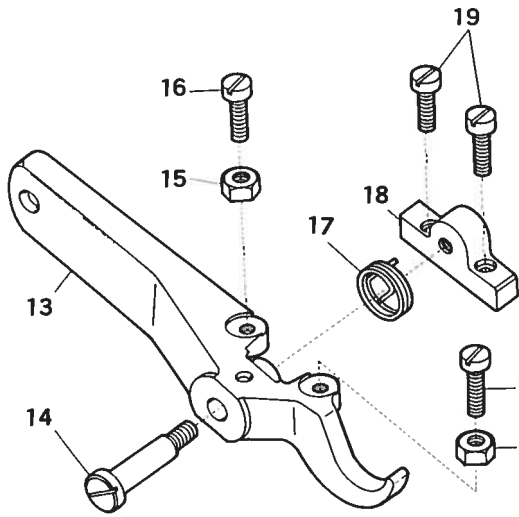
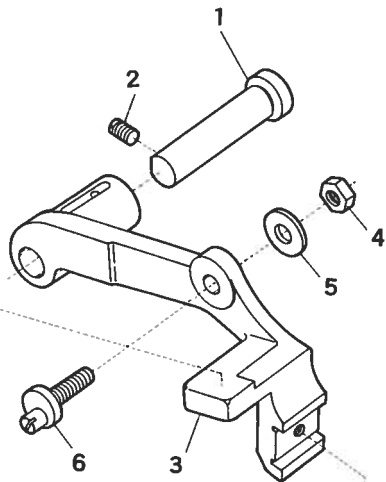
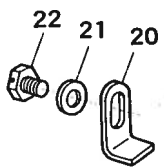
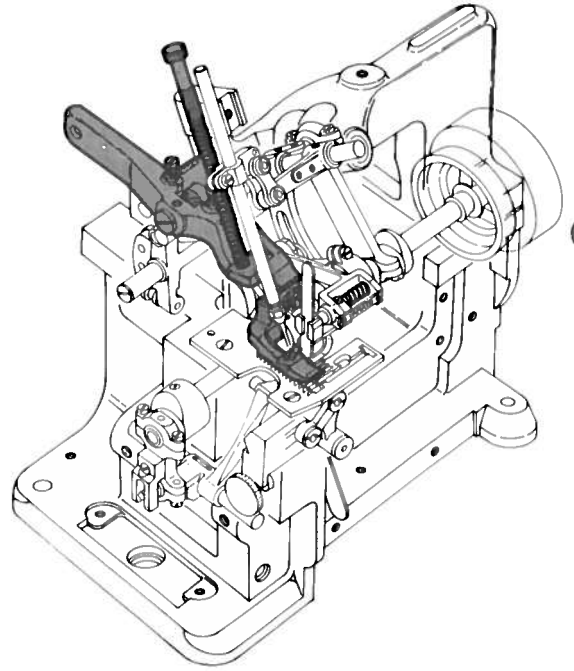

Ref. No.	Parts No.	Description	品名	Amt. Req.
1	37552	Presser Arm Hinge Stud	押エ台ピン	1
2	3434	Screw for 37552	押エ台ピン止ネジ	1
3	37140	Presser Arm	押エ台	1
4	340	Nut for 37140	ナット	1
5	554	Washer for 3714, 37500, 37533	座金	2
6	7143	Eccentric Screw Stud	エキセンネジ	1
7	37500	Presser Foot Complete Set for Tongue Width 1.2mm	押エ(組) 1.2ミリ	1
7-1	37533	Presser Foot Complete Set for Tongue Width 3mm	押エ(組) 3ミリ	1
8	2308	Screw for 37500, 37533	押エ(組)止ネジ	1
9	37163	Presser Foot Stitch Tongue for Tongue Width 1.2mm	爪 1.2ミリ	1
9-1	37529	Presser Foot Stitch Tongue for Tongue Width 3mm	爪 3ミリ	1
10	1228	Screw for 37163, 37529	爪止ネジ	1
11	37144	Foot Lifter Hand Lever	押エ手揚げ	1
12	2214	Screw for 37144	押エ手揚げ止ネジ	1
13	37146	Foot Lifter Lever	押エ足揚げ	1
14	2285	Screw for 37146	押エ足揚げ止ネジ	1
15	334	Nut for 37146	ナット	2
16	2133	Screw for 37146	押エ足揚げ止ネジ	2
17	37147	Foot Lifter Lever Spring	押エ足揚げバネ	1
18	37145	Foot Lifter Lever Bracket	押エ足揚げ台	1
19	7311	Screw for 37145	押エ足揚げ台止ネジ	2
20	37148	Presser Arm Stopper	押エ台ストッパー	1
21	530	Washer for 37148	座金	1
22	5541	Screw for 37148	押エ台ストッパー止ネジ	1
23	37141	Presser Spring	押エバネ	1
24	2371	Screw for 37141	押エバネ止ネジ	1
25	37930	Hemming Guide Complete Set	スソ引定規(組)	1

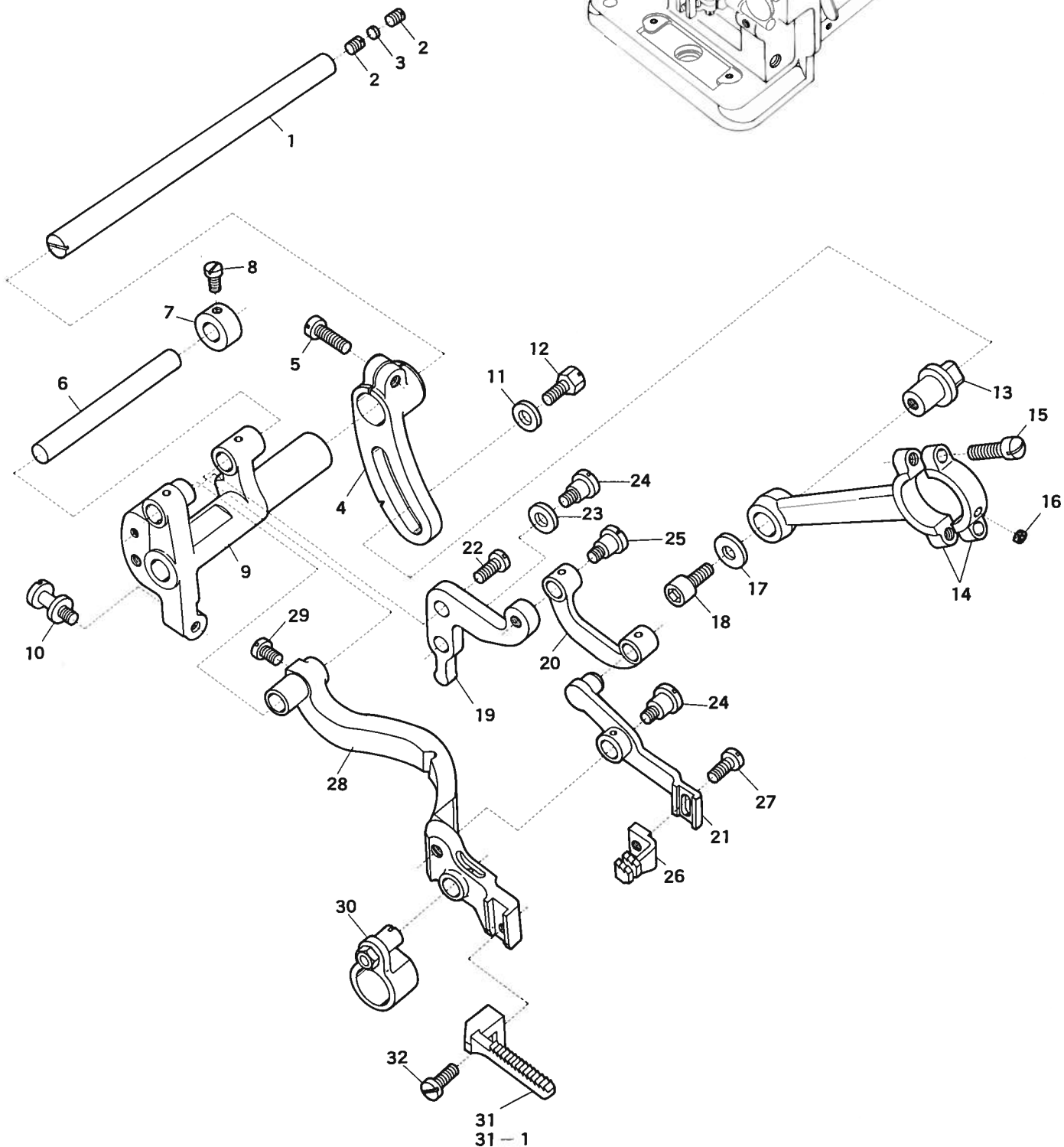
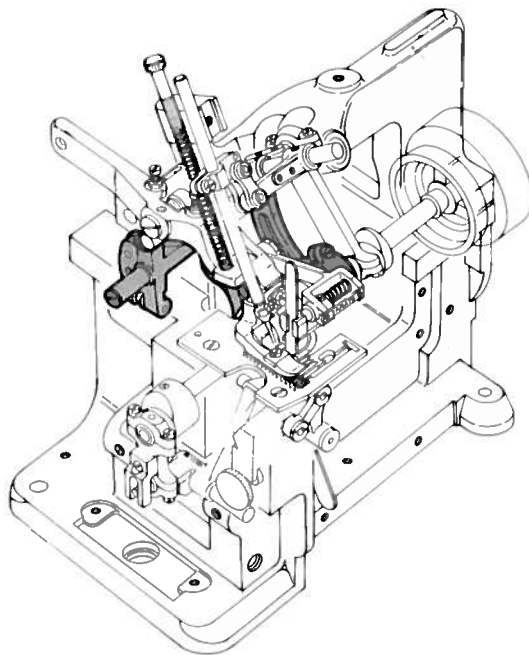

Ref. No.	Parts No.	Description	品名	Amt. Req.
1	37653	Feed Bar Shaft	送り台シャフト	1
2	1457	Screw for 37653	送り台シャフト止ネジ	2
3	925	Feed Bar Shaft Gasket	パッキン	1
4	37652	Feed Regulator	大送り調節器	1
5	1156	Screw for 37652	大送り調節器止ネジ	1
6	37442	Feed Holder Pin	大送り取り付ケピン	1
7	37443	Feed Holder Pin Collar	大送り取り付ケピンカラー	1
8	7616	Screw for 37443	大送り取り付ケピンカラ止ネジ	1
9	37402	Differential Feed Rocker	送りロックシャット	1
10	7425	Screw for 37405	小送り調節器調節ネジ	1
11	551	Washer for 38064	座金	1
12	5540	Screw for 38064	送りロットピン止ネジ	1
13	38064	Feed Dog Driving Connecting Rod Pin	送りロットピン	1
14	37651	Feed Dog Driving Connecting Rod	送りロット(組)	1
15	2043	Screw for 37651	送りロット(組)止ネジ	2
16	281	Felt for 37651	フェルト	1
17	555	Washer for 38064	座金	1
18	5028	Screw for 38064	送りロットピン止ネジ	1
19	37405	Auxiliary Feed Regulator	小送り調節器	1
20	37406	Auxiliary Feed Driving Connection	小送りリンク	1
21	37416	Auxiliary Feed Holder	小送り取り付ケ台	1
22	7405	Screw for 37405	小送り調節器止ネジ	1
23	511	Washer for 37405	座金	1
24	1060	Screw for 37405, 37416	止ネジ	2
25	2127	Screw for 37406	小送りリンク止ネジ	1
26	37456	Auxiliary Feed Dog	小送り	1
27	1202	Screw for 37456	小送り止ネジ	1
28	37415	Plain Feed Dog Holder	大送り取り付ケ台	1
29	2237	Screw for 37415	大送り取り付ケ台止ネジ	1
30	37410	Feed Dog Driving Lever	送り上下ダルマ	1
31	37455	Plain Feed Dog	大送り	1
31-1	37249	Feed Dog (Exclusive)	送り(オプション)	1
32	1175	Screw for 37455, 37249	止ネジ	1

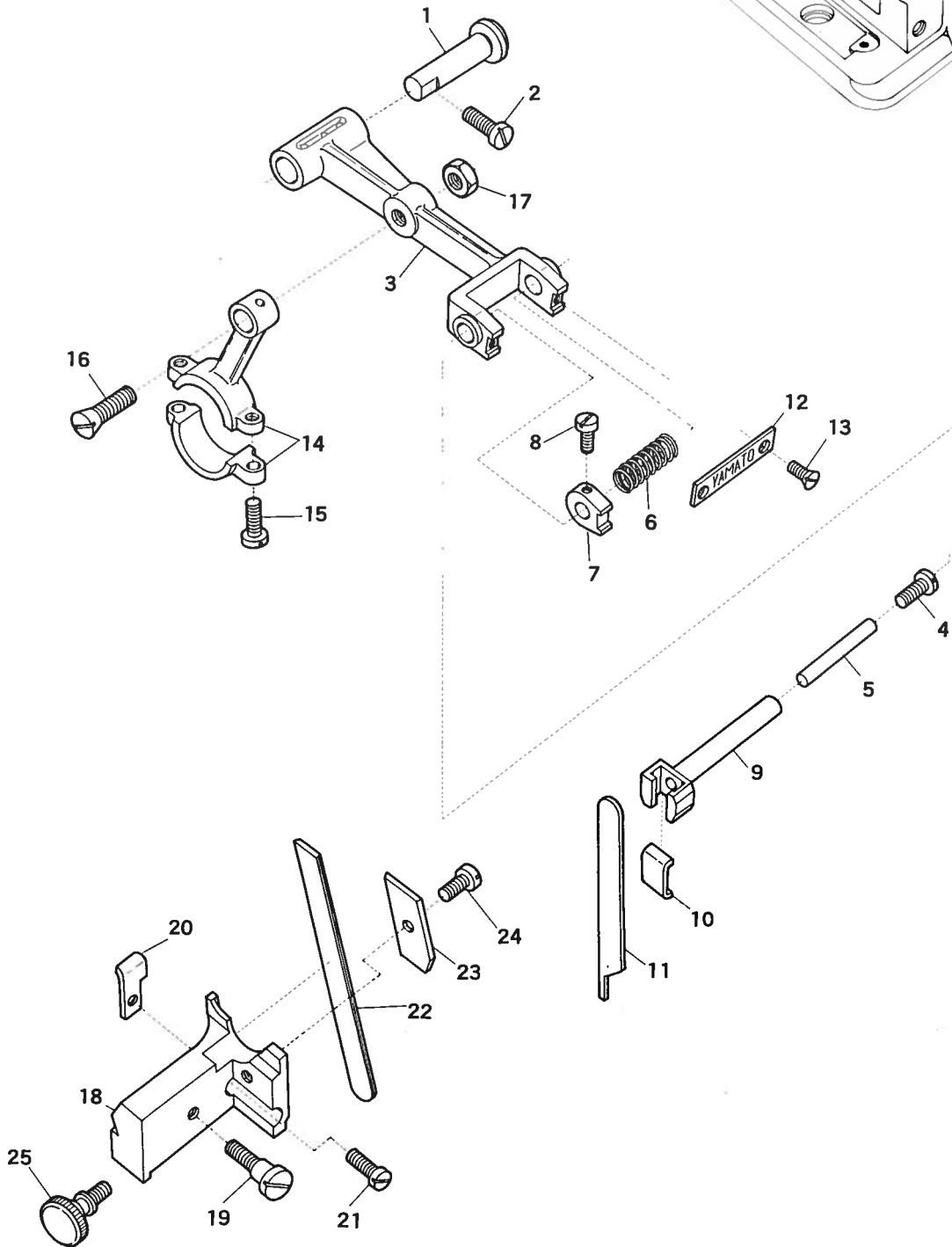
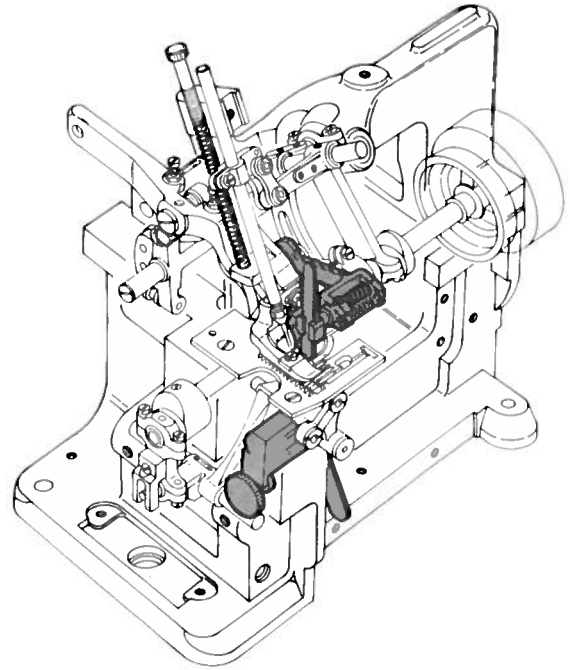

<u>Ref. No.</u>	<u>Parts No.</u>	<u>Description</u>	<u>品 名</u>	<u>Amt. Req.</u>
1	37552	Upper Knife Driving Arm Stud Pin	上メス台ピン	1
2	7311	Screw for 37552	上メス台ピン止ネジ	1
3	37509	Upper Knife Driving Arm Stud	上メス台	1
4	1132	Screw for 37514	上メス止ネジ	1
5	37560	Upper Knife Clamp Pin	上メス押シピン	1
6	37558	Upper Knife Holder Spring	上メスバネ	1
7	37554	Upper Knife Holder Guide	上メス案内	1
8	1227	Screw for 1227	上メス案内止ネジ	1
9	37510	Upper Knife Holder	上メス抱キ	1
10	37512	Upper Knife Clamp	上メス押シ	1
11	37514	Upper Knife	上メス	1
12	37553	Upper Knife Holder Guide Plate	上メス案内板	1
13	1613	Screw for 37553	上メス案内板止ネジ	2
14	37508	Upper Knife Driving Connecting Rod	上メスロット(組)	1
15	1174	Screw for 37508	上メスロット(組)止ネジ	2
16	7509	Screw for 37508	上メスロット(組)止ネジ	1
17	18	Nut for 37508	ナット	1
18	37536	Lower Knife Holder	下メス台	1
19	2086	Screw for 37536	下メス台止ネジ	1
20	37564	Needle Guard	針受ケ	1
21	1174	Screw for 37564	針受け止ネジ	1
22	37538	Lower Knife	下メス	1
23	37537	Lower Knife Clamp	下メス押工	1
24	4353	Screw for 37537	下メス押工止ネジ	1

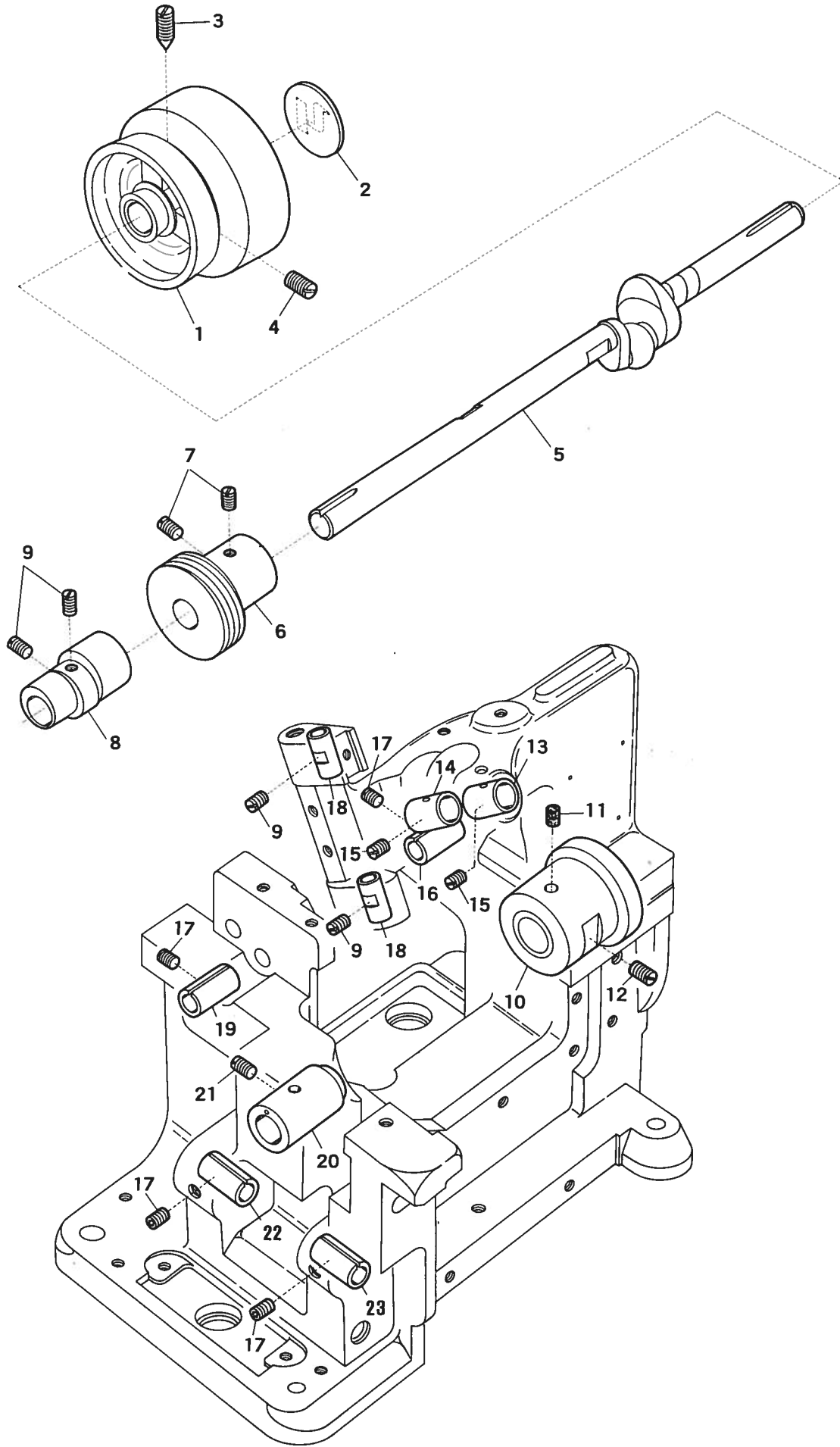

MISCELLANEOUS BUSHING & MAIN CRANK SHAFT

ブッシュ、クランクシャフト関係

9

Ref. No.	Parts No.	Description	品名	Amt. Req.
1	37703	Pulley	プーリー	1
2	989	Hand Wheel Mark	ハンドホイールマーク	1
3	3591	Screw for 37703	プーリー止ネジ	1
4	3593	Screw for 37703	プーリー止ネジ	1
5	37545	Main Crankshaft	クランクシャフト	1
6	37650	Feed Driving Eccentric	片エキセン	1
7	7650	Screw for 37650	片エキセン止ネジ	2
8	37507	Feed Lift and Upper Knife Driving Eccentric	両エキセン	1
9	1457	Screw for 37507, 37049	止ネジ	4
10	37547	Crank Shaft Bushing (Right)	大ブッシュ	1
11	294	Felt for 37547	油芯	1
12	3639	Screw for 37547	大ブッシュ止ネジ	1
13	37133	Needle Bar Driving Crank Bushing (Front)	針棒クランク軸ブッシュ(前)	1
14	37134	Needle Bar Driving Crank Bushing (Rear)	針棒クランク軸ブッシュ(後)	1
15	3434	Screw for 37133, 37134	針棒クランク軸ブッシュ止ネジ	2
16	37654	Feed Bar Shaft Bushing (Right)	割ブッシュ(穴アリ)	1
17	3635	Screw for 37654, 37409	割ブッシュ止ネジ	4
18	37049	Needle Bar Bushing	針棒ブッシュ	2
19	37409	Feed Bar Shaft Bushing (Left)	割ブッシュ(穴ナシ)	2
20	37645	Crank Shaft Bushing (Middle)	割ブッシュ(穴アリ)	1
21	2022	Screw for 37645	割ブッシュ止ネジ	1
22	37654	Upper Looper Shaft Bushing (Rear) (Common to Ref. No. 16)	割ブッシュ	1
23	37409	Upper Looper Shaft Bushing (Front) (Common to Ref. No. 19)	割ブッシュ	1

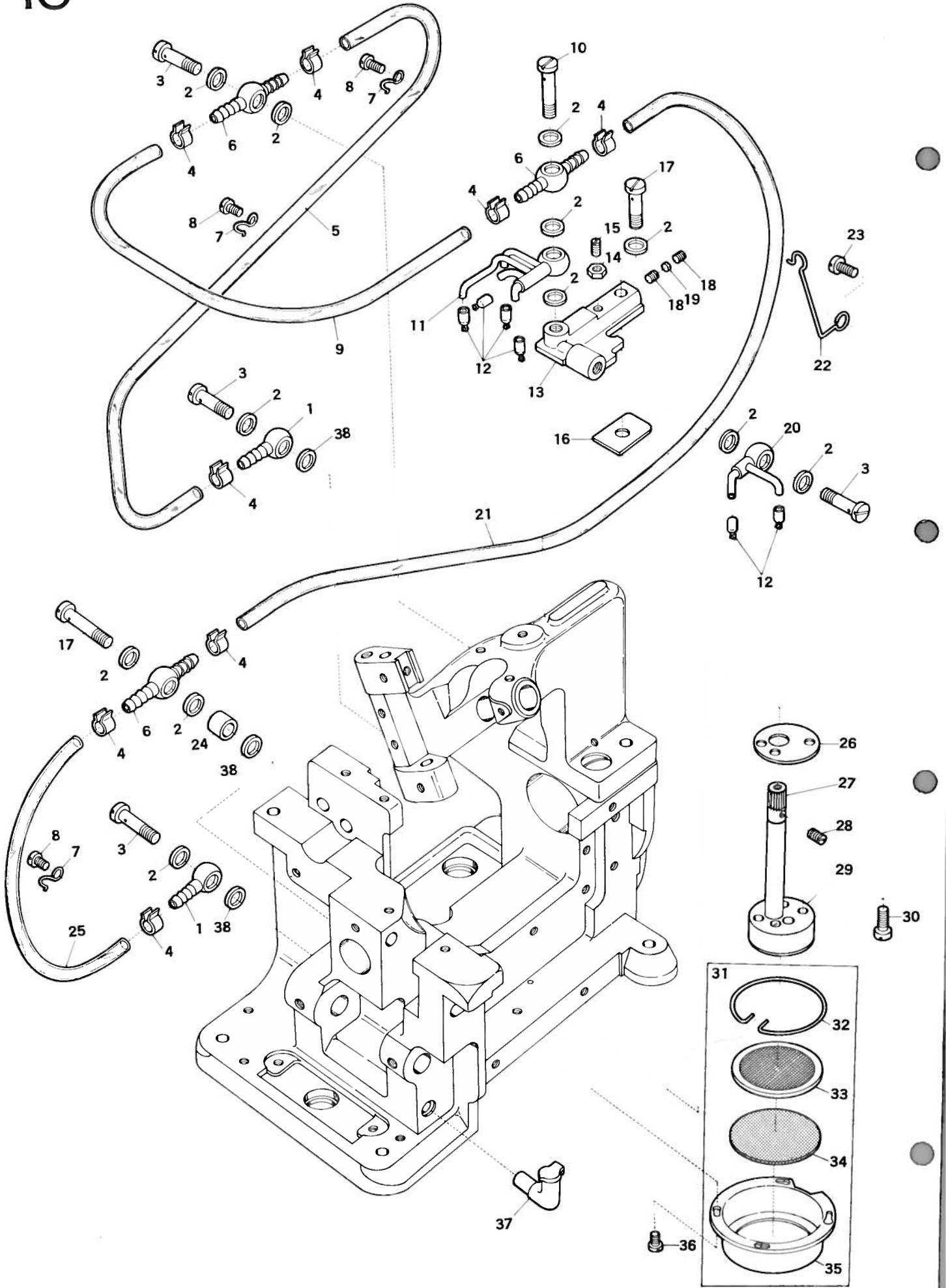

Ref. No.	Parts No.	Descripti	Description	品名	Amt. Req.
1	37669	Oil Tube Fitting One Way End	片口管継当	片口管継当	2
2	567	Washer for 37671, 37669, 37669, 37691, 37670	座金	座金	12
3	7668	Oil Tube Fitting End Bolt (Short)	管継手ボルト(短)	管継手ボルト(短)	4
4	37675	Oil Tube Clamp	緊束環	緊束環	8
5	37433	Oil Tube (217 mm)	ビニールパイプ(217ミリ)	ビニールパイプ(217ミリ)	1
6	37668	Oil Tube Fitting Two End	両口管継手	両口管継手	3
7	37677	Oil Tube Holder (Small)	パイプ支エ(小)	パイプ支エ(小)	3
8	1196	Screw for 37677	パイプ支エ(小)止ネジ	パイプ支エ(小)止ネジ	3
9	37430	Oil Tube (70 mm)	ビニールパイプ(70ミリ)	ビニールパイプ(70ミリ)	1
10	7667	Oil Tube Fitting End Bolt (Long)	管継手ボルト(長)	管継手ボルト(長)	1
11	37670	Oil Focal Point (Long)	注油管継手(長)	注油管継手(長)	1
12	37697	Oil Focal Point Cap	注油管継手キャップ	注油管継手キャップ	6
13	37666	Oil Tube Joint Holder	管継手取り付け台	管継手取り付け台	1
14	340	Nut for 37666	ナット	ナット	1
15	9209	Screw for 37666	止ネジ	止ネジ	1
16	37667	Oil Tube Joint Holder Gasket	管継手取り付け台パッキン	管継手取り付け台パッキン	1
17	7666	Oil Tube Fitting End Bolt (Middle)	管継手ボルト(中)	管継手ボルト(中)	2
18	1457	Screw for 37666	止ネジ	止ネジ	2
19	925	Rubber Plug for 37666	詰栓	詰栓	1
20	37671	Oil Focal Point (Short)	注油管継手(短)	注油管継手(短)	1
21	37432	Oil Tube (177 mm)	ビニールパイプ(177ミリ)	ビニールパイプ(177ミリ)	1
22	37676	Oil Tube Holder (Large)	パイプ支エ(大)	パイプ支エ(大)	1
23	4358	Screw for 37676	パイプ支エ(大)止ネジ	パイプ支エ(大)止ネジ	1
24	37691	Oil Tube Joint Ring	管継手リング	管継手リング	1
25	37431	Oil Tube (130 mm)	ビニールパイプ(130ミリ)	ビニールパイプ(130ミリ)	1
26	37659	Oil Pump Gasket	オイルポンプパッキン	オイルポンプパッキン	1
27	37660	Oil Pump Driving Worm Gear	ウォームギヤー	ウォームギヤー	1
28	3410	Screw for 37660	ウォームギヤー止ネジ	ウォームギヤー止ネジ	1
29	37684	Oil Pump Complete Set	ギヤーポンプ(組)	ギヤーポンプ(組)	1
30	7658	Screw for 37684	ギヤーポンプ(組)止ネジ	ギヤーポンプ(組)止ネジ	2
31	38172	Pump Filter Screen Complete Set	ポンプ濾過器(組)	ポンプ濾過器(組)	1
32	38176	Pump Filter Screen Clamp	ポンプ濾過網押エ	ポンプ濾過網押エ	1
33	38175	Pump Filter Screen (Fine Mesh)	ポンプ濾過網(細目)	ポンプ濾過網(細目)	1
34	38174	Pump Filter Screen (Coarse Mesh)	ポンプ濾過網(粗目)	ポンプ濾過網(粗目)	1
35	38173	Pump Filter Case	ポンプ濾過器外枠	ポンプ濾過器外枠	1
36	1208	Screw for 38173	ポンプ濾過器外枠止ネジ	ポンプ濾過器外枠止ネジ	4
37	37685	Oil Cap	オイルカップ	オイルカップ	1
38	566	Washer for 37669	座金	座金	3

11

DCY-103

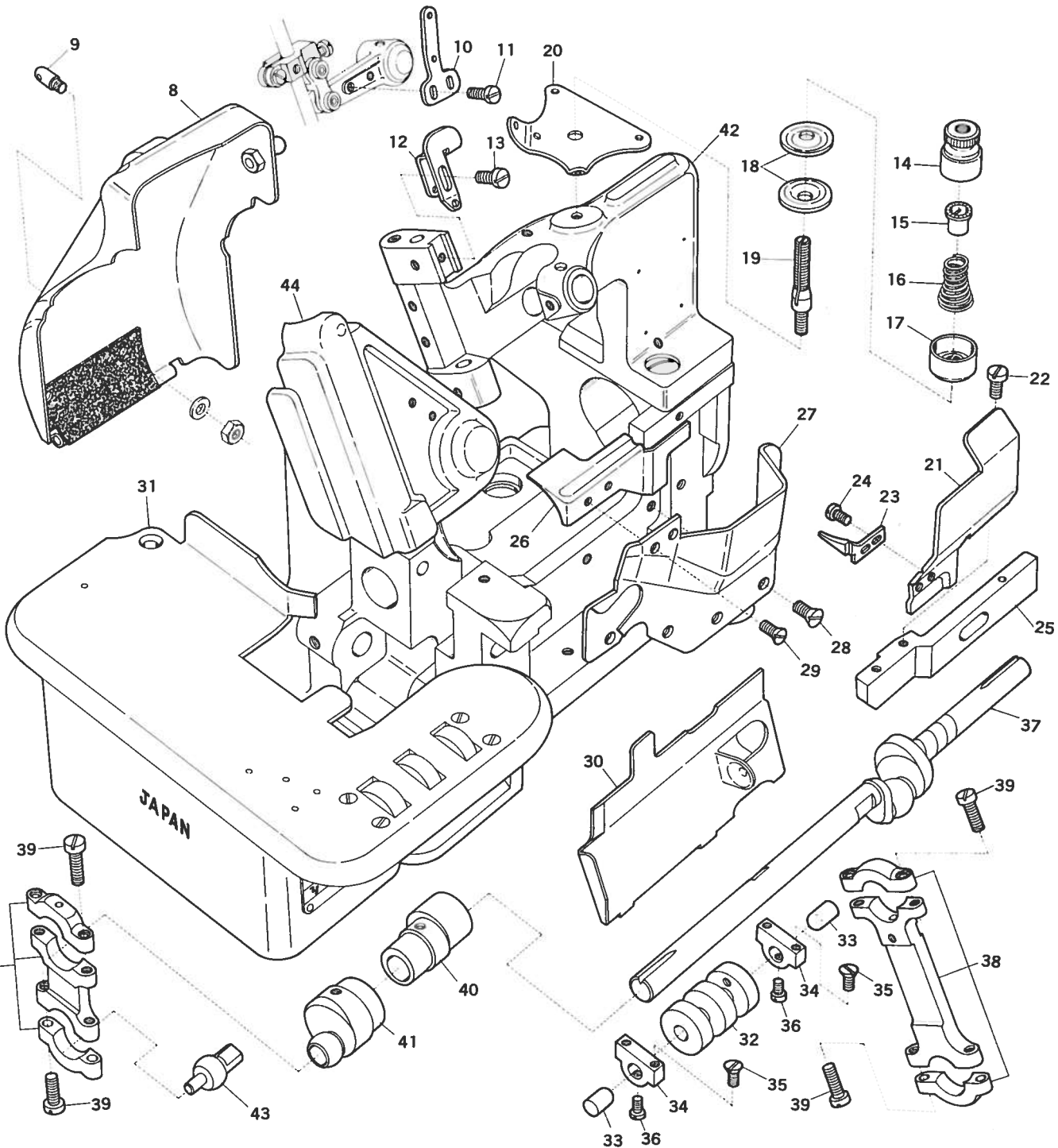
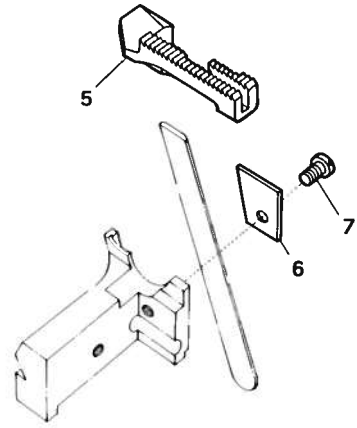
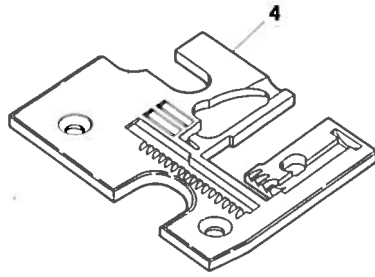
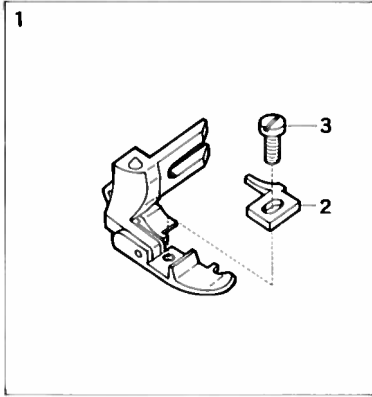

Ref. No.	Parts No.	Description	品 名	Amt. Req.
1	37706	Presser Foot Complete Set	押工(組)	1
2	37163	Presser Foot Stitch Tongue	爪	1
3	1228	Screw for 37163	爪止ネジ	1
4	37702	Throat Plate	針板	1
5	37705	Feed Dog	送り	1
6	37184	Lower Knife Holder Chip Guard	下メス台切り屑除ケ	1
7	4353	Screw for 37184	下メス台切り屑除ケ止ネジ	1
8	37841	Rear Cover (Open) Complete Set	後開キカバー(組)	1
9	38363	Rear Cover Thread Eyelet	後開キカバー糸道	2
10	37060	Needle Thread Swing Eyelet	上糸振り糸道	1
11	1196	Screw for 37060	上糸振り糸道止ネジ	2
12	37262	Needle Thread Eyelete	上糸道	1
13	4358	Screw for 37262	上糸道止ネジ	1
14	37634	Thread Tension Spring Cap	渦巻バネキャップ(上)	1
15	37170	Tension Spring Bushing Complet Set	糸調子ナット廻り止メ(組)	1
16	37632	Upper Looper Thread Tension Spring	渦巻バネ(細)	1
17	37635	Thread Tension Retainer	渦巻バネキャップ(下)	1
18	31111	Tension Disc	調子皿	2
19	1904	Tension Post	調子棒	1
20	37812	Tension Disc Eyelet for Needle Thread	上糸調子台	1
21	37487	Chip Guard	切り屑除ケ	1
22	1175	Screw for 37487	切り屑除ケ止ネジ	2
23	37286	Auxiliary Stitch Tongue	補助爪	1
24	4237	Screw for 37286	補助爪止ネジ	2
25	37466	Chip Guard Holder	角台	1
26	37842	Worm Gear Cover	ウォームカバー	1
27	37805	Front Oil Shield	前カバー	1
28	7619	Screw for 37805	前カバー止ネジ	5
29	1613	Screw for 37842	ウォームカバー止ネジ	2
30	37460	Front Cover	前開キカバー	1
31	37495	Cloth Plate Complete Set	大カバー(組)	1
32	37452	Roller	ローラー	1
33	37453	Roller Holder	ローラー受ケ	2
34	37809	Roller Holder Bracket	ローラー受ケ台	2
35	5345	Screw for 37809	ローラー受ケ台止ネジ	4
36	3433	Screw for 37453	ローラー受ケ止ネジ	2
37	37799	Main Crankshaft	クランクシャフト	1
38	37057	Needle Bar Connecting Rod	大ロット(組)	1
39	7311	Screw for 37057	大ロット・小ロット(組)止ネジ	8
40	37462	Feed Lift and Upper Knife Driving Eccentric	両エキセン	1
41	37831	Looper Driving Eccentric Shaft	エキセンクランク	1
42	37843	Looper Connecting Rod	小ロット(組)	1
43	37058	Driving Lever Ball Stud	球	1
44	37489	Needle Bar Cover	針棒カバー	1

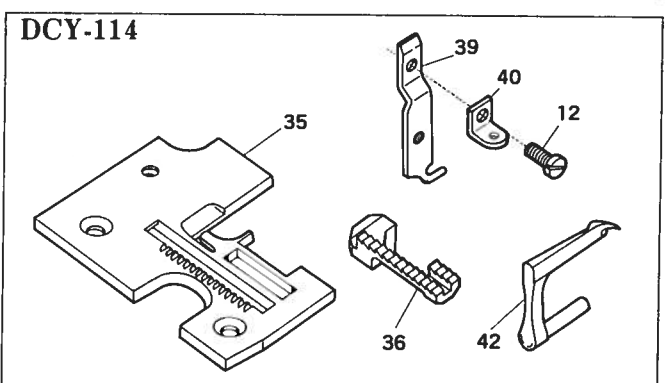
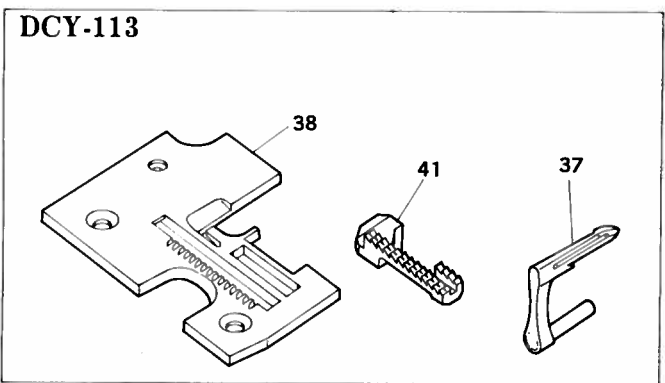
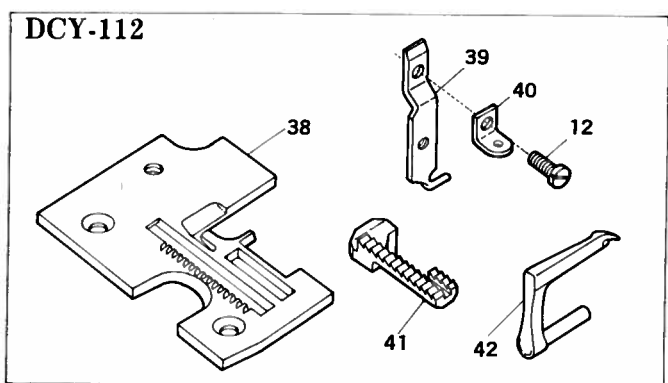
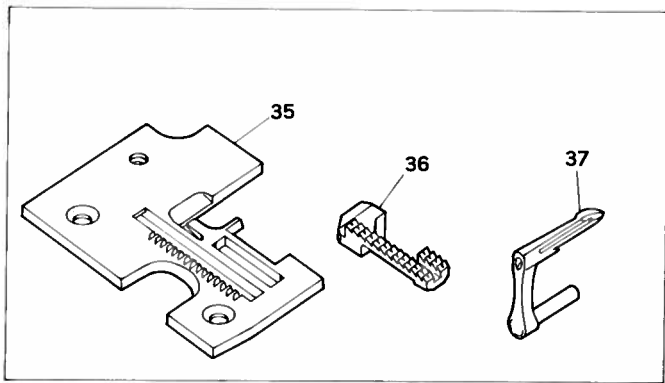
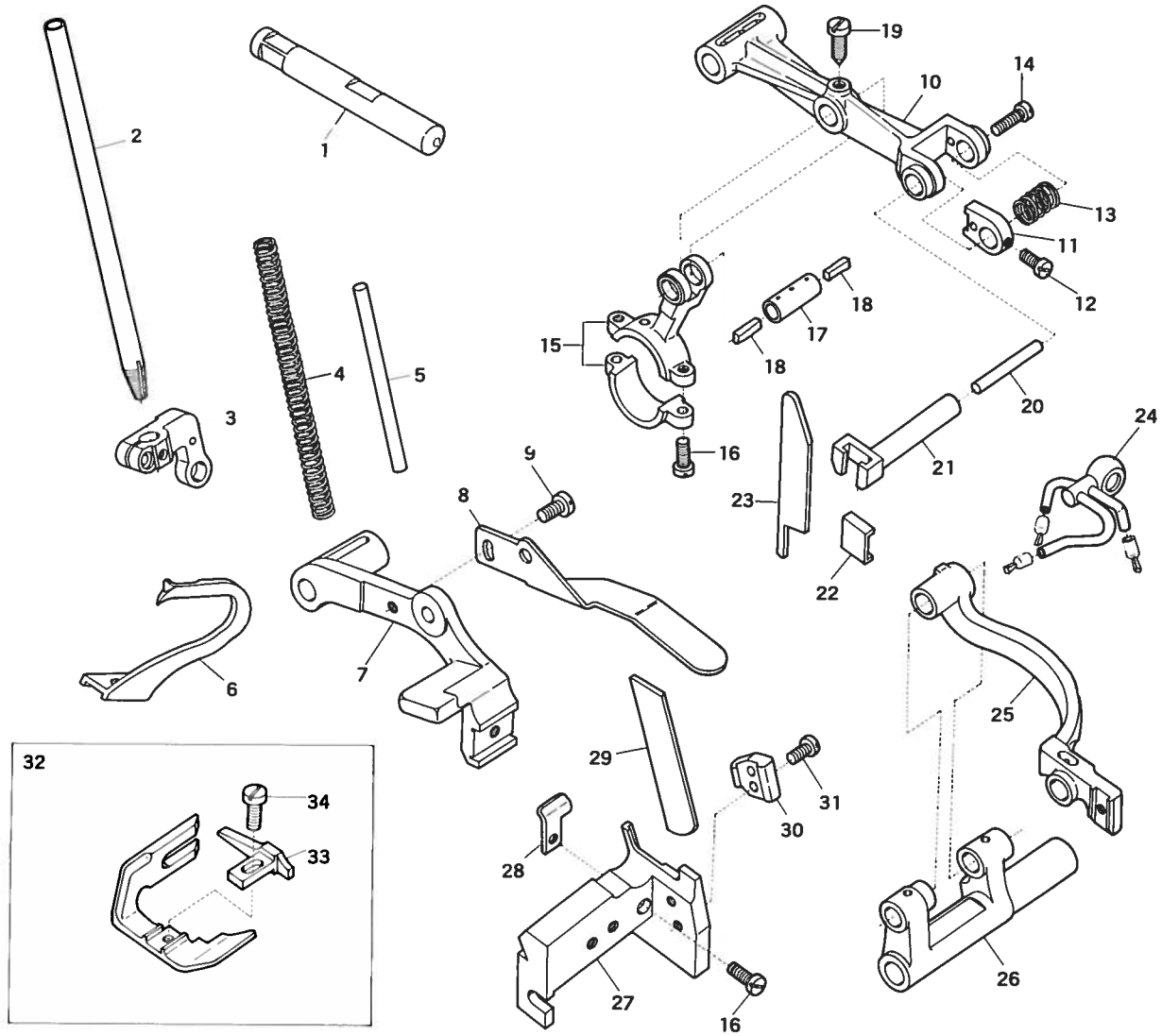

Ref. No.	Parts No.	Description	品名	Amt. Req.
1	37059	Needle Bar Driving Crankshaft	針棒クランク軸	1
2	37062	Needle Bar	針棒	1
3	37818	Needle Bar Connecting Bracket	針棒抱キ	1
4	37065	Presser Spring	押エバネ	1
5	37048	Presser Foot Positioning Pin	押エバネガイドピン	1
6	37271	Upper Looper	大ルーバー	1
7	37064	Presser Arm	押エ台	1
8	37886	Auxiliary Foot Lifter Hand Lever	補助手揚ゲ	1
9	4358	Screw for 37886	補助手揚ゲ止ネジ	1
10	37467	Upper Knife Driving Arm Stud	上メス台	1
11	37478	Upper Knife Holder Guide	上メス案内	1
12	1222	Screw for 37478, 37320	止ネジ	2
13	30413	Upper Knife Holder Spring	上メスバネ	1
14	1132	Screw for 37469	上メス止ネジ	1
15	37883	Upper Knife Driving Connecting Rod	上メスロット(組)	1
16	1174	Screw for 37883	上メスロット(組)止ネジ	2
17	37876	Upper Knife Driving Connecting Rod Pin	上メスロットピン	1
18	296	Felt for 37876	油芯	2
19	1176	Screw for 37876	上メスロットピン止ネジ	1
20	37475	Upper Knife Clamp Pin	上メス押シピン	1
21	37470	Upper Knife Holder	上メス抱キ	1
22	37471	Upper Knife Clamp	上メス押エ	1
23	37469	Upper Knife	上メス	1
24	37479	Oil Focal Point (Short)	注油管継手(短)	1
25	37279	Plain Feed Dog Holder	送り取り付ケ台	1
26	37256	Differential Feed Rocker	送りロックシャフト	1
27	37473	Lower Knife Holder	下メス台	1
28	37458	Needle Guard	針受ケ	1
29	37472	Lower Knife	下メス	1
30	37474	Lower Knife Clamp	下メス押エ	1
31	7405	Screw for 37474	下メス押エ止ネジ	1
32	37496	Presser Foot Complete Set	押エ(組)	1
33	37268	Presser Foot Stitch Tongue	爪	1
34	4236	Screw for 37268	爪止ネジ	1
35	37483	Throat Plate	針板	1
36	37273	Plain Feed Dog	大送り	1
37	37272	Lower Looper	小ルーバー	1
38	37322	Throat Plate	針板	1
39	37319	Needle Bar Thread Retainer Bracket	小調子台	1
40	37320	Auxiliary Thread Eyelet	小調子台補助糸道	1
41	37290	Plain Feed Dog	大送り	1
42	37288	Lower Looper	小ルーバー	1

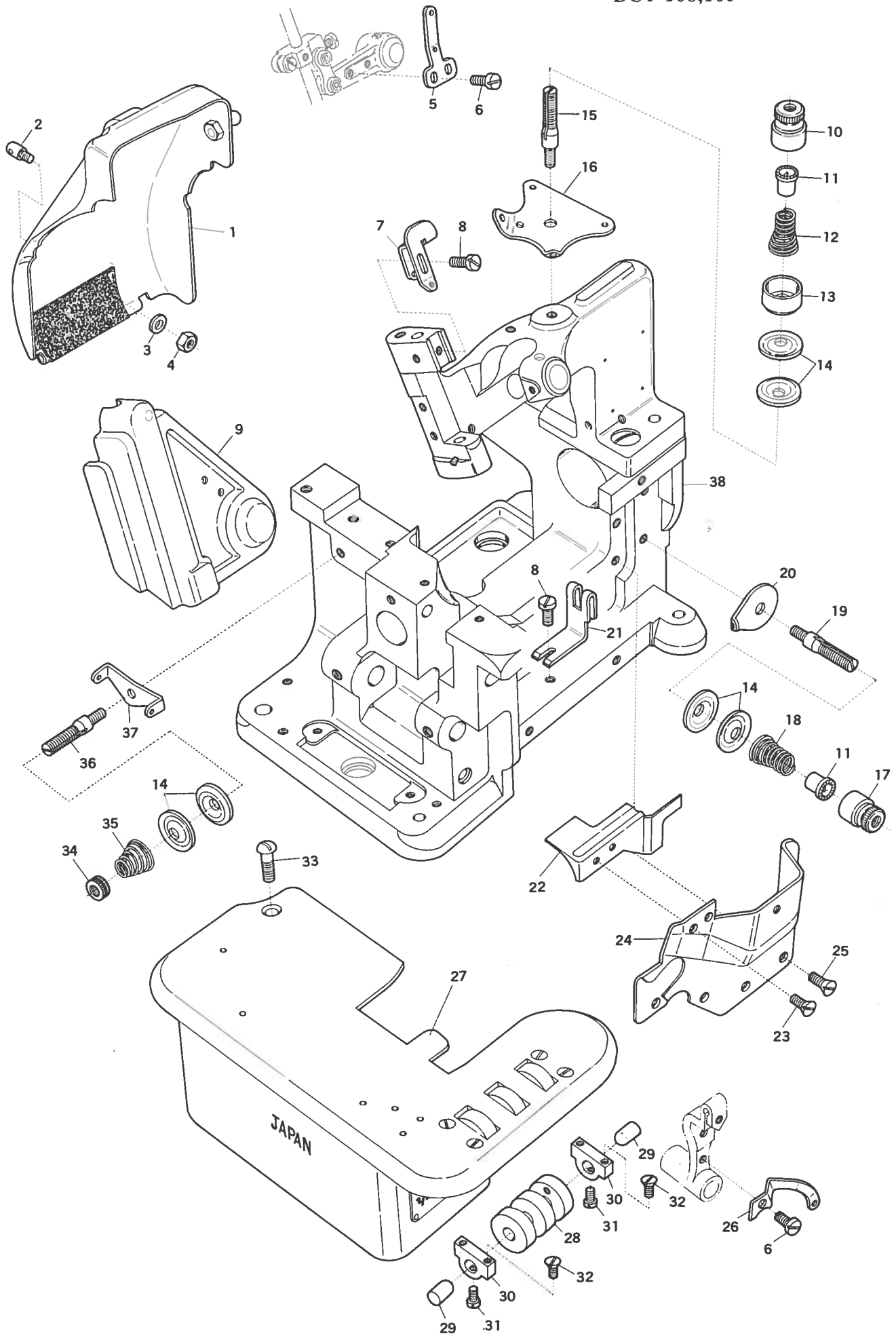

Ref. No.	Parts No.	Description	品名	Amt. Req.
1	37841	Rear Cover(Open) Complete Set	後開キカバー(組)	1
2	38363	Rear Cover Thread Eyelet	後開キカバー糸道	2
3	444	Washer for 38363	座金	2
4	330	Nut for 38363	ナット	2
5	37060	Needle Thread Swing Eyelet	上糸振り糸道	1
6	1196	Screw for 37060, 37833	止ネジ	3
7	37262	Needle Thread Eyelet	上糸道	1
8	4358	Screw for 37262, 37814	止ネジ	2
9	37804	Needle Bar Cover	針棒カバー	1
10	37634	Thread Tension Spring Cap	渦巻バネキャップ(上)	1
11	37170	Tension Spring Bushing	糸調子ナット廻り止メ	2
12	37633	Needle Thread Tension Spring	渦巻バネ(太)	1
13	37635	Thread Tension Retainer	渦巻バネキャップ(下)	1
14	31111	Tension Disc	糸調子皿	6
15	7904	Tension Post	糸調子棒	1
16	37812	Tension Disc Eyelet for Needle Thread	上糸調子台	1
17	37636	Thread Tension Spring Cap	渦巻バネキャップ(小)	1
18	37632	Upper Looper Thread Tension Spring	渦巻バネ(細)	1
19	7817	Tension Post	糸調子棒	1
20	37813	Tension Disc Eyelet for Upper Looper	前糸調子台	1
21	37814	Front Looper Thread Take-up Eyelet	二又糸道	1
22	37842	Front Oil Shield(Upper)	ウォームカバー	1
23	1613	Screw for 37842	ウォームカバー止ネジ	2
24	37805	Front Oil Shield(Lower)	前カバー	1
25	7619	Screw for 37805	前カバー止ネジ	5
26	3783	Upper Looper Thead Pull-off	大ルーバー糸引き	1
27	37834	Cloth Plate Complete Set	大カバー(組)	1
28	37452	Roller	ローラー	1
29	37453	Roller Holder	ローラー受け	2
30	37809	Roller Bracket	ローラー受け台	2
31	3433	Screw for 37453	ローラー受け止ネジ	2
32	5345	Screw for 37809	ローラー受け台止ネジ	4
33	2419	Screw for 37834	大カバー(組)止ネジ	1
34	56	Adjusting Nut	調節ツマミ	1
35	37113	Looper Thread Tension Spring	渦巻バネ(極細)	1
36	1817	Tension Post	糸調子棒	1
37	38074	Tension Disc Eyelet for Looper Thread	ルーバー糸道	1

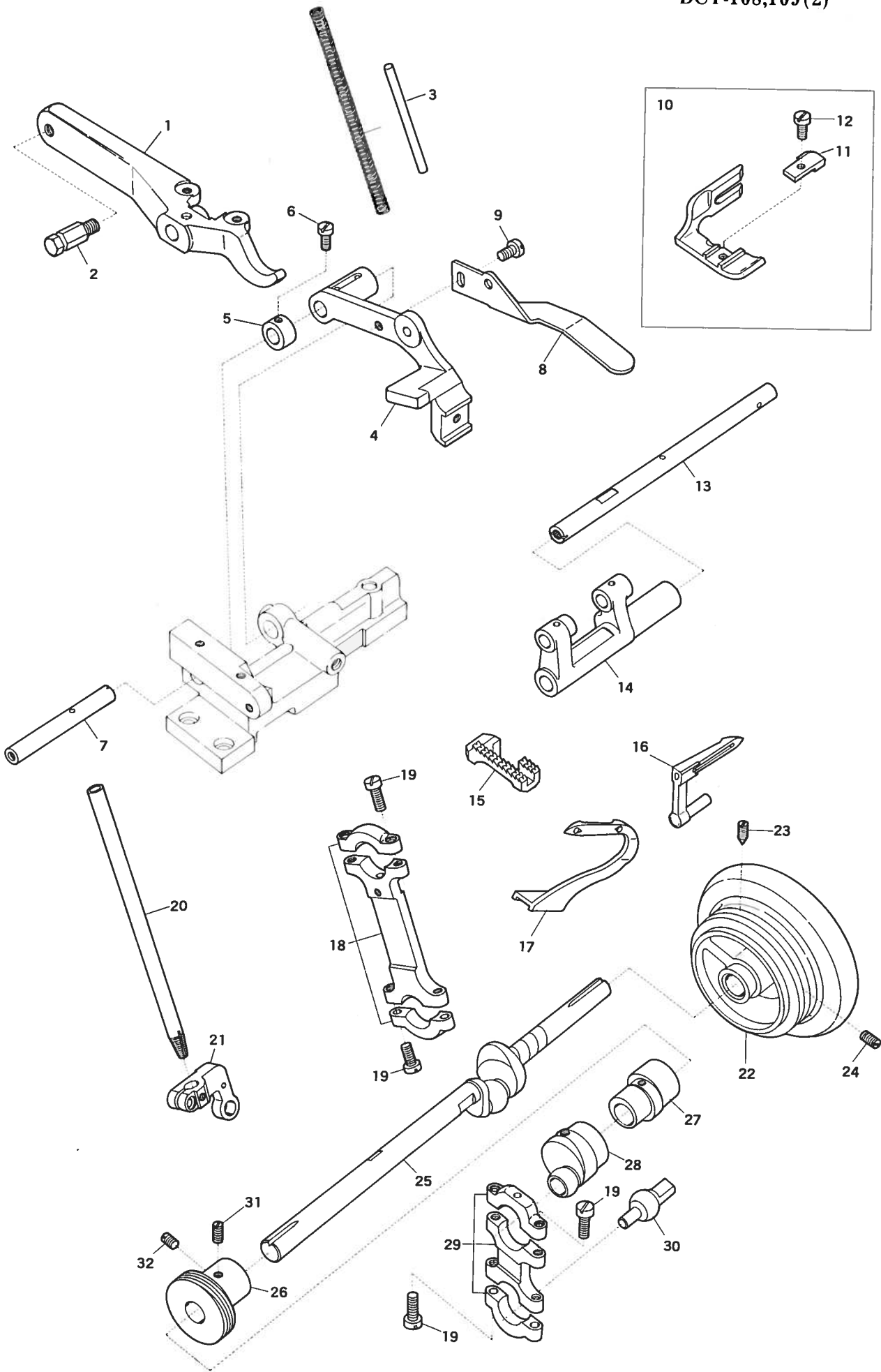

Ref. No.	Parts No.	Description	品 名	Amt. Req.
1	37755	Foot Lifter Lever	押工足揚ゲ	1
2	37757	Chain Latch Bolt	鎖掛ケホルト	1
3	37048	Presser Foot Positioning Pin	押エハネガイドピン	1
4	37064	Presser Arm	押工台	1
5	37827	Presser Arm Hinge Stud Collar	押工台ピンカラー	1
6	1208	Screw for 37827	押工台ピンカラー止ネジ	1
7	37826	Presser Arm Hinge Stud	押工台ピン	1
8	37886	Auxiliary Foot Lifter Hand Lever	補助手揚ゲ	1
9	4358	Screw for 37886	補助手揚ゲ止ネジ	1
10	37848	Presser Foot Complete Set	押工(組)	1
11	37850	Presser Foot Stitch Tongue	爪	1
12	1228	Screw for 37850	爪止ネジ	1
13	37835	Feed Bar Shaft	送り台シャフト	1
14	37256	Differential Feed Rocker	送りロックシャフト	1
15	37439	Plain Feed Dog	送り	1
16	37076	Lower Looper	小ルーバー	1
17	37832	Upper Looper	大ルーバー	1
18	37057	Needle Bar Connecting Rod	大ロット(組)	1
19	7311	Screw for 37057, 37843	止ネジ	8
20	37062	Needle Bar	針棒	1
21	37818	Needle Bar Connecting Bracket	針棒抱キ	1
22	37816	Pully	プーリー	1
23	2347	Screw for 37816	プーリー止ネジ	1
24	1419	Screw for 37816	プーリー止ネジ	1
25	37799	Main Crankshaft	クランクシャフト	1
26	37438	Feed Driving Eccentric	片エキセン	1
27	37437	Feed Lift and Upper Knife Driving Eccentric	両エキセン	1
28	37831	Looper Driving Eccentric Shaft	エキセンクランク	1
29	37843	Looper Connecting Rod	小ロット(組)	1
30	37058	Driving Lever Ball Stud	球(穴ナシ)	1
31	7650	Screw for 37438	片エキセン止ネジ	1
32	3433	Screw for 37438	片エキセン止ネジ	1

15

DCY-108

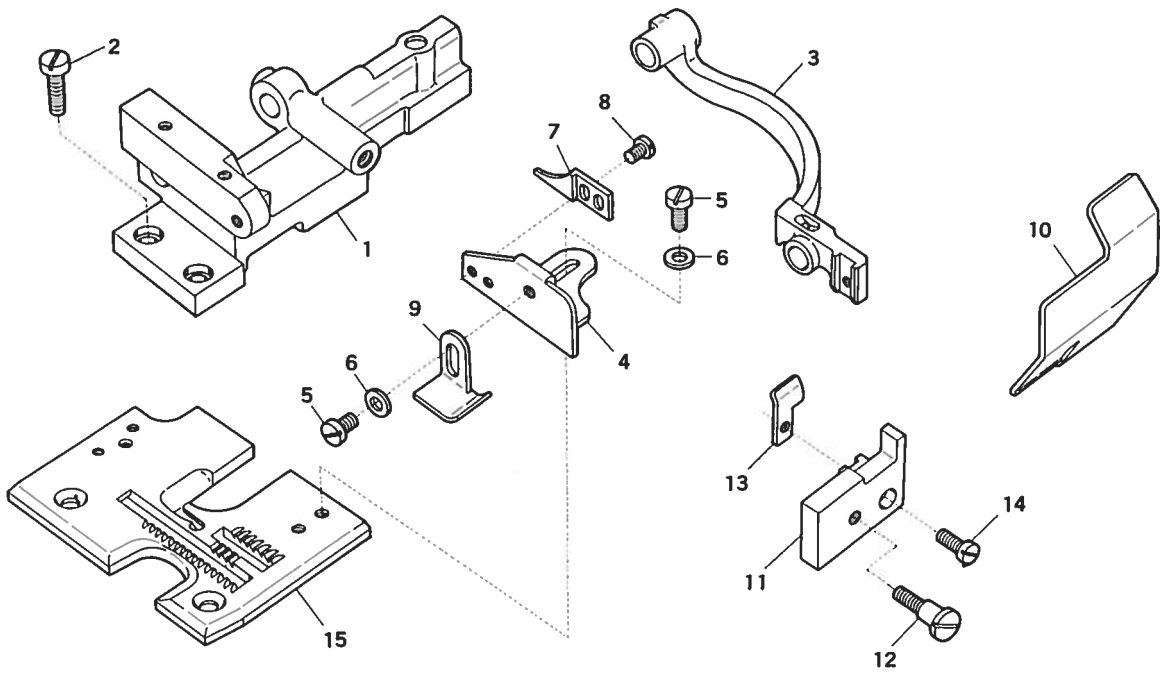

DCY-109

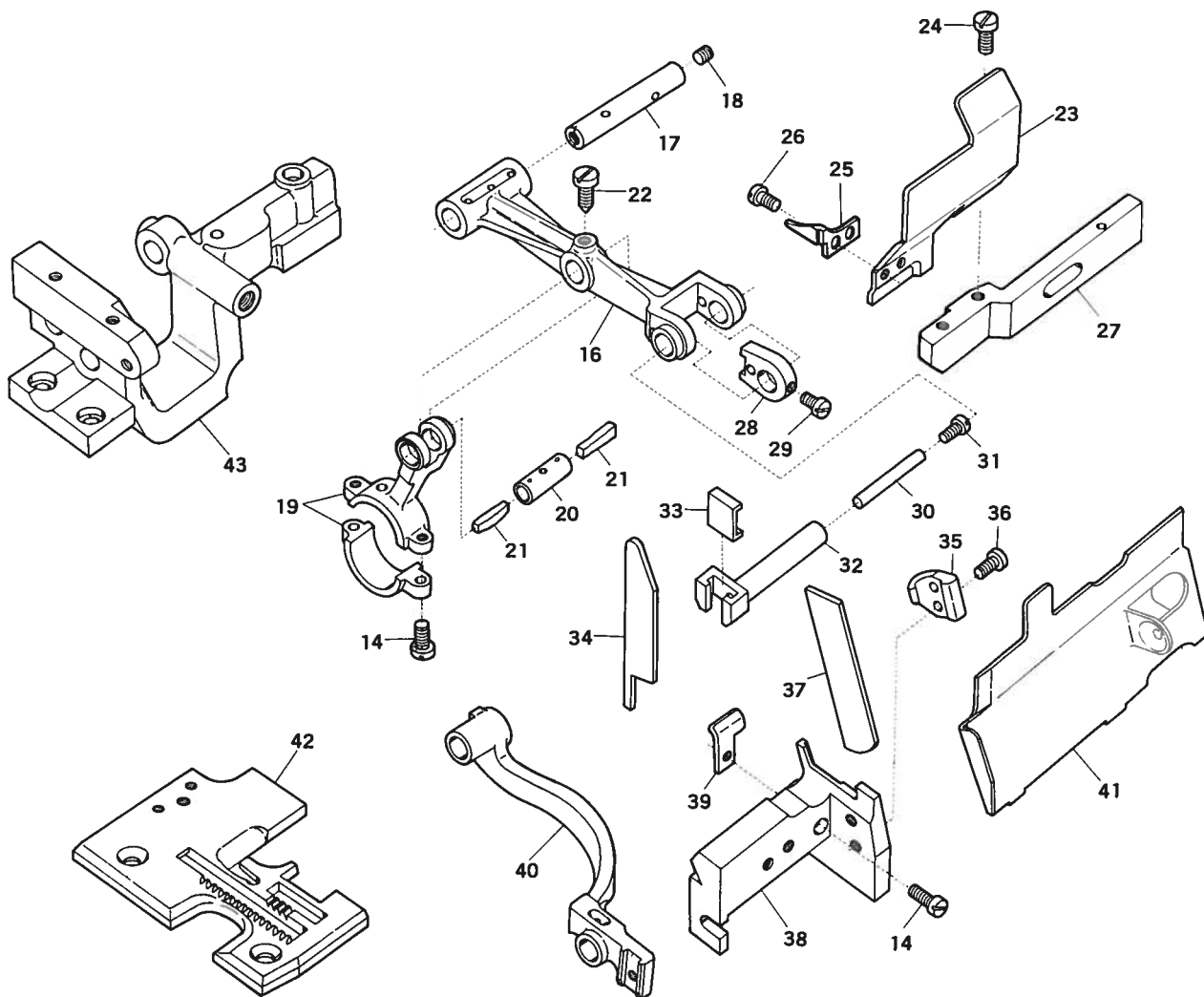

Ref. No.	Parts No.	Description	品名	Amt. Req.
1	37825	Foot Lifter Device Bracket	押工揚げ装置台	1
2	1156	Screw for 37825	押工揚げ装置止ネジ	2
3	37257	Feed Dog Holder	送り取り付ケ台	1
4	37821	Edge Guide	定規	1
5	1202	Screw for 37821, 37822	止ネジ	3
6	532	Washer for 37821, 37822	座金	3
7	37823	Auxiliary Stitch Tongue	補助爪	1
8	1228	Screw for 37823	補助爪止ネジ	2
9	37822	Fabric Guard	布滑り案内	1
10	37811	Chip Guard	切屑除ケ	1
11	37824	Needle Guard Bracket	針受ケ台	1
12	2086	Screw for 37824	針受ケ台止ネジ	1
13	37845	Needle Guard	針受ケ	1
14	1174	Screw for 37845	針受ケ止ネジ	1
15	37800	Throat Plate	針板	1
16	47407	Upper Knife Driving Arm Stud	上メス台	1
17	37468	Upper Knife Driving Arm Stud Pin	上メス台ピン	1
18	7650	Screw for 37468	上メス台ピン止ネジ	1
19	37883	Upper Knife Driving Connecting Rod	上メスロット	1
20	37876	Upper Knife Driving Connecting Rod Pin	上メスロットピン	1
21	290	Felt for 37876	油芯	2
22	1176	Screw for 37876	上メスロットピン止ネジ	1
23	37461	Chip Guard	切屑除ケ	1
24	1175	Screw for 37461	切屑除ケ止ネジ	2
25	37464	Auxiliary Stitch Tongue	補助爪	1
26	4237	Screw for 37464	補助爪止ネジ	2
27	37466	Chip Guard Holder	角台	1
28	37478	Upper Knife Holder Guard	上メス案内	1
29	1222	Screw for 37478	上メス案内止ネジ	1
30	37475	Upper Knife Clamp Pin	上メス押エピン	1
31	1132	Screw for 37469	上メス止ネジ	1
32	37470	Upper Knife Holder	上メス抱キ	1
33	37471	Upper Knife Clamp	上メス押シ	1
34	37469	Upper Knife	上メス	1
35	37474	Lower Knife Clamp	下メス押工	1
36	7405	Screw for 37474	下メス押工止ネジ	2
37	37472	Lower Knife	下メス	1
38	37473	Lower Knife Holder	下メス台	1
39	37477	Needle Guard	針受ケ	1
40	37279	Feed Dog Holder	送り取り付ケ台	1
41	37460	Front Cover	前開キカバー	1
42	37463	Throat Plate	針板	1
43	37465	Foot Lifter Device Bracket	押工揚げ装置台	1

Ref. No.	Parts No.	Description	品名	Amt. Req.
1	37669	Oil Tube Fitting One Way End	片口管継手	3
2	567	Washer for 37668, 37669, 37691, 37715	座金	9
3	566	Washer for 37669, 37691	座金	3
4	7668	Oil Tube Fitting End Bolt(Short)	管継手ボルト(短)	4
5	37675	Oil Tube Clamp	緊束環	8
6	37432	Oil Tube (177mm) DCY-108	ビニールパイプ(177ミリ)	1
6-1	37433	Oil Tube (217mm) DCY-109	ビニールパイプ(217ミリ)	1
7	37668	Oil Tube Fitting Two Way End	両口管継手	2
8	37431	Oil Tube (130mm) DCY-108	ビニールパイプ(130ミリ)	1
8-1	37435	Oil Tube (120mm) DCY-109	ビニールパイプ(120ミリ)	1
9	6762	Oil Tube Fitting End Bolt	管継手ボルト	1
10	1457	Screw for Oil Tube Joint Holder	止ネジ	2
11	925	Rubber Plug for Oil Tube Joint Holder	詰栓	1
12	37667	Oil Tube Joint Holder Gasket	管継手取り付け台パッキン	1
13	37715	Oil Focal Point (Short)	注油管継手(短)	1
14	37697	Oil Focal Point Cap	注油管継手キャップ	2
15	37433	Oil Tube (217mm) DCY-108	ビニールパイプ(217ミリ)	1
15-1	37481	Oil Tube (225mm) DCY-109	ビニールパイプ(225ミリ)	1
16	7666	Oil Tube Fitting End Bolt (Middle)	管継手ボルト(中)	1
17	37691	Oil Tube Joint Ring	管継手リング	1
18	37435	Oil Tube (120mm) DCY-108	ビニールパイプ(120ミリ)	1
18-1	37431	Oil Tube (130mm) DCY-109	ビニールパイプ(130ミリ)	1
19	37677	Oil Tube Holder (Small)	パイプ支エ(小)	2
20	1196	Screw for 37677	パイプ支エ(小)止ネジ	2
21	37880	Oil Tube Holder (Large)	パイプ支エ(大)	1
22	4358	Screw for 37880	パイプ支エ(大)止ネジ	1
23	37659	Oil Pump Gasket	オイルポンパッキン	1
24	37660	Oil Pump Driving Worm Gear	ウォームギヤー	1
25	3410	Screw for 37660	ウォームギヤー止ネジ	1
26	37684	Oil Pump Complete Set	ギヤーポンプ(組)	1
27	7658	Screw for 37684	ギヤーポンプ(組)止ネジ	2
28	38172	Pump Filter Screen Complete Set	ポンプろ過器(組)	1
29	38176	Pump Filter Screen Clamp	ポンプろ過網押工	1
30	38175	Pump Filter Screen (Fine Mesh)	ポンプろ過網(細目)	1
31	38174	Pump Filter Screen (Coarse Mesh)	ポンプろ過網(粗目)	1
32	38173	Pump Filter Case	ポンプろ過器外枠	1
33	1208	Screw for 38173	ポンプろ過器外枠止ネジ	4
34	37685	Oil Cap	オイルカップ	1

DCY-120

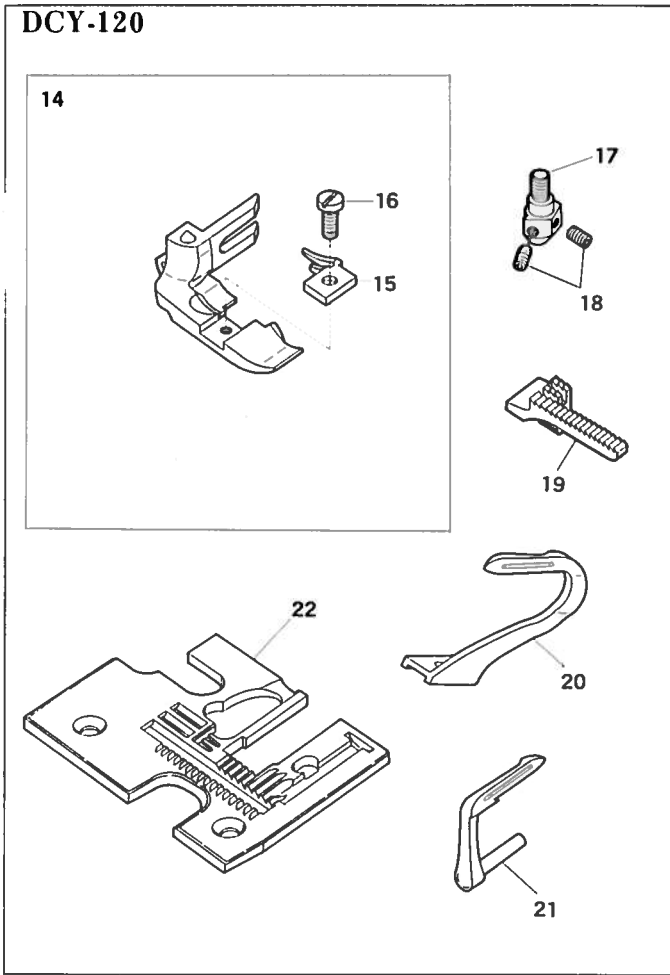

DCY-120,120W,121

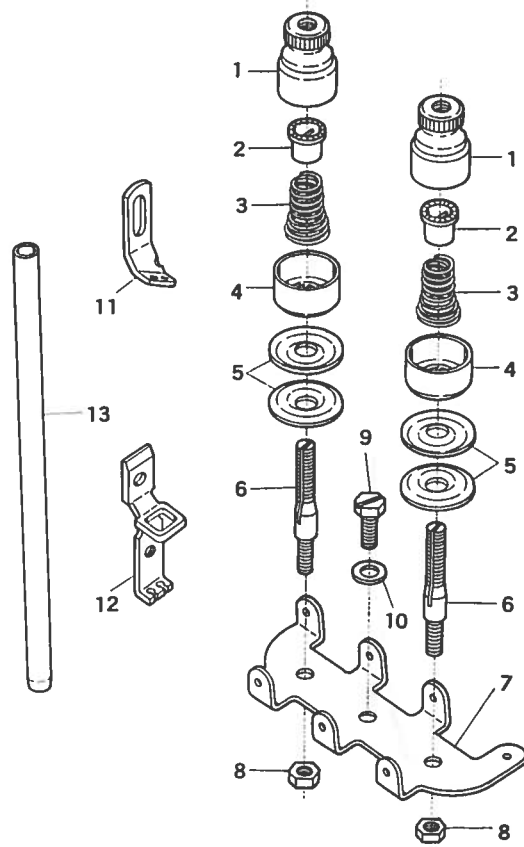

DCY-120W

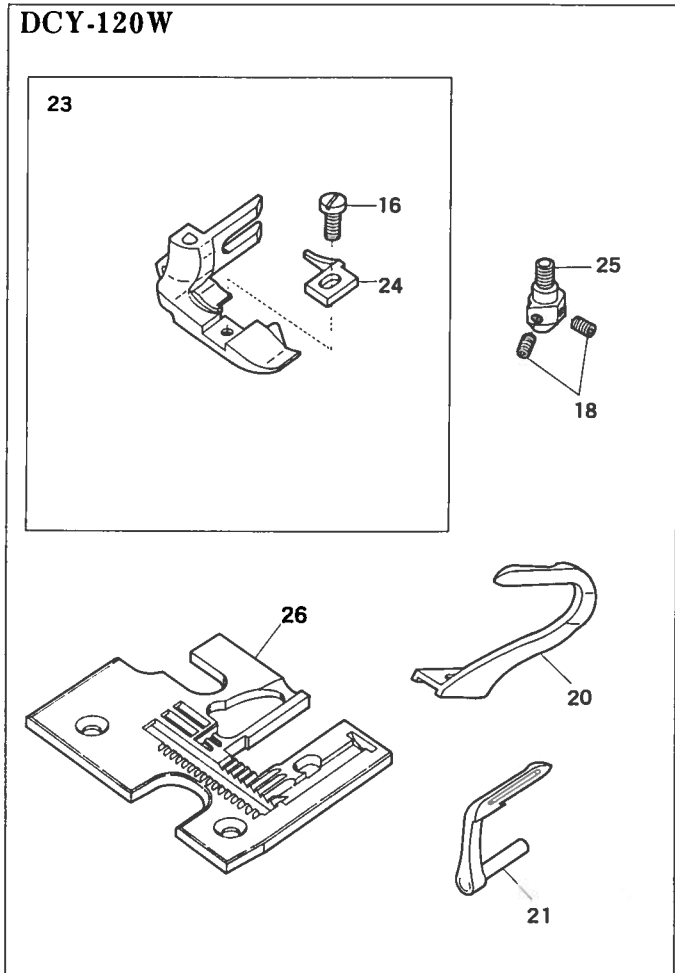

DCY-121

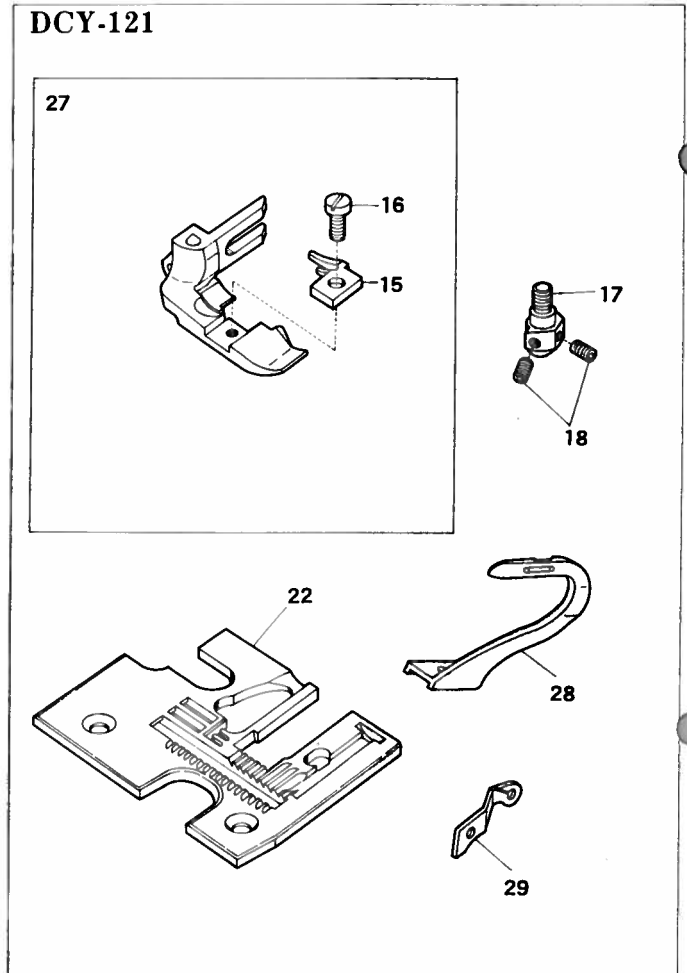

Ref. No.	Parts No.	Description	品名	Amt. Req.
1	37634	Thread Tension Spring Cap	渦巻バネキャップ(上)	2
2	37170	Tension Spring Bushing	糸調子ナット廻り止メ	2
3	37633	Needle Thread Tension Spring	渦巻バネ(太)	2
4	37635	Thread Tension Retainer	渦巻バネキャップ(下)	2
5	31111	Tension Disc	調子皿	4
6	7904	Tension Post	糸調子棒	2
7	37369	Tension Disc Eyelet for Needle Thread	上糸調子台	1
8	340	Nut for 7904	ナット	2
9	2308	Screw for 37369	上糸調子台止ネジ	1
10	554	Washer for 37369	座金	1
11	37368	Needle Thread Eyelet	上糸道	1
12	37370	Needle Bar Thread Retainer Bracket	小調子台	1
13	37372	Needle Bar	針棒	1
14	37734	Presser Foot Complete Set	押工(組)	1
15	37376	Presser Foot Stitch Tongue	爪	1
16	1228	Screw for 37376	爪止ネジ	1
17	37373	Needle Holder	針止	1
18	3637	Screw for 37373, 37894	針止止ネジ	2
19	37249	Plain Feed Dog (DCY-120-1)	一枚送り	1
20	37378	Upper Looper	大ルーバー	1
21	37379	Lower Looper	小ルーバー	1
22	37732	Throat Plate	針板	1
23	37396	Presser Foot Complete Set	押工(組)	1
24	37397	Presser Foot Stitch Tongue	爪	1
25	37894	Needle Holder	針止	1
26	37139	Throat Plate	針板	1
27	37734	Presser Foot Complete Set	押工(組)	1
28	37382	Upper Looper	大ルーバー	1
29	37383	Upper Looper Thread Pull-off	大ルーバー糸引き	1

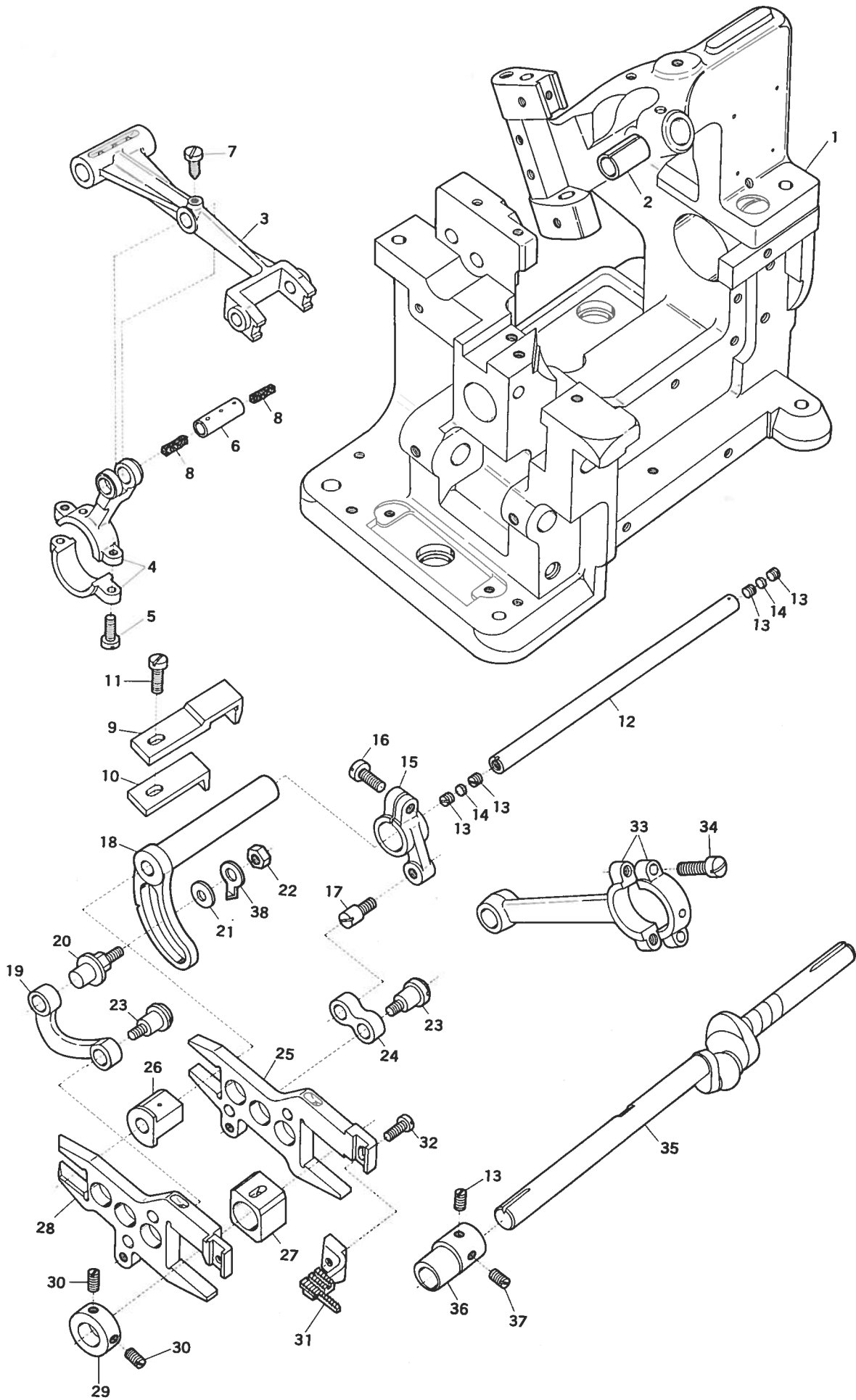

Ref. No.	Parts No.	Description	品名	Amt. Req.
1	37851	Machine Frame	アームベット(組)	1
2	37858	Feed Bar Shaft Bushing (Right)	割ブッシュ(短)	1
3	37877	Upper Knife Driving Arm Stud	上メス台	1
4	37883	Upper Knife Driving Connecting Rod	上メスロット(組)	1
5	1174	Screw for 37883	上メスロット(組)止ネジ	2
6	37876	Upper Knife Driving Connecting Rod Pin	上メスロットピン	1
7	1176	Screw for 37866	上メスロットピン止ネジ	1
8	290	Felt for 37876	油芯	2
9	37873	Feed Bar Guide (Right)	送り取り付ケ台案内(上)	1
10	37874	Feed Bar Guide (Left)	送り取り付ケ台案内(下)	1
11	5046	Screw for 37873, 37874	送り取り付ケ台案内止ネジ	1
12	37857	Feed Bar Shaft	送り台シャフト	1
13	1457	Screw for 37857	止ネジ	5
14	925	Feed Bar Shaft Gasket	パッキン	2
15	37860	Main Feed Bar Driving Lever	送りロックシャフト腕	1
16	1156	Screw for 37860	送りロックシャフト腕止ネジ	1
17	6255	Screw for 37866	後送りリンク止ネジ	1
18	37896	Differential Feed Rocker	送りロックシャフト	1
19	37862	Differential Feed Bar Driving Connection	前送りリンク	1
20	6049	Screw for 37862	前送りリンク止ネジ	1
21	551	Washer for 37862	座金	1
22	346	Nut for 37862	ナット	1
23	6053	Screw for 37862, 37866	止ネジ	2
24	37866	Main Feed Bar Driving Connection	後送りリンク	1
25	37865	Main Feed Bar	後送り台	1
26	38149	Feed Bar Guide Block	角駒(小)	1
27	37869	Feed Lift Block	角駒(大)	1
28	37861	Differential Feed Bar	前送り台	1
29	37870	Feed Lift Block Collar	駒止カラー	1
30	9526	Screw for 37870	駒止カラー止ネジ	2
31	37872	Main Feed Dog	後送り	1
32	1175	Screw for 37872	後送り止ネジ	1
33	37887	Feed Dog Driving Connecting Rod	送りロット(組)	1
34	2043	Screw for 37887	送りロット(組)止ネジ	2
35	37897	Main Crankshaft	クランクシャフト	1
36	37856	Feed Lift and Upper Knife Driving	両エキセン	1
37	3433	Screw for 37856	両エキセン止ネジ	1
38	37864	Driving Connection Stopper	リンクストッパー	1

DCY-200給油

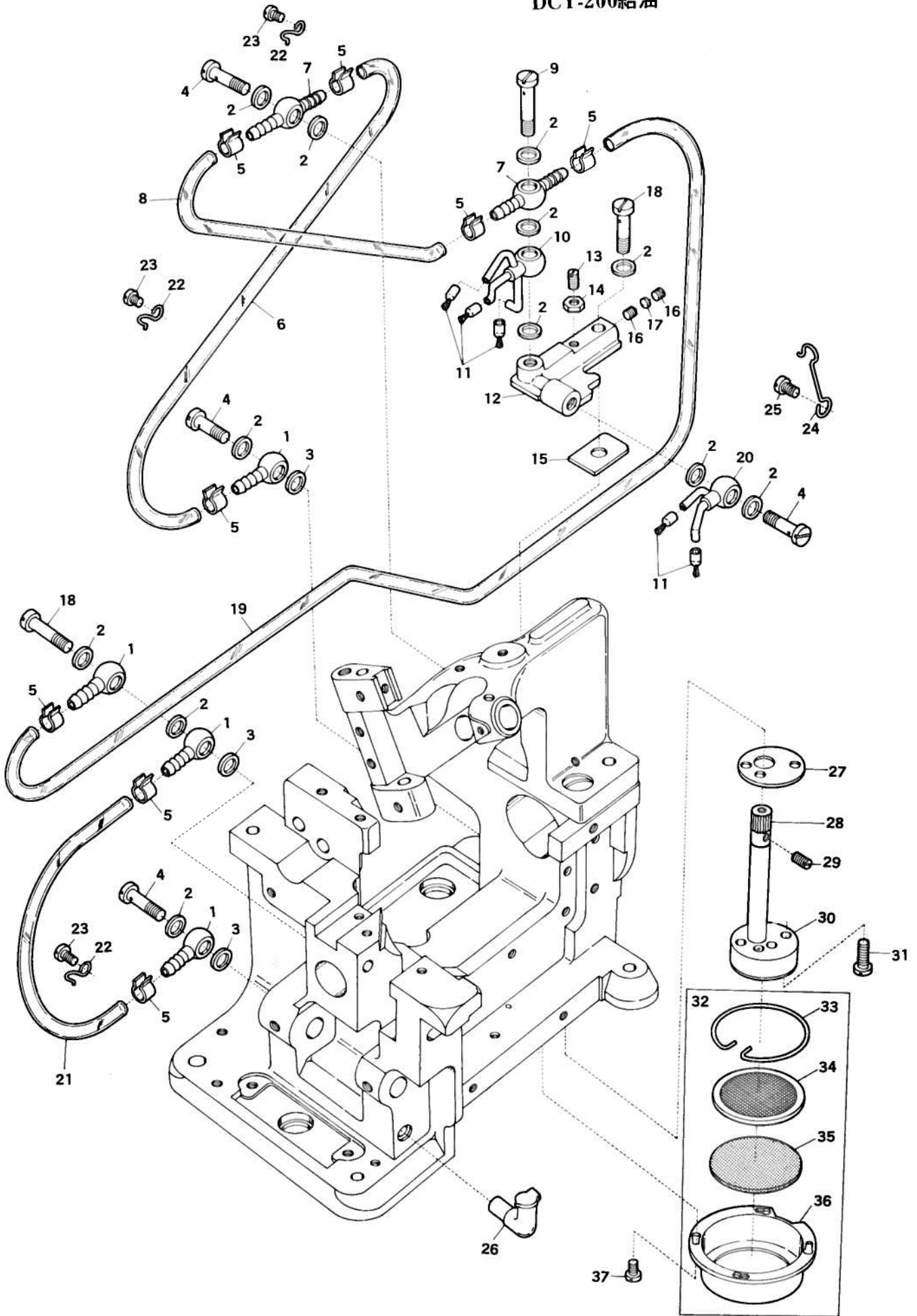

Ref. No.	Parts No.	Description	品名	Amt. Req.
1	37669	Oil Tube Fitting One Way End	片口管継手	3
2	567	Washer for 37666, 37669, 37879	座金	12
3	566	Washer for 37669	座金	3
4	7668	Oil Tube Fitting End Bolt (Short)	管継手ボルト(短)	4
5	37675	Oil Tube Clamp Oil Tube (217mm)	緊束環	8
6	37433	Oil Tube Fitting Two Way End	ビニールパイプ(217ミリ)	1
7	37668	Oil Tube (70mm)	両口管継手	2
8	37430	Oil Tube Fitting End Bolt (Long)	ビニールパイプ(70ミリ)	1
9	7667	Oil Focal Point (Long)	管継手ボルト(長)	1
10	37878	Oil Focal Point (Long)	注油管継手(長)	1
11	37697	Oil Focal Point Cap	注油管継手キャップ	5
12	37666	Oil Tube Joint Holder	管継手取り付ケ台	1
13	9209	Screw for 37666	止ネジ	1
14	340	Nut for 37666	ナット	1
15	37667	Oil Tube Joint Holder Gasket	管継手取り付ケ台パッキン	1
16	1457	Screw for 37666	止ネジ	2
17	925	Rubber Plug for 37666	詰栓	1
18	7666	Oil Tube Fitting End Bolt (Middle)	管継手ボルト(中)	2
19	37890	Oil Tube (333mm)	ビニールパイプ(333ミリ)	1
20	37879	Oil Focal Point (Short)	注油管継手(短)	1
21	37431	Oil Tube (130mm)	ビニールパイプ(130ミリ)	1
22	37677	Oil Tube Holder (Small)	パイプ支エ(小)	3
23	1196	Screw for 37677	パイプ支エ(小)止ネジ	3
24	37676	Oil Tube Holder (Large)	パイプ支エ(大)	1
25	4358	Screw for 37676	パイプ支エ(大)止ネジ	1
26	37685	Oil Cap	オイルカップ	1
27	37659	Oil Pump Gasket	オイルポンプパッキン	1
28	37660	Oil Pump Driving Worm Gear	ウォームギヤー	1
29	3410	Screw for 37660	ウォームギヤー止ネジ	1
20	37684	Oil Pump Complete Set	ギヤーポンプ(組)	1
31	7658	Screw for 37684	ギヤーポンプ(組)止ネジ	2
32	38172	Pump Filter Screen Complete Set	ポンプ濾過器(組)	1
33	38176	Pump Filter Screen Clamp	ポンプ濾過網押え	1
34	38175	Pump Filter Screen (Fine Mesh)	ポンプ濾過網(細目)	1
35	38174	Pump Filter Screen (Coarse Mesh)	ポンプ濾過網(粗目)	1
36	38173	Pump Filter Case	ポンプ濾過器外枠	1
37	1208	Screw for 38173	ポンプ濾過器外枠止ネジ	4

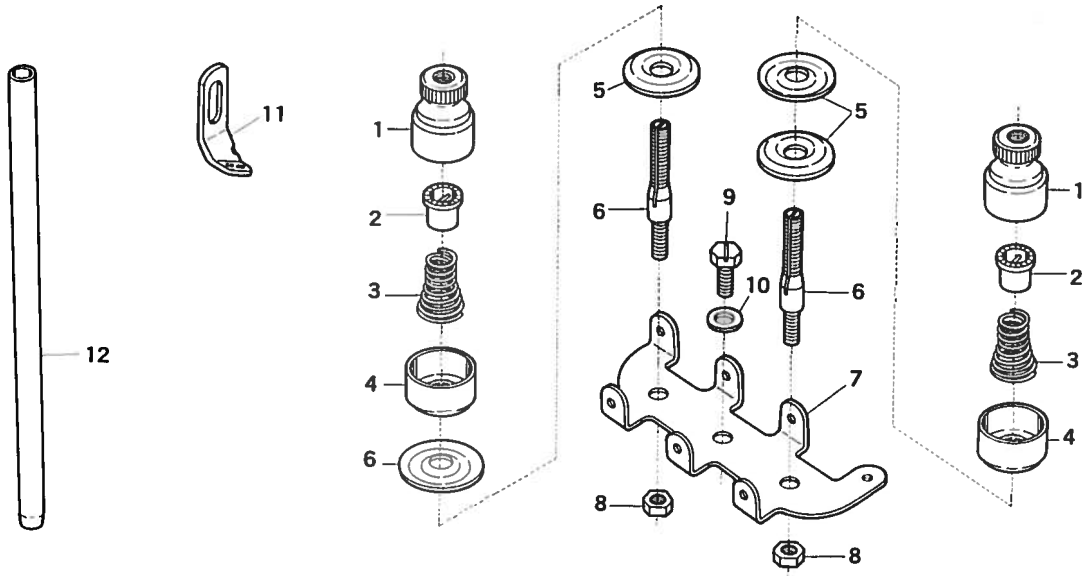

DCY-200

13

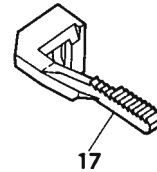
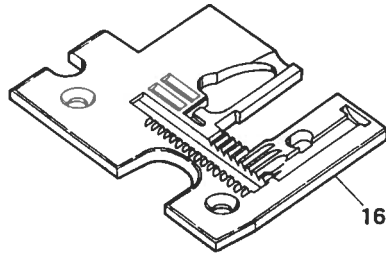
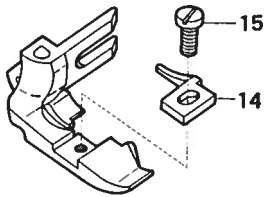

DCY-203

18

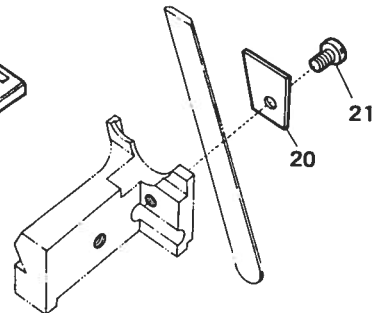
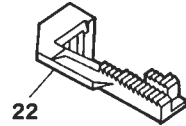
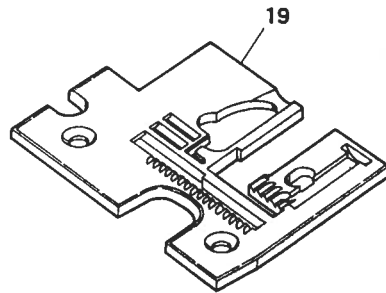
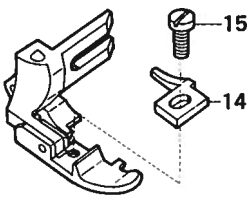

Ref. No.	Parts No.	Description	品名	Amt. Req.
1	37634	Thread Tension Spring Cop	渦巻バネキャップ(上)	2
2	37170	Tension Spring Bushing	糸調子ナット廻り止メ	2
3	37633	Needle Thread Tension Spring	渦巻バネ(太)	2
4	37635	Thread Tension Retainer	渦巻バネキャップ(下)	2
5	31111	Tension Disc	調子皿	4
6	7904	Tension Post	糸調子棒	2
7	37369	Tension Disc Eyelet for Needle Thread	上糸調子台	1
8	340	Nut for 7904	ナット	2
9	2308	Screw for 37369	上調子台止ネジ	1
10	554	Washer for 37369	座金	1
11	37368	Needle Thread Eyelet	上糸道	1
12	37372	Needle Bar	針棒	1
13	37868	Presser Foot Complete Set	押工(組)	1
14	37163	Presser Foot Stitch Tongue	爪	1
15	1228	Screw for 37163	爪止ネジ	1
16	38151	Throat Plate	針板	1
17	37871	Differential Feed Dog	前送り	1
18	37706	Presser Foot Complete Set	押工(組)	1
19	37892	Throat Plate	針板	1
20	37184	Chip Guard	下メス台切り屑除ケ	1
21	4353	Screw for 37184	下メス台切り屑除ケ	1
22	37893	Differential Feed Dog	前送り	1

DCY-220

1

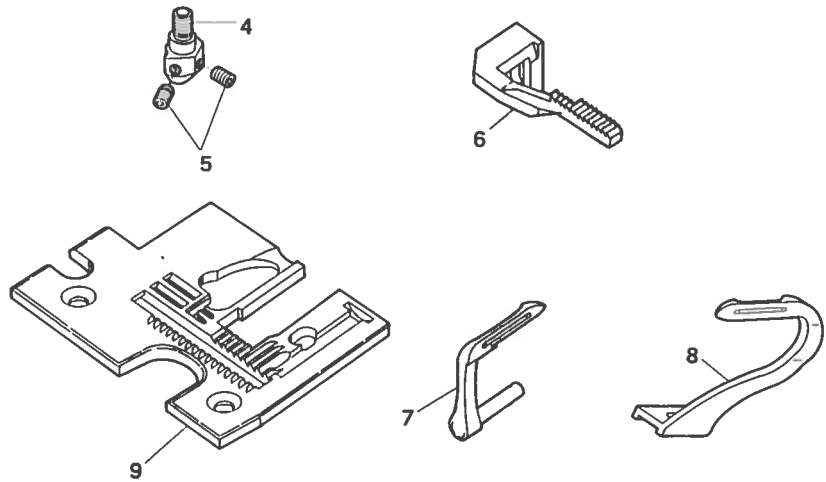
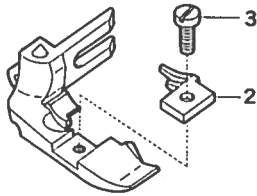

DCY-220W

10

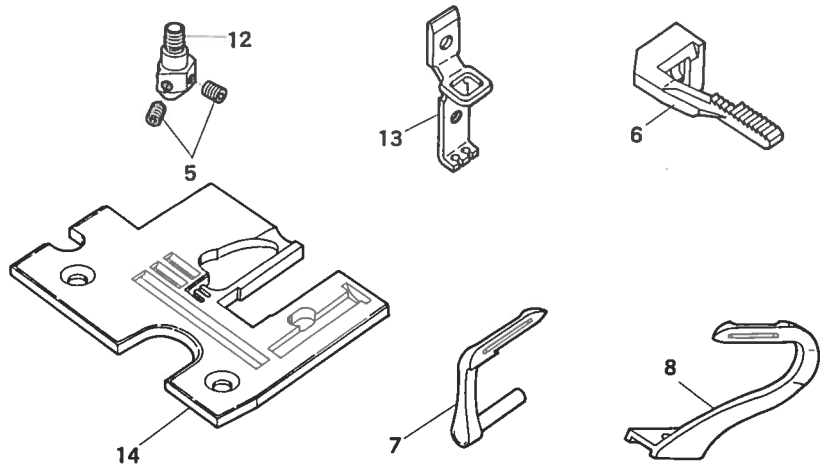
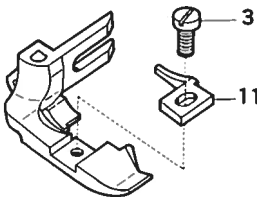

DCY-221

15

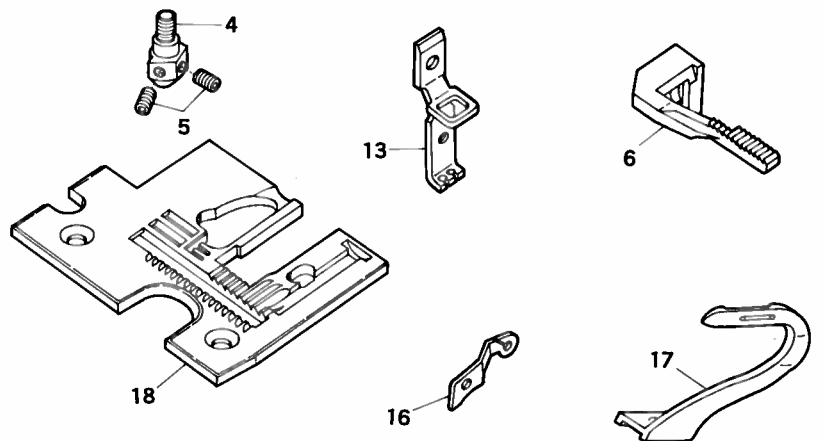
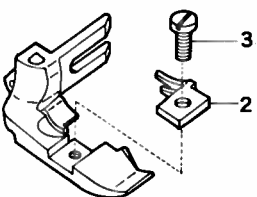

DCY-220,220W,221 EXCLUSIVE PARTS

サブクラス専用部品

21

Ref. No.	Parts No.	Description	品名	Amt. Req.
1	38146	Presser Foot Complete Set	押工(組)	1
2	37376	Presser Foot Stitch Tongue	爪	1
3	1228	Screw for 37376, 37397	爪止ネジ	1
4	37373	Needle Holder	針止	1
5	3637	Screw for 37373, 37894	針止止ネジ	2
6	37871	Differential Feed Dog	前送り	1
7	37379	Lower Looper	小ルーバー	1
8	37378	Upper Looper	大ルーバー	1
9	38142	Throat Plate	針板	1
10	38147	Presser Foot Complete Set	押工(組)	1
11	37397	Presser Foot Stitch Tongue	爪	1
12	37894	Needle Holder	針止	1
13	37370	Needle Bar Thread Retainer Bracket	小調子台	1
14	37899	Throat Plate	針板	1
15	38146	Preeser Foot Complete Set	押工(組)	1
16	37383	Upper Looper Thread Pull-off	大ルーバー糸引き	1
17	37382	Upper Looper	大ルーバー	1
18	38142	Throat Plate	針板	1

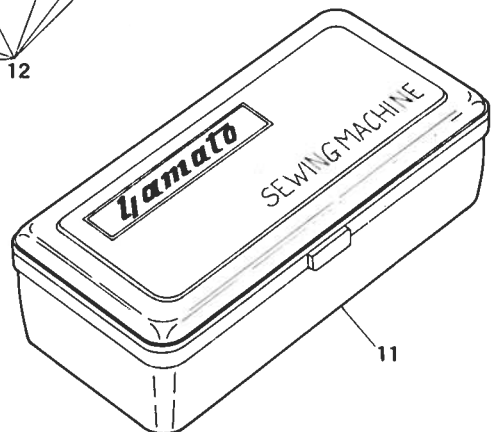
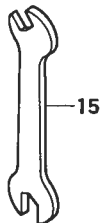
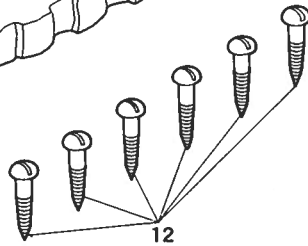
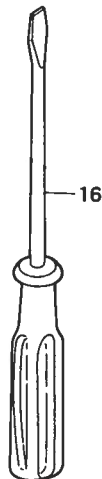
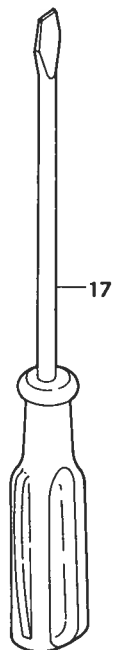
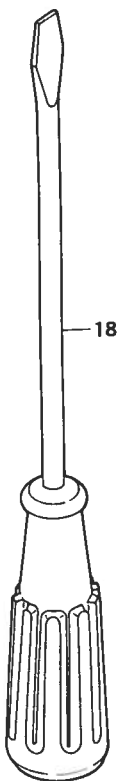
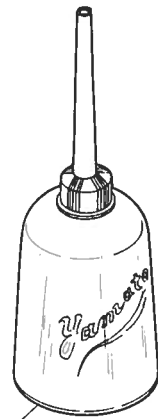
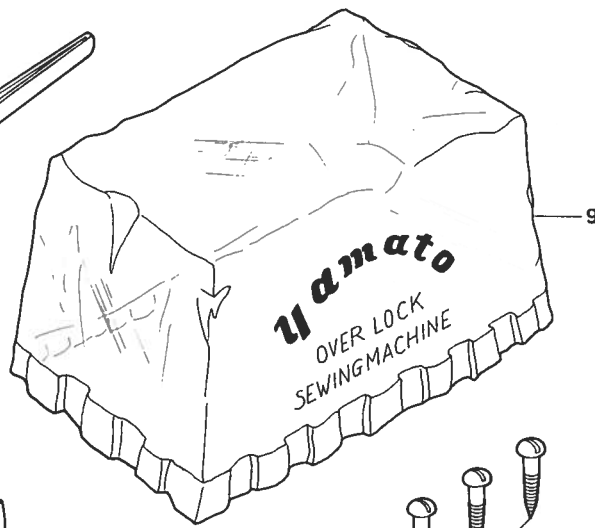
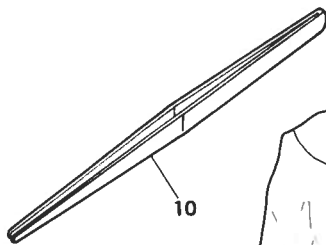
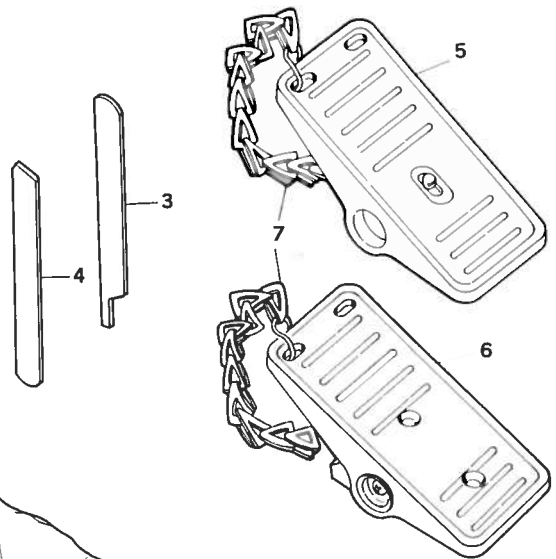
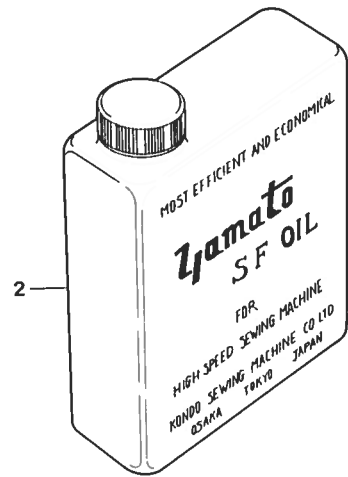
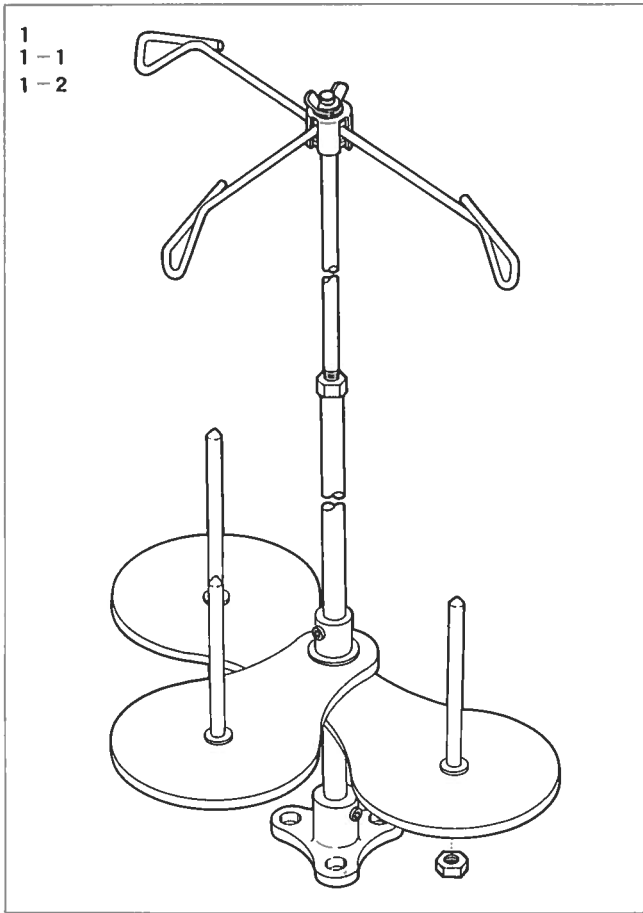

ACCESSORY

アクセサリ

22

Ref. No.	Parts No.	Description	品名	Amt. Req.	
				Exp't.	国内
1	37981	Thread Stand 2 Spool Type Complete Set	2本糸用糸立(組)	1	1
1-1	37982	Thread Stand 3 Spool Type Complete Set	3本糸用糸立(組)	1	1
1-2	37983	Thread Stand 4 Spool Type Complete Set	4本糸用糸立(組)	1	1
2	37933	Oil	オイル	1	1
3	38332	Upper Knife	上メス	1	
4	30421	Lower Knife	下メス	1	
5	37907	Pedal Complete Set	ペダル(組)	1	
6	37911	Pedal Complete Set	ペダル(組)		1
7	37912	Chain	鎖	1	1
8	37932	Oiler	油差シ	1	1
9	37936	Machine Cover	ビニールカバー	1	1
10	37909	Thread Tweezers	ピンセット	1	1
11	37913	Attachment Box	付属品箱	1	1
12	6902	Wood Screw	木ネジ	6	4
13	—	Needle (DC×1)	針	10	10
14	37916	Arren Wrench	キーレンチ	1	1
15	37915	Wrench	両口スパナ	1	1
16	37903	Screw Driver (Small)	ドライバー(小)	1	1
17	37902	Screw Driver (Medium)	ドライバー(中)	1	1
18	37901	Screw Driver (Large)	ドライバー(大)	1	1

INDEX

Parts No.	Page No.	Ref. No.	Parts No.	Page No.	Ref. No.	Parts No.	Page No.	Ref. No.	Parts No.	Page No.	Ref. No.
18	5	22	925	19	17	1419	14	24	3639	9	12
18	8	17	989	9	2	1457	3	30	4236	12	34
56	3	23	1060	7	24	1457	5	12	4237	5	18
56	13	34	1092	3	19	1457	7	2	4237	11	24
62	4	20	1132	8	4	1457	9	9	4237	15	26
144	1	24	1132	12	14	1457	10	18	4310	19	29
281	7	16	1132	15	31	1457	16	10	4353	8	24
282	4	15	1156	7	5	1457	18	13	4353	11	7
290	5	21	1156	15	2	1457	19	16	4353	20	21
290	15	21	1156	18	16	1613	2	20	4358	3	12
290	18	8	1170	4	2	1613	8	13	4358	10	23
291	4	11	1170	5	8	1613	11	29	4358	11	13
294	9	11	1174	8	15	1613	13	23	4358	12	9
296	12	18	1174	8	21	1732	4	23	4358	13	8
304	4	5	1174	12	16	1817	3	21	4358	14	9
330	3	10	1174	15	14	1817	13	36	4358	16	22
330	13	4	1174	18	5	1904	3	6	4358	19	25
334	6	15	1175	1	10	1904	11	19	5028	7	18
340	6	4	1175	2	10	2022	5	2	5046	18	11
340	10	14	1175	7	32	2022	9	21	5083	2	27
340	17	8	1175	11	22	2043	7	15	5345	11	35
340	19	14	1175	15	24	2043	18	34	5345	13	32
340	20	8	1175	18	32	2086	8	19	5540	7	12
346	18	22	1176	12	19	2086	15	12	5541	6	22
444	3	9	1176	15	22	2127	7	25	6049	18	20
444	13	3	1176	18	7	2133	6	16	6053	18	23
511	7	23	1186	4	18	2214	6	12	6255	18	17
530	6	21	1196	1	12	2237	2	3	6762	16	9
531	2	17	1196	3	14	2237	7	29	6902	22	12
532	15	6	1196	5	16	2285	6	14	7143	6	6
541	1	9	1196	10	8	2308	6	8	7302	5	26
551	7	11	1196	11	11	2308	17	9	7311	4	4
551	18	21	1196	13	6	2308	20	9	7311	5	5
554	2	12	1196	16	20	2347	14	23	7311	6	19
554	6	5	1196	19	23	2368	5	3	7311	8	2
554	17	10	1202	7	27	2371	6	24	7311	11	39
554	20	10	1202	15	5	2419	1	23	7311	14	19
555	7	17	1208	1	14	2419	13	33	7405	7	22
562	2	6	1208	2	32	3311	4	16	7405	12	31
566	10	38	1208	10	36	3410	10	28	7405	15	36
566	16	3	1208	14	6	3410	16	25	7509	8	16
566	19	3	1208	19	37	3410	19	29	7425	7	10
567	10	2	1218	2	13	3433	11	36	7609	1	5
567	16	2	1222	12	12	3433	13	31	7616	1	27
567	19	2	1222	15	29	3433	14	32	7616	7	8
568	2	25	1227	3	16	3433	18	37	7618	1	29
578	2	24	1227	8	8	3434	6	2	7618	2	16
710	2	8	1228	6	10	3434	9	15	7619	2	21
726	1	17	1228	11	3	3591	9	3	7619	11	28
901	1	15	1228	14	12	3593	9	4	7619	13	25
925	5	13	1228	15	8	3635	4	8	7650	9	7
925	7	3	1228	17	16	3635	5	10	7650	14	31
925	10	19	1228	20	15	3635	9	17	7650	15	18
925	16	11	1228	21	3	3637	17	18	7658	10	30
925	18	14	1335	5	20	3637	21	5	7658	19	31

INDEX

Parts No.	Page No.	Ref. No.	Parts No.	Page No.	Ref. No.	Parts No.	Page No.	Ref. No.	Parts No.	Page No.	Ref. No.
7666	10	17	37120	4	3	37368	17	11	37455	7	31
7666	16	16	37122	4	19	37368	20	11	37456	7	26
7666	19	18	37121	5	9	37369	17	7	37458	12	28
7667	10	10	37127	4	7	37369	20	7	37460	11	30
7667	19	9	37128	4	9	37370	17	12	37460	15	41
7668	10	3	37130	4	1	37370	21	13	37461	15	23
7668	16	4	37130	5	9	37372	17	13	37462	11	40
7668	19	4	37132	4	6	37372	20	12	37463	15	42
7678	2	23	37133	9	13	37373	17	17	37464	15	25
7763	2	5	37134	9	14	37373	21	4	37465	15	43
7817	3	26	37140	6	3	37374	17	14	37466	11	25
7817	13	19	37141	6	23	37376	17	15	37466	15	27
7904	13	15	37144	6	11	37376	21	2	37467	12	10
7904	17	6	37145	6	18	37378	17	20	37467	15	16
7904	20	6	37146	6	13	37378	21	8	37468	15	17
9091	2	7	37147	6	17	37379	17	21	37469	12	23
9209	19	13	37148	6	20	37379	21	7	37469	15	34
9209	10	15	37150	4	12	37382	17	28	37470	12	21
9526	18	30	37151	4	17	37382	21	17	37470	15	32
9932	4	10	37163	6	9	37383	17	29	37471	12	22
30413	12	13	37163	11	2	37383	21	16	37471	15	33
30421	22	4	37163	20	14	37396	17	23	37472	12	29
31111	3	5	37170	3	2	37397	17	24	37472	15	37
31111	11	18	37170	11	15	37397	21	11	37473	12	27
31111	13	14	37170	13	11	37402	7	9	37473	15	38
31111	17	5	37170	17	2	37405	7	19	37474	12	30
31111	20	5	37170	20	2	37406	7	20	37474	15	35
37016	3	20	37184	11	6	37409	9	19	37475	12	20
37048	12	5	37184	20	20	37409	9	23	37475	15	30
37048	14	3	37249	7	31-1	37410	7	30	37477	15	39
37049	9	18	37249	17	19	37415	7	28	37478	12	11
37057	11	38	37256	12	26	37416	7	21	37478	15	28
37057	14	18	37256	14	14	37430	10	9	37479	12	24
37058	11	43	37257	15	3	37430	19	8	37481	16	15-1
37058	14	30	37262	11	12	37431	10	25	37483	12	35
37059	12	1	37262	13	7	37431	16	8	37487	11	21
37060	11	10	37268	12	33	37431	16	18-1	37489	11	44
37060	13	5	37271	12	6	37431	19	21	37495	11	31
37062	12	2	37272	12	37	37432	10	21	37496	12	32
37062	14	20	37273	12	36	37432	16	6	37500	6	7
37064	12	7	37279	12	25	37433	10	5	37507	9	8
37064	14	4	37279	15	40	37433	16	6-1	37508	8	14
37065	12	4	37286	11	23	37433	16	15	37509	8	3
37076	14	16	37288	12	42	37433	19	6	37510	8	9
37101	3	11	37290	12	41	37435	16	8-1	37512	8	10
37102	3	13	37301	5	15	37435	16	18	37514	8	11
37103	3	29	37302	5	25	37437	14	27	37529	6	9-1
37104	3	28	37304	5	14	37438	14	26	37533	6	7-1
37105	3	7	37307	5	17	37439	14	15	37536	8	18
37106	3	27	37308	5	27	37442	7	6	37537	8	23
37107	3	15	37311	5	4	37443	7	7	37538	8	22
37108	3	17	37315	5	19	37452	11	32	37540	2	26
37109	3	18	37319	12	39	37452	13	28	37544	1	13
37113	13	35	37320	12	40	37453	11	33	37545	9	5
37115	3	22	37322	12	38	37453	13	29	37547	9	10

INDEX

Parts. No.	Page No.	Ref. No.	Parts. No.	Page No.	Ref. No.	Parts. No.	Page No.	Ref. No.	Parts. No.	Page No.	Ref. No.
37552	6	1	37650	9	6	37706	20	18	37865	18	25
37552	8	1	37651	7	14	37709	2	4	37866	18	24
37553	8	12	37652	7	4	37715	16	13	37868	20	13
37554	8	7	37653	7	1	37732	17	22	37869	18	27
37558	8	6	37654	9	16	37734	17	14	37870	18	29
37560	8	5	37654	9	22	37734	17	27	37871	20	17
37564	8	20	37659	10	26	37755	14	1	37871	21	6
37569	1	6	37659	16	23	37757	14	2	37872	18	31
37601	2	34	37659	19	27	37799	11	37	37873	18	9
37604	1	18	37660	10	27	37799	14	25	37874	18	10
37605	1	19	37660	16	24	37800	15	15	37876	12	17
37607	1	20	37660	19	28	37804	13	9	37876	15	20
37606	1	21	37666	10	13	37805	11	27	37876	18	6
37609	1	3	37666	19	12	37805	13	24	37877	18	3
37610	1	4	37667	10	16	37809	11	34	37878	19	10
37612	1	2	37667	16	12	37809	13	30	37879	19	20
37613	1	11	37667	19	15	37811	15	10	37880	16	21
37615	1	25	37668	10	6	37812	11	20	37883	12	15
37616	1	26	37668	16	7	37812	13	16	37883	15	19
37617	1	30	37668	19	7	37813	13	20	37883	18	4
37618	1	28	37669	10	1	37814	13	21	37886	12	8
37619	2	19	37669	16	1	37816	14	22	37886	14	8
37620	2	15	37669	19	1	37818	12	3	37887	18	33
37621	2	14	37670	10	11	37818	14	21	37890	19	19
37622	1	8	37671	10	20	37821	15	4	37892	20	19
37623	1	1	37675	10	4	37822	15	9	37893	20	22
37624	2	1	37675	16	5	37823	15	7	37894	17	25
37626	2	33	37675	19	5	37824	15	11	37894	21	12
37627	2	31	37676	10	22	37825	15	1	37896	18	18
37628	1	16	37676	19	24	37826	14	7	37897	18	35
37632	3	25	37677	10	7	37827	14	5	37899	21	14
37632	11	16	37677	16	19	37831	11	41	37901	22	18
37632	13	18	37677	19	22	37831	14	28	37902	22	17
37633	3	3	37678	2	22	37832	14	17	37903	22	16
37633	13	12	37679	2	28	37833	13	26	37907	22	5
37633	17	3	37680	2	29	37834	13	27	37909	22	10
37633	20	3	37681	2	30	37835	14	13	37911	22	6
37634	3	1	37684	10	29	37841	11	8	37912	22	7
37634	11	14	37684	16	26	37841	13	1	37913	22	11
37634	13	10	37684	19	30	37842	11	26	37915	22	15
37634	17	1	37685	10	37	37842	13	22	37916	22	14
37634	20	1	37685	19	26	37843	11	42	37932	22	8
37635	3	4	37690	5	1	37843	14	29	37933	22	2
37635	13	13	37691	10	24	37845	15	13	37936	22	9
37635	17	4	37691	16	17	37848	14	10	37981	22	1
37635	20	4	37692	2	18	37850	14	11	37982	22	1-1
37635	11	17	37696	1	22	37851	18	1	37983	22	1-2
37636	3	24	37697	10	12	37856	18	36	38064	7	13
37636	13	17	37697	16	14	37857	18	12	38074	13	37
37637	2	11	37697	19	11	37858	18	2	38139	17	26
37638	2	9	37699	2	2	37860	18	15	38142	21	9
37645	9	20	37702	11	4	37861	18	28	38142	21	18
37647	5	11	37703	9	1	37862	17	19	38146	21	1
37648	5	23	37705	11	5	37862	18	19	38146	21	15
37649	5	24	37706	11	1	37864	18	38	38147	21	10

MEMO

