

Jamato

INDUSTRIAL SEWING MACHINE

ILLUSTRATED SPARE PARTS LIST FOR HIGH SPEED OVERLOOK MACHINE

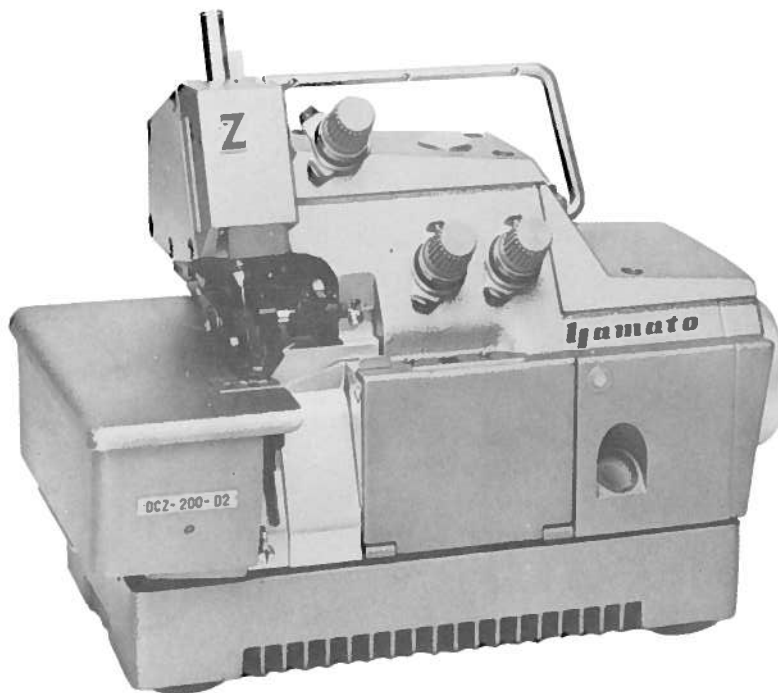

MODEL

DCZ-200	DCZ-201	DCZ-202	DCZ-203	DCZ-203S	DCZ-203M
DCZ-205	DCZ-206	DCZ-208	DCZ-209	DCZ-220	DCZ-220W
DCZ-221	DCZ-222	DCZ-223	DCZ-245	DCZ-246	DCZ-270
<hr/> K		<hr/> C		<hr/> V	

KONDO SEWING MACHINE CO.,LTD.



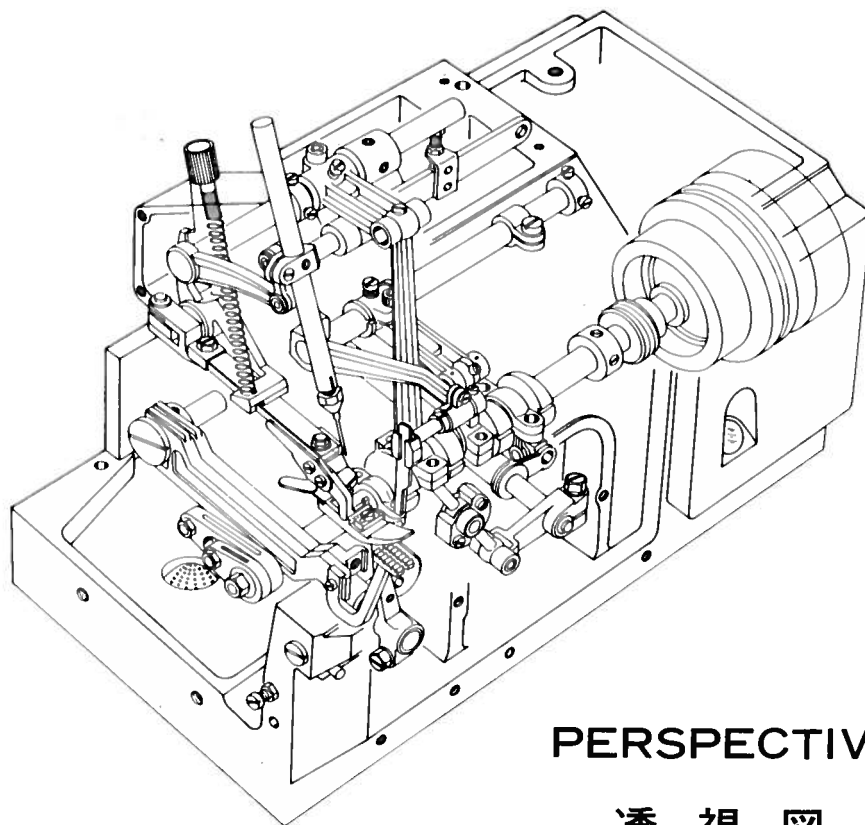

PERSPECTIVE

透視図

CONTENTS

目次

MISCELLANEOUS COVER (1)	カバー関係(1)..... 1
MISCELLANEOUS COVER (2)	カバー関係(2)..... 2
THREAD EYELET AND BASE	糸道、ベース関係..... 3
MISCELLANEOUS BUSHING AND CRANK SHAFT	ブッシュ主軸関係..... 4
NEEDLE BAR AND KNIFE DRIVING MECHANISM	針棒、メス機構..... 5
LOOPER DRIVING MECHANISM	ルーバー機構..... 6
PRESSER FOOT MECHANISM	押工機構..... 7
FEED DRIVING MECHANISM	送り機構..... 8
OIL LUBRICATING SYSTEM	給油関係..... 9
DCZ-200,-201,-203,-203S,-205,-206,-209 EXCLUSIVE PARTS	サブクラス専用部品..... 10
DCZ-220,-220W,-221,-270 EXCLUSIVE PARTS	サブクラス専用部品..... 11
DCZ-202,-222,-223 EXCLUSIVE PARTS (1)	サブクラス専用部品..... 12
DCZ-202,-222,-223 EXCLUSIVE PARTS (2)	サブクラス専用部品..... 13
DCZ-203M,-245,-246 EXCLUSIVE PARTS	サブクラス専用部品..... 14
DCZ-208 EXCLUSIVE PARTS	サブクラス専用部品..... 15
“K” DEVICE	“K”装置..... 16
“C” & “V” DEVICE	“C”及び“V”装置..... 17
ACCESSORY	アクセサリー..... 18
INDEX	索引..... 19



Please always mention our parts number when placing your orders.
部品の御注文は部品番号で!!

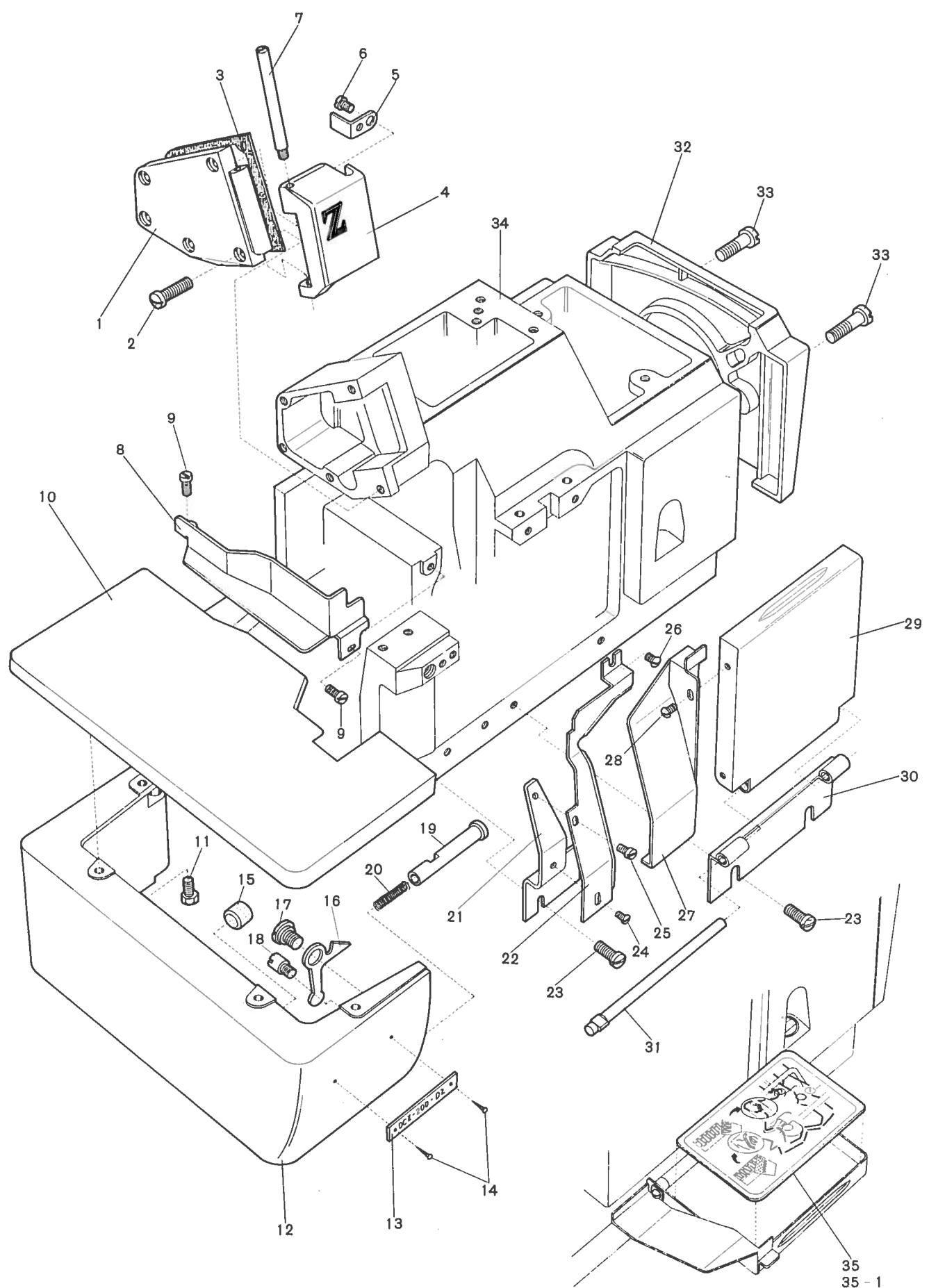

- 35
- 35 - 1
- 35 - 2
- 35 - 3
- 35 - 4
- 35 - 5

MISCELLANEOUS COVER(1)

カバー関係(1)

<u>Ref. No.</u>	<u>Parts No.</u>	<u>Description</u>	<u>品 名</u>	<u>Amt. Req.</u>
1	32617	Side Cover	ベッド横蓋	1
2	9150	Screws for 32617	ベッド横蓋止 ネジ	5
3	32618	Side Cover Gasket	ベッド横蓋バックシム	1
4	32619	Needle Thread Cover	針糸カバー	1
5	32620	Needle Thread Cover Latch Spring	針糸カバーバネ	1
6	7302	Screws for 32620	針糸カバーバネ止 ネジ	2
7	32622	Needle Thread Cover Pin	針糸カバーピン	1
8	32623	Fabric Guard	布滑り案内板	1
9	4353	Screws for 32623	布滑り案内板止 ネジ	2
10	32602	Cloth Plate (Upper)	大カバー	1
11	7605	Screws for 32602	大カバー止 ネジ	4
12	32603	Cloth Plate (Lower)	横カバー	1
13		Model Indicate Plate	型式板	1
14	726	Rivets for Model Indicate Plate	リベット	2
15	32604	Cloth Plate Rubber Cushion	埋メ座(大)	1
16	30126	Cloth Plate Latch	横カバーフック	1
17	6040	Screw for 30126	横カバーフック止 ネジ	1
18	5095	Stopper for 30126	横カバーフックストッパー	1
19	32628	Cloth Plate Latch Plunger	横カバーピン	1
20	32629	Cloth Plate Latch Spring	横カバーバネ	1
21	32640	Chip Guard Supporter	切屑落シ取付板	1
22	32610	Chip Guard (Fix)	切屑落シ板(大)	1
23	4440	Screws for 32607, 32640	止 ネジ	4
24	1330	Screw for 32610	切屑落シ板(大)止 ネジ	1
25	1222	Screw for 32610	切屑落シ板(大)止 ネジ	1
26	1326	Screw for 32610	切屑落シ板(大)止 ネジ	1
27	32611	Chip Guard (Open)	切屑落シ板(小)	1
28	5131	Screws for 32611	切屑落シ板(小)止 ネジ	2
29	32606	Front Cover	前開キカバー	1
30	32607	Front Cover Hinge	前開キカバーヒンジ	1
31	32608	Front Cover Hinge Pin	前開キカバーピン	1
32	32477	Belt Cover	ブリーカーカバー	1
33	5089	Screws for 32477	ブリーカーカバー止 ネジ	2
34	32600	Frame	ベッド	1
35	865	Threading Chart for DCZ-200, -203	糸通シ図	1
35-1	866	Threading Chart for DCZ-202	糸通シ図	1
35-2	867	Threading Chart for DCZ-203S	糸通シ図	1
35-3	868	Threading Chart for DCZ-222, -223	糸通シ図	1
35-4	869	Threading Chart for DCZ-220W, -220, -221	糸通シ図	1
35-5	858	Threading Chart for DCZ-270	糸通シ図	1

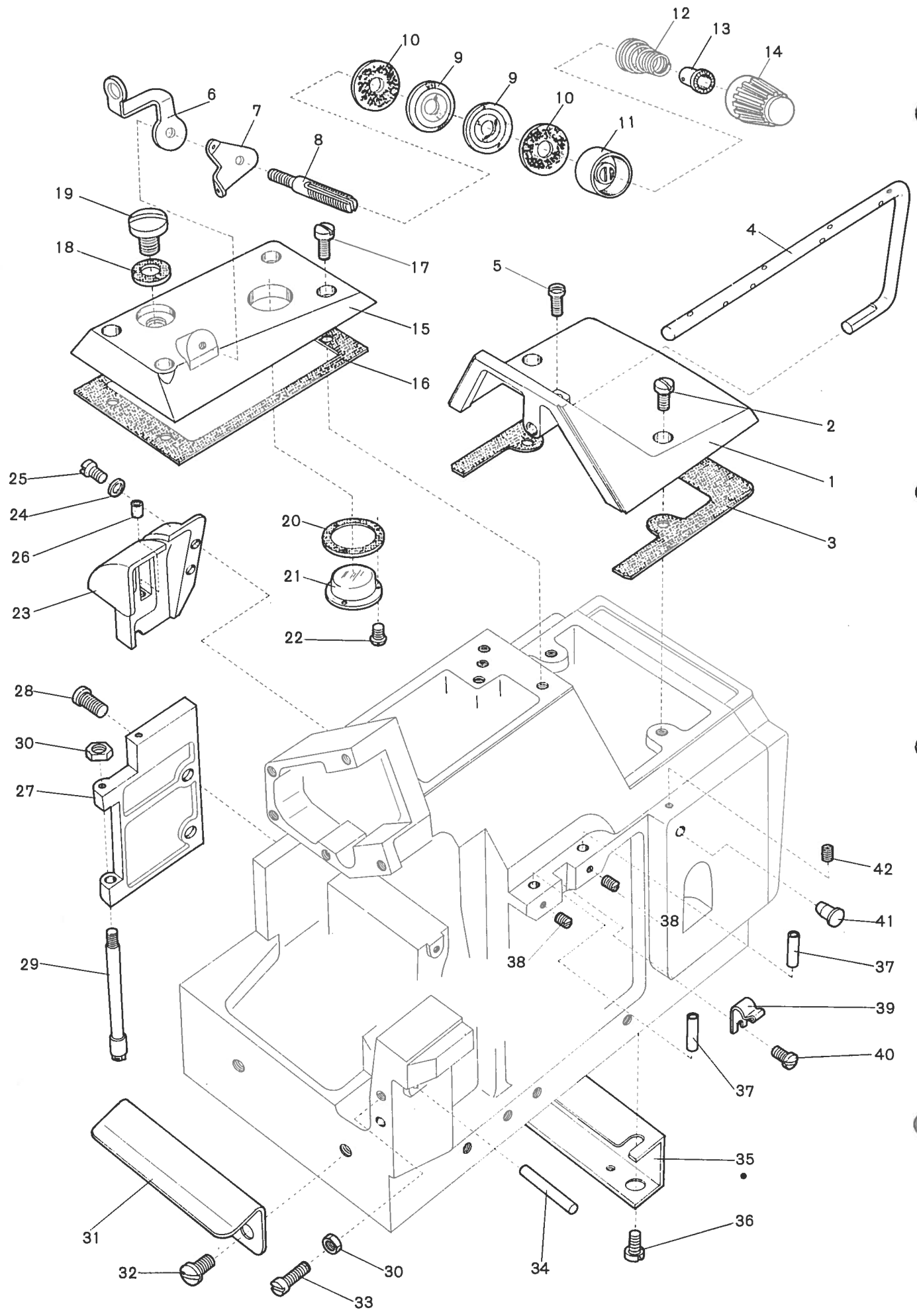

Ref. No.	Parts No.	Description	品名	Amt. Req.
1	32613	Top Cover (Right)	上蓋(右)	1
2	9150	Screws for 32613	上蓋(右)止ネジ	2
3	32597	Top Cover (Right) Gasket	上蓋パッキン(右)	1
4	32970	Thread Lead Bar	糸道棒	1
5	4435	Screw for 32970	糸道棒止ネジ	1
6	32974	Thread Lead Bar Stay	糸道棒振レ止メ	1
7	32962	Tension Disc Eyelet	調子台糸道	1
8	6544	Needle Thread Tension Post	糸調子棒(長)	1
9	01111	Tension Discs	糸調子皿	2
10	286	Felts for 01111	フェルト	2
11	37635	Thread Tension Spring Retainer	渦巻バネキャップ(下)	1
12	32971	Needle Thread Tension Spring	渦巻バネ(大)	1
13	30254	Tension Spring Bushing	糸調子ナット廻り止メ	1
14	32965	Thread Tension Spring Cap	渦巻キバネキャップ(上)	1
15	32614	Top Cover (Left)	上蓋(左)	1
16	32615	Top Cover (Left) Gasket	上蓋パッキン(左)	1
17	9150	Screws for 32614	上蓋(左)止ネジ	4
18	525	Seal for 5075	給油ネジパッキン	1
19	5075	Oil Hole Screw	給油口蓋ネジ	1
20	32924	Oil Sight Top Window Seal	油量覗キャップパッキン	1
21	32930	Oil Sight Top Window	油量覗キャップ	1
22	1333	Screws for 32930	油量覗キャップ止ネジ	3
23	32624	Foot Lifter Hinge Cover	ベッド後蓋	1
24	550	Washers for 32624	ベッド後蓋ワッシャ	2
25	4440	Screws for 32624	ベッド後蓋止ネジ	2
26	32365	Presser Foot Release Lever Cushion	埋メ座(小)	1
27	32605	Cloth Plate Hinge	横カバーヒンジ	1
28	5089	Screws for 32605	横カバーヒンジ止ネジ	2
29	32586	Cloth Plate Hinge Pin	横カバーヒンジピン	1
30	334	Nuts for 32586, 1156	ナット	2
31	32599	Frame Hanger	ベッドハンガー	1
32	7678	Screws for 32599	ベッドハンガー止ネジ	2
33	1156	Stopper Screw for Cloth Plate	横カバーストッパーネジ	1
34	698	Cloth Plate Latch Pin	横カバーフック掛ケピン	1
35	32484	Under Pump Oil Filter Screen Supporter	汙過網取付台	1
36	4440	Screws for 32484	汙過網取付台止ネジ	2
37	32963	Looper Thread Tubes	糸道パイプ(16m/m)	2
38	1459	Screws for 32963	糸道パイプ止ネジ	2
39	32609	Front Cover Latch Spring	前開キカバーバネ	1
40	4358	Screw for 32609	前開キカバーバネ止ネジ	1
41	32612	Front Seal Plug	詰栓	1
42	3434	Screw for 32612	詰栓止ネジ	1

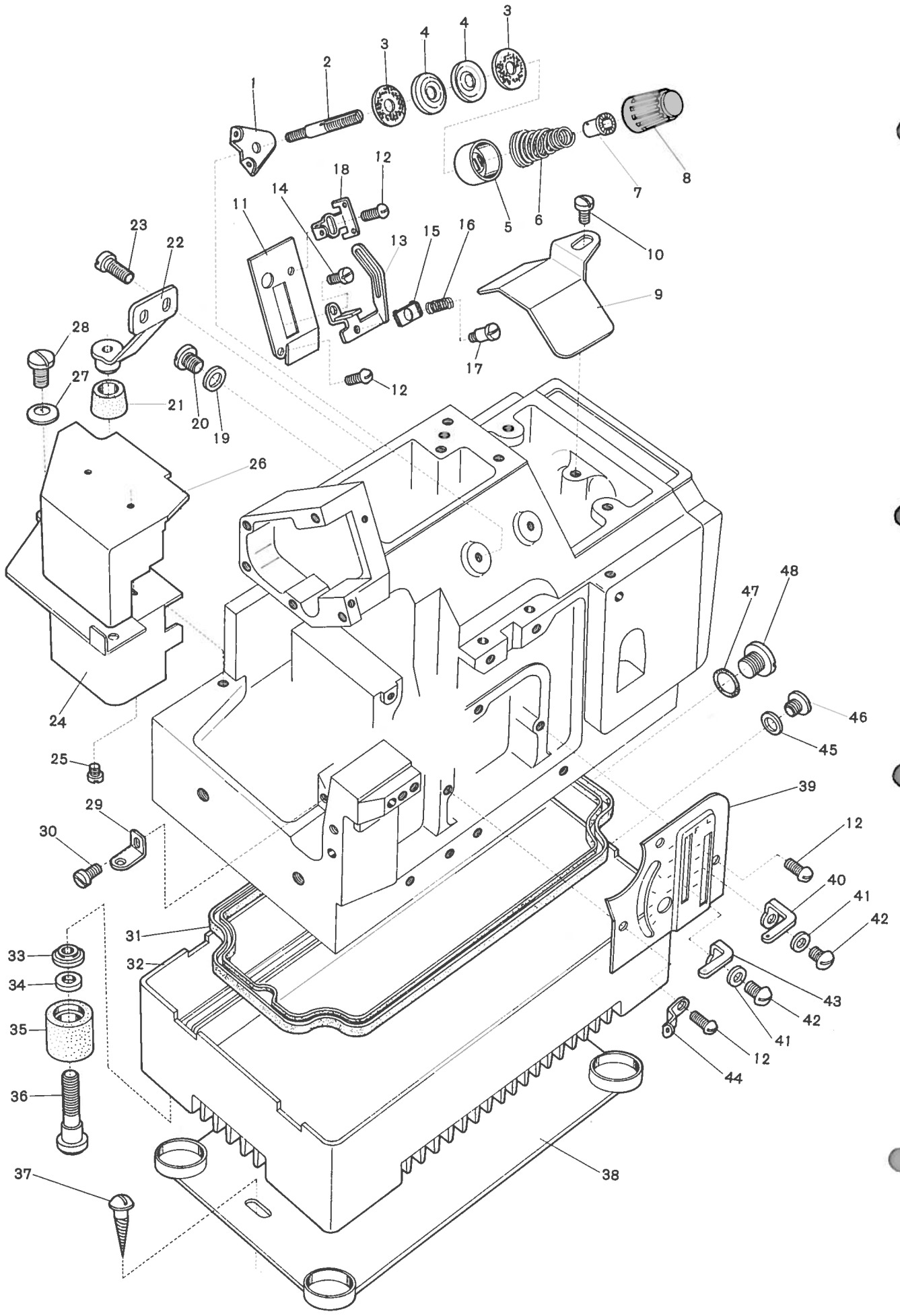

<u>Ref. No.</u>	<u>Parts No.</u>	<u>Description</u>	<u>品 名</u>	<u>Amt. Req.</u>
1	32962	Tension Disc Eyelets for Looper	調子台糸道	2
2	6542	Looper Thread Tension Posts	糸調子棒(短)	2
3	286	Felts for 01111	フェルト	4
4	01111	Tension Discs	糸調子皿	4
5	37635	Thread Tension Spring Retainers	渦巻バネキャップ(下)	2
6	32952	Looper Thread Tension Springs	渦巻バネ(細)	2
7	30254	Tension Spring Bushings	糸調子ナット廻り止メ	2
8	32965	Thread Tension Spring Caps	渦巻バネキャップ(上)	2
9	32663	Worm Cover	ウォームカバー	1
10	4438	Screw for 32663	ウォームカバー止ネジ	1
11	32627	Needle Bar Connecting Link Cover	針棒カバー	1
12	1326	Screws for 32424, 32627, 34010	止ネジ	5
13	32423	Needle Bar Thread Retainer Bracket	小調子台	1
14	7006	Screw for 32423	小調子台止ネジ	1
15	32425	Needle Bar Thread Retainer Plate	小調子皿	1
16	32426	Needle Bar Thread Retainer Spring	小調子皿バネ	1
17	1092	Screw for 32425	小調子皿止ネジ	1
18	32424	Needle Thread Eyelet	針糸道	1
19	567	Seal for 5062	ベッドネジ蓋パッキン	1
20	5062	Oil Hole Screw	ベッドネジ蓋	1
21	32976	Stay Rubber Cushion	支工具ゴム座	1
22	32977	Frame Stay	ベット支工具	1
23	9150	Screws for 32977	ベッド支工具止ネジ	2
24	32475	Feed Mechanism Oil Shield	送りリンクカバー(小)	1
25	1228	Screws for 32475	送りリンクカバー(小)止ネジ	2
26	32625	Feed Mechanism Cover	送りリンクカバー	1
27	10	Washer for Hinge Screw	送りリンクカバーヒンジ座金	1
28	6004	Hinge Screw for 32625	送りリンクカバーヒンジネジ	1
29	32626	Feed Mechanism Cover Latch Spring	送りリンクカバーバネ	1
30	4351	Screw for 32626	送りリンクカバーバネ止ネジ	1
31	32975	Base Gasket	ベースパッキン	1
32	32973	Base	ベース	1
33	32375	Base Oil Seals	ベース止ネジパッキン	4
34	563	Washers for 32973	ベース止ネジ座金	4
35	32377	Base Rubber Cushions	ベースゴム座	4
36	6262	Screws for 32973	ベース止ネジ	4
37	6910	Wood Screws	木ネジ	2
38	32660	Rubber Cushion Holder Plate	ベースプレート	1
39	34010	Looper Thread Eyelet Supporter	前カバー	1
40	32955	Looper Thread Eyelet (Right)	ルーバー糸道(右)	1
41	532	Washers for 32955, 32358	ルーバー糸道座金	2
42	1330	Screws for 32955, 32358	ルーバー糸道止ネジ	2
43	32358	Looper Thread Eyelet (Left)	ルーバー糸道(左)	1
44	32960	Lower Looper Thread Eyelet	下ルーバー糸道	1
45	316	Drain Hole Seal for Outer	ベース油抜キパッキン(小)	1
46	9851	Drain Hole Screw for Outer	ベース油抜キネジ(小)	1
47	32421	Drain Hole Seal for Inner	オリング	1
48	5075	Drain Hole Screw for Inner	ベース油抜キネジ(大)	1

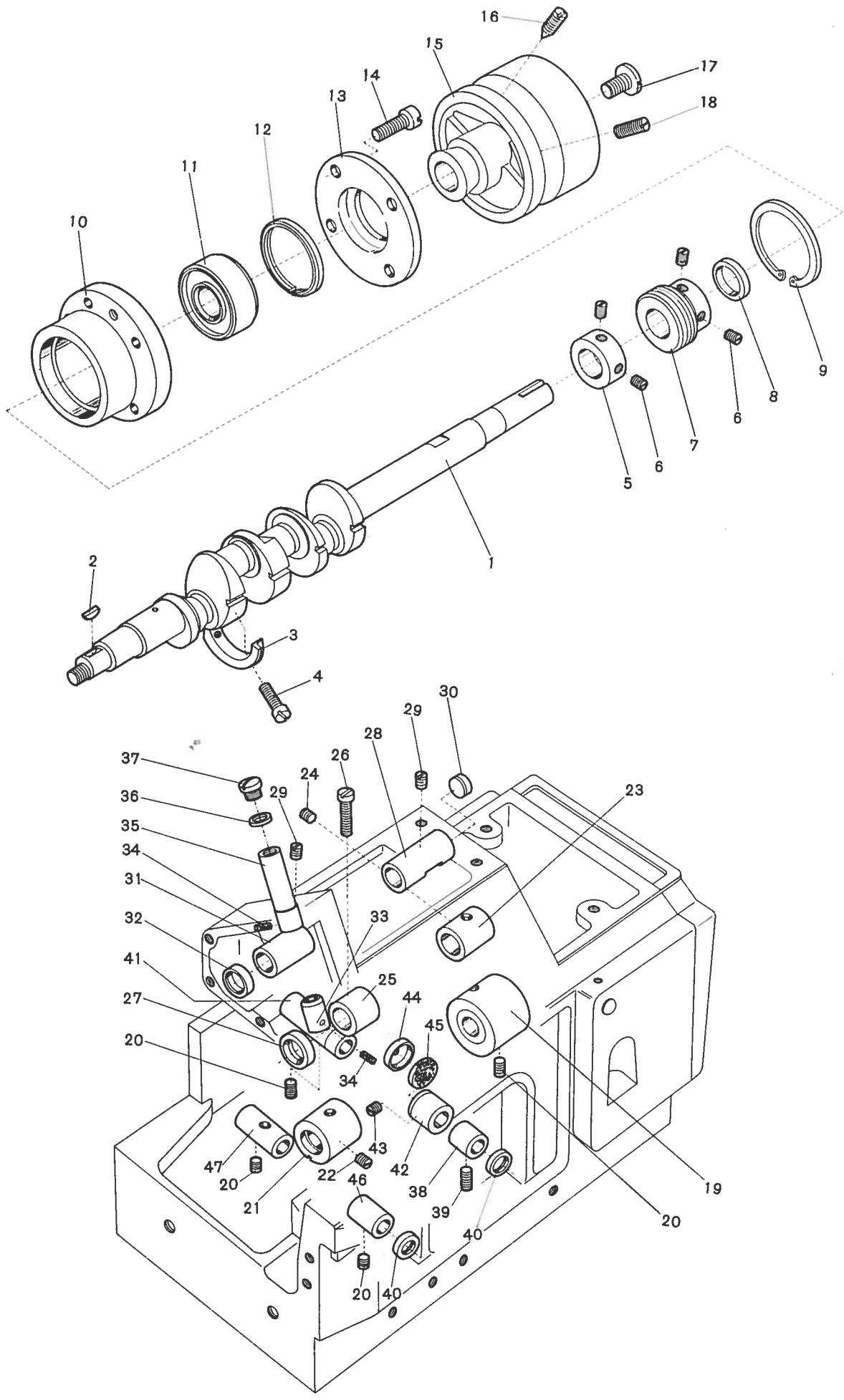

Ref. No.	Parts No.	Description	品名	Amt. Req.
1	32774	Crank Shaft	クランクシャフト	1
2	32780	Feed Driving Eccentric Key	キー	1
3	32773	Crank Shaft Counterweight (Middle)	バランスウエイト(大)	1
4	7609	Screws for 32773	バランスウエイト(大)止ネジ	2
5	32820	Crank Shaft Thrust Collar	スラストカラー	1
6	7650	Screws for 32820, 32925	止ネジ	4
7	32925	Oil Pump Driving Worm	ウォーム	1
8	32779	Crank Shaft Ball Bearing Retaining Washer	ベアリング位置決めリング	1
9	32778	Crank Shaft Ball Bearing Retaining Ring (Inner)	ストップリング	1
10	32775	Crank Shaft Ball Bearing Housing	大ブッシュ	1
11	32777	Crank Shaft Ball Bearing	ボールベアリング	1
12	32818	Crank Shaft Ball Bearing Retaining Ring (Outer)	ボールベアリング押エ	1
13	32817	Crank Shaft Ball Bearing Housing Cap	大ブッシュ蓋	1
14	4441	Screws for 32817	大ブッシュ蓋止ネジ	4
15	32772	Pulley	プーリー	1
16	3591	Main Screw for 32772	プーリー決めネジ	1
17	4402	Cap Screw for 32772	プーリー位置決めネジ	1
18	9203	Sub Screw for 32772	プーリー止ネジ	1
19	32781	Crank Shaft Bushing (Inner)	中ブッシュ	1
20	9209	Screws for 32781, 32793, 32794, 32795	ブッシュ止ネジ	4
21	32782	Crank Shaft Bushing (Left)	小ブッシュ	1
22	3595	Screw for 32782	小ブッシュ止ネジ	1
23	32904	Upper Knife Driving Shaft Bushing (Right)	上メス軸ブッシュ(右)	1
24	3654	Screw for 32904	上メス軸ブッシュ(右)止ネジ	1
25	32905	Upper Knife Driving Shaft Bushing (Left)	上メス軸ブッシュ(左)	1
26	2133	Screw for 32905	上メス軸ブッシュ(左)止ネジ	1
27	32906	Upper Knife Driving Shaft Oil Seal	上メス軸オイルシール	1
28	32648	Needle Bar Driving Crank Bushing (Right)	針棒クランク軸ブッシュ(右)	1
29	1457	Screws for 32647, 32648	針棒クランク軸ブッシュ止ネジ	2
30	32650	Needle Bar Driving Crank Bushing Plug	詰栓(12φ)	1
31	32647	Needle Bar Driving Crank Bushing (Left)	針棒クランク軸ブッシュ(左)	1
32	32684	Needle Bar Driving Crank Oil Seal	針棒クランク軸オイルシール	1
33	32653	Needle Bar Bushing (Lower)	針棒ブッシュ(下)	1
34	304	Oil Wicks for 32652, 32653	油芯	2
35	32652	Needle Bar Bushing (Upper)	針棒ブッシュ(上)	1
36	526	Seal for 32652	針棒ブッシュ(上)蓋ネジパッキン	1
37	3636	Cap Screw for 32652	針棒ブッシュ(上)蓋ネジ	1
38	34518	Upper Looper Driving Shaft Bushing (Front)	上ルーバー軸ブッシュ(前)	1
39	1435	Screw for 34518	上ルーバー軸ブッシュ(前)止ネジ	1
40	30291	Looper Shaft Oil Seals	ルーバー軸オイルシール	2
41	32793	Upper Looper Driving Shaft Bushing (Rear)	上ルーバー軸ブッシュ(後)	1
42	32349	Upper Looper Bar Guide Bushing	ルーバー案内ブッシュ	1
43	1448	Screw for 32802	ルーバー案内ブッシュ止ネジ	1
44	32350	Upper Looper Bar Guide Bushing Cap	ルーバー案内ブッシュ蓋	1
45	527	Oil Felt for 32868	ルーバー案内ブッシュフェルト	1
46	32794	Lower Looper Driving Shaft Bushing (Front)	下ルーバー軸ブッシュ(前)	1
47	32795	Lower Looper Driving Shaft Bushing (Rear)	下ルーバー軸ブッシュ(後)	1

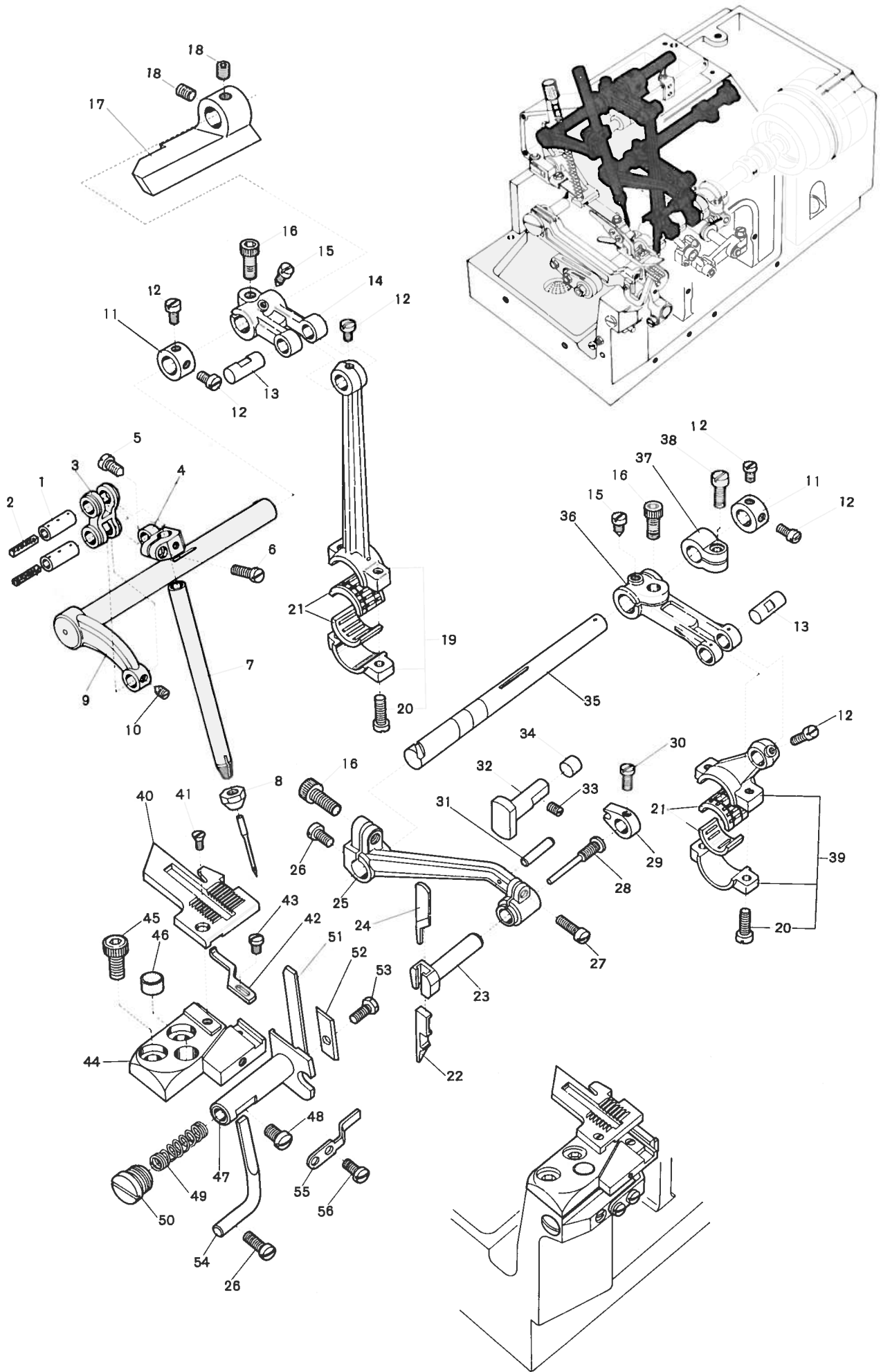

<u>Ref. No.</u>	<u>Parts No.</u>	<u>Description</u>	<u>品 名</u>	<u>Amt. Req.</u>
1	90320	Needle Bar Connection Link Pins	針棒リンクピン	2
2	282	Oil Wicks for 90320	針棒リンク油芯	2
3	90321	Needle Bar Connection Link	針棒リンク	1
4	32651	Needle Bar Connecting Bracket	針棒抱キ	1
5	4313	Screw for 90320 (32651)	針棒リンクピン止ネジ	1
6	1186	Screw for 32651	針棒抱キ止ネジ	1
7	37122	Needle Bar for Single Needle	針棒	1
8	62	Needle Clamping Nut	針止ナット	1
9	32645	Needle Bar Driving Crank	針棒クランク軸	1
10	3311	Screw for 90320 (32645)	針棒リンクピン止ネジ	1
11	32646	Needle Bar Driving Crank Collars	針棒クランク軸カラー	2
12	9604	Screws for 32646, 32921, 32900	止ネジ	6
13	32921	Connecting Rod Pin	ピン	2
14	32644	Needle Bar Driving Lever	針棒クランク軸腕	1
15	9517	Sub Screws for 32644, 32902	補助ネジ	2
16	5520	Main Screws for 32644, 32902, 32910	止ネジ	3
17	32662	Needle Bar Driving Crank Counterweight	針棒ウエイト	1
18	3635	Screws for 32662	針棒ウエイト止ネジ	2
19	32670	Needle Bar Connecting Rod	針棒ロット	1
20	5071	Screws for 32670, 32900	止ネジ	4
21	32819	Connecting Rod Roller Bearings	ニードルベアリング	2
22	32913	Upper Knife Clamp	上メス押シ	1
23	32911	Upper Knife Holder	上メス抱キ	1
24	32914	Upper Knife	上メス	1
25	32910	Upper Knife Driving Arm	上メス台	1
26	4437	Screws for 32910, 32654	止ネジ	3
27	1174	Screw for 32911 (32910)	上メス抱キ止ネジ	1
28	5508	Screw for 32914	上メス止ネジ	1
29	32912	Upper Knife Holder Guide	上メス案内	1
30	7616	Screw for 32912	上メス案内止ネジ	1
31	723	Guide Pin for 32912	上メス案内ピン	1
32	32909	Upper Knife Driving Arm Guide	上メス台ガイド	1
33	3434	Screw for 32909	上メス台ガイド止ネジ	1
34	32519	Upper Knife Driving Arm Guide Plug	上メス台ガイド詰栓	1
35	32903	Upper Knife Driving Shaft	上メス軸	1
36	32902	Upper Knife Driving Lever	上メス軸腕	1
37	32920	Upper Knife Driving Shaft Collar (Left)	上メス軸カラー(左)	1
38	7311	Screw for 32920	上メス軸カラー(左)止ネジ	1
39	32900	Upper Knife Driving Connecting Rod	上メスロット	1
40	32666	Throat Plate #1	針板 #1	1
40-1	32667	Throat Plate #2	針板 #2	1
40-2	32682	Throat Plate #3	針板 #3	1
41	5401	Screw for Throat Plate	針板止ネジ	1
42	32655	Needle Guard (Front)	針受ケ(前)	1
43	4404	Screw for 32655	針受ケ(前)止ネジ	1
44	32601	Throat Plate Supporter	針板受ケ	1
45	6662	Screws for 32601	針板受ケ止ネジ	2
46	32604	Cloth Plate Rubber Cushion	埋メ座(大)	1
47	32916	Lower Knife Holder	下メス台	1
48	4591	Screw for 32916	下メス台止ネジ	1
49	32919	Lower Knife Holder Spring	下メスバネ	1
50	5074	Screw for 32919	下メスバネ止ネジ	1
51	30421	Lower Knife	下メス	1
52	32917	Lower Knife Clamp	下メス押シ	1
53	7605	Screw for 32917	下メス押シ止ネジ	1
54	37654	Needle Guard (Rear)	針受ケ(後)	1
55	32899	Lower Knife Holder Locking Plate	下メス台廻り止メ	1
56	4440	Screws for 32899	下メス台廻り止メ止ネジ	2

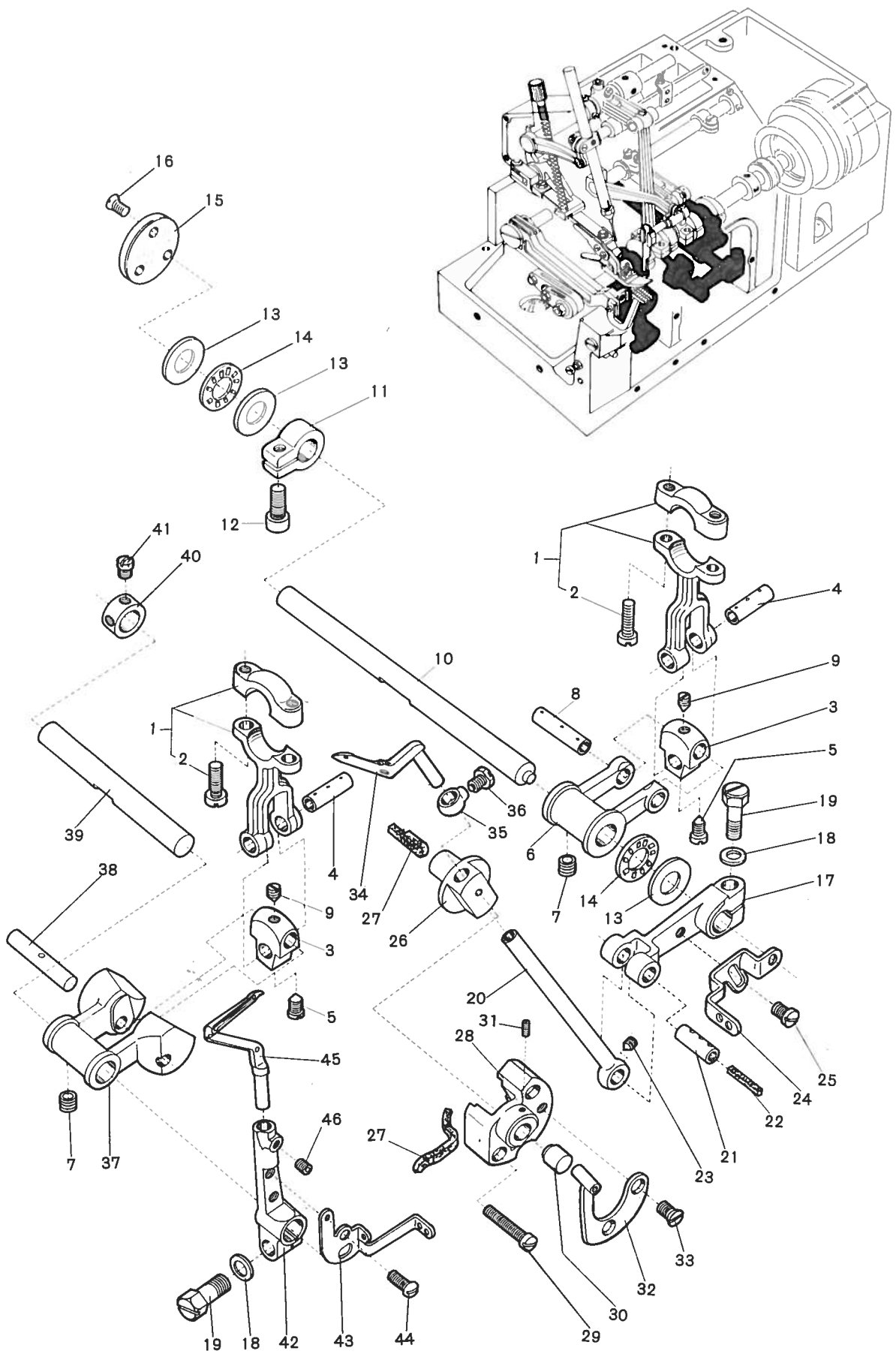

Ref. No.	Parts No.	Description	品名	Amt. Req.
1	32783	Looper Driving Lever Connecting Rods	ルーパーロッド	2
2	5071	Screws for 32783	ルーパーロッドキャップ止ネジ	4
3	32785	Looper Driving Lever Links	ルーパーリンク	2
4	32784	Looper Driving Lever Link Pins (Short)	ルーパーリンクピン(短)	2
5	9506	Screws for 32784	ルーパーリンクピン(短)止ネジ	2
6	32787	Upper Looper Driving Lever	ルーパー軸腕	1
7	3635	Screws for 32787, 32815	止ネジ	4
8	32786	Looper Driving Lever Link Pin (Long)	ルーパーリンクピン(長)	1
9	3404	Screws for 32786, 32816	止ネジ	2
10	34517	Upper Looper Driving Shaft	上ルーパー軸	1
11	32792	Upper Looper Driving Shaft Collar	上ルーパー軸カラー	1
12	5550	Screw for 32792	上ルーパー軸カラー止ネジ	1
13	32848	Upper Looper Driving Shaft Thrust Washers	スラストプレート	3
14	32849	Upper Looper Driving Shaft Thrust Rollers	スラストコロ	2
15	33013	Upper Looper Driving Shaft End Cap	上ルーパー軸蓋	1
16	5345	Screws for 33013	上ルーパー軸蓋止ネジ	3
17	34104	Upper Looper Bar Driving Arm	上ルーパークランク	1
18	520	Washers for 34104, 32789	座金	2
19	5500	Screws for 34104, 32789	止ネジ	2
20	32800	Upper Looper Bar	ルーパー棒	1
21	32799	Upper Looper Bar Driving Arm Pin	ルーパークランクピン	1
22	282	Oil Wick for 32799	ルーパークランクピン油芯	1
23	3311	Screw for 32799	ルーパークランクピン止ネジ	1
24	34224	Looper Thread Pull-Off (Right)	ルーパー糸繰り(右)	1
25	4358	Screw for 34224	ルーパー糸繰り(右)止ネジ	1
26	32347	Upper Looper Bar Guide	ルーパー案内	1
27	304	Oil Wicks for 32347, 32800	油芯	2
28	34516	Upper Looper Bar Guide Retainer	ルーパー案内蓋	1
29	5004	Screws for 34516	ルーパー案内蓋止ネジ	2
30	32348	Upper Looper Bar Guide Thrust Pin	ルーパー案内決メピン	1
31	7650	Screw for 32348	ルーパー案内決メピン止ネジ	1
32	34226	Upper Looper Thread Guide	上ルーパー糸道	1
33	9142	Screws for 34226	上ルーパー糸道止ネジ	2
34	32807	Upper Looper	上ルーパー	1
35	32803	Upper Looper Holder Collar	上ルーパー止メカラー	1
36	5507	Screw for 32803	上ルーパー止メカラー止ネジ	1
37	32815	Lower Looper Driving Lever	下ルーパー軸腕	1
38	32816	Lower Looper Driving Lever Pin	下ルーパー軸腕ピン	1
39	32788	Lower Looper Driving Shaft	下ルーパー軸	1
40	30228	Lower Looper Shaft Collar	下ルーパー軸カラー	1
41	9604	Screws for 30228	下ルーパー軸カラー止ネジ	2
42	32789	Lower Looper Holder Arm	下ルーパー台	1
43	32959	Looper Thread Pull-Off (Left)	ルーパー糸繰り(左)	1
44	1326	Screws for 32959	ルーパー糸繰り(左)止ネジ	2
45	32790	Lower Looper	下ルーパー	1
46	3638	Screw for 32790	下ルーパー止ネジ	1

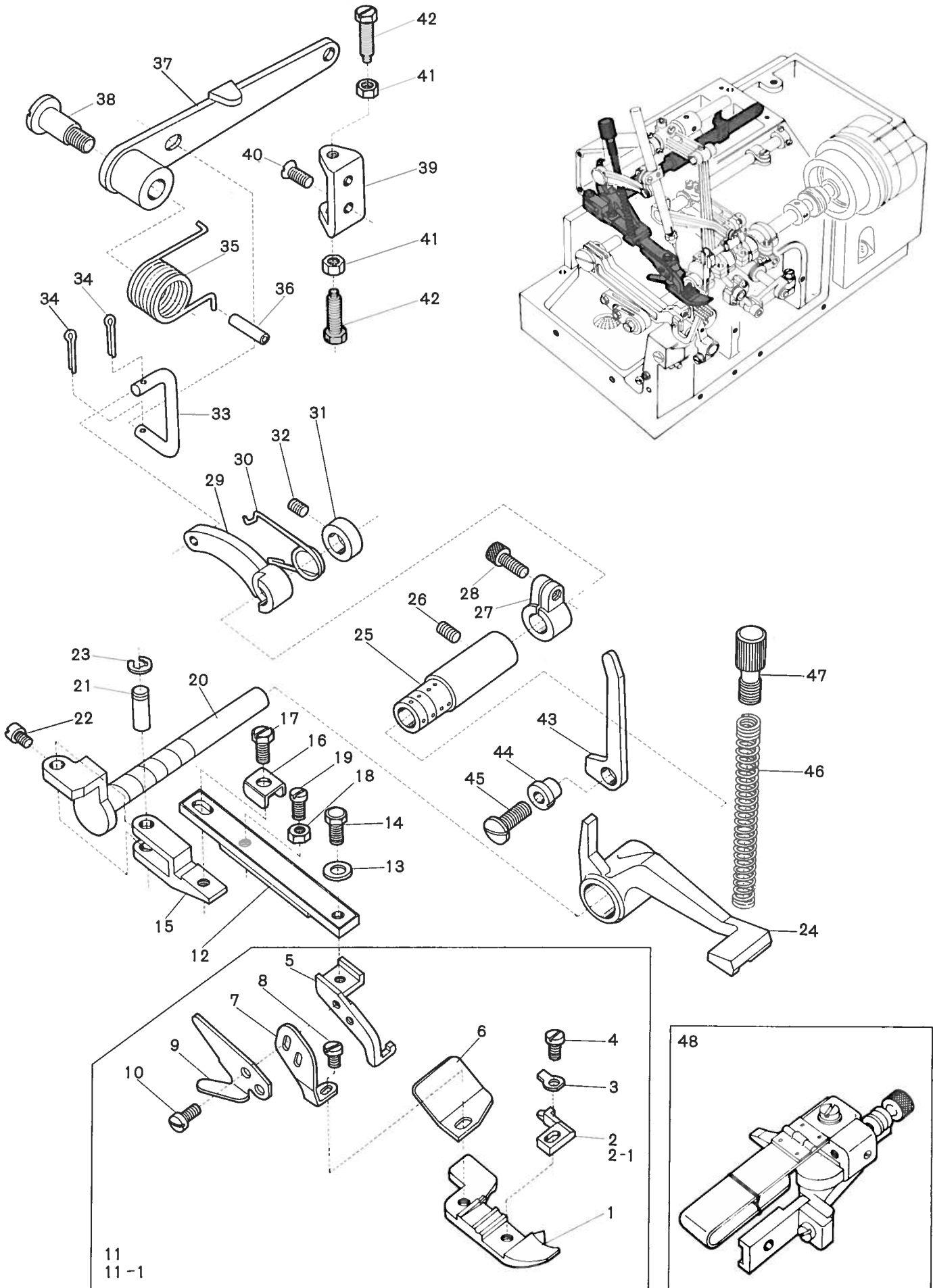

11
11-1

48

Ref. No.	Parts No.	Description	品名	Amt. Req.
1	32736	Presser Foot	押工(下)	1
2	32744	Presser Foot Stitch Tongue #1	爪 #1	1
2-1	32743	Presser Foot Stitch Tongue #2, #3	爪 #2, #3	1
3	30619	Presser Foot Hinge Spring	押工ヒンジバネ	1
4	5036	Screw for Stitch Tongue	爪止ネジ	1
5	32741	Presser Foot Holder	押工(上)	1
6	34535	Presser Foot Chain Shield	空糸押工	1
7	34536	Presser Foot Stay	押工固定片	1
8	1230	Screw for 34536	押工固定片止ネジ	1
9	32706	Chain Cutting Knife	チェンカッター	1
10	4404	Screws for 32706	チェンカッター止ネジ	2
11	32735	Presser Foot Complete Set #1	押工(組) #1	1
11-1	32734	Presser Foot Complete Set #2, #3	押工(組) #2, #3	1
12	32725	Foot Carrier	押工取付板	1
13	538	Washer for 5509	座金	1
14	5509	Screw for Presser Foot	押工止ネジ	1
15	32724	Foot Carrier Hinge	押工台	1
16	32728	Foot Carrier Washer	押工台座金	1
17	5541	Screw for 32725	押工取付板止ネジ	1
18	335	Nut for 4357	押工揚ゲストッパーネジナット	1
19	4357	Stop Screw for Presser Foot	押工揚ゲストッパーネジ	1
20	32722	Foot Lifter Lever Shaft	押工軸	1
21	32723	Foot Lifter Hinge Pin	押工ヒンジピン	1
22	1186	Screw for 32723	押工ヒンジピン止ネジ	1
23	33024	Foot Lifter Hinge Pin Retaining Ring	ヒンジピンストップリング	1
24	32721	Presser Foot Positioning Arm	押工位置決レバー	1
25	32720	Foot Lifter Bushing	押工軸ブッシュ	1
26	2022	Screw for 32720	押工軸ブッシュ止ネジ	1
27	32718	Foot Lifter Latch Collar	押工軸レバーカラー	1
28	5550	Screw for 32718	押工軸レバーカラー止ネジ	1
29	32717	Intermediate Lever	押工軸レバー	1
30	32729	Intermediate Lever Spring	押工軸バネ	1
31	32719	Foot Lifter Small Collar	押工軸レバーカラー	1
32	1459	Screw for 32719	押工軸レバー止カラー止ネジ	1
33	32714	Foot Lifter Lever Connecting Link	押工レバー連結桿	1
34	32715	Cotter Pins	割ピン	2
35	32713	Foot Lifter Lever Spring	押工揚ゲレバーバネ	1
36	690	Latch Pin for 32713	バネ掛ケピン	1
37	32711	Foot Lifter Lever	押工揚ゲレバー	1
38	6000	Screw for 32711	押工揚ゲレバー止ネジ	1
39	32716	Foot Lifter Lever Stopper	押工揚ゲストッパー	1
40	9127	Screws for 32716	押工揚ゲストッパー止ネジ	2
41	334	Nuts for 32711	押工揚ゲストッパー調節ネジナット	2
42	5505	Adjust Screws for 32711	押工揚ゲストッパー調節ネジ	2
43	32727	Presser Foot Release Lever	手揚ゲ	1
44	32420	Presser Foot Release Lever Bushing	手揚ゲブッシュ	1
45	4635	Screw for 32420	手揚ゲブッシュ止ネジ	1
46	32726	Presser Spring	押工バネ	1
47	6401	Presser Spring Adjusting Screw	押工調節ネジ	1
48	37966	Hemming Guide Complete Set for DCZ-200 Only	スノ引定規(組)	1

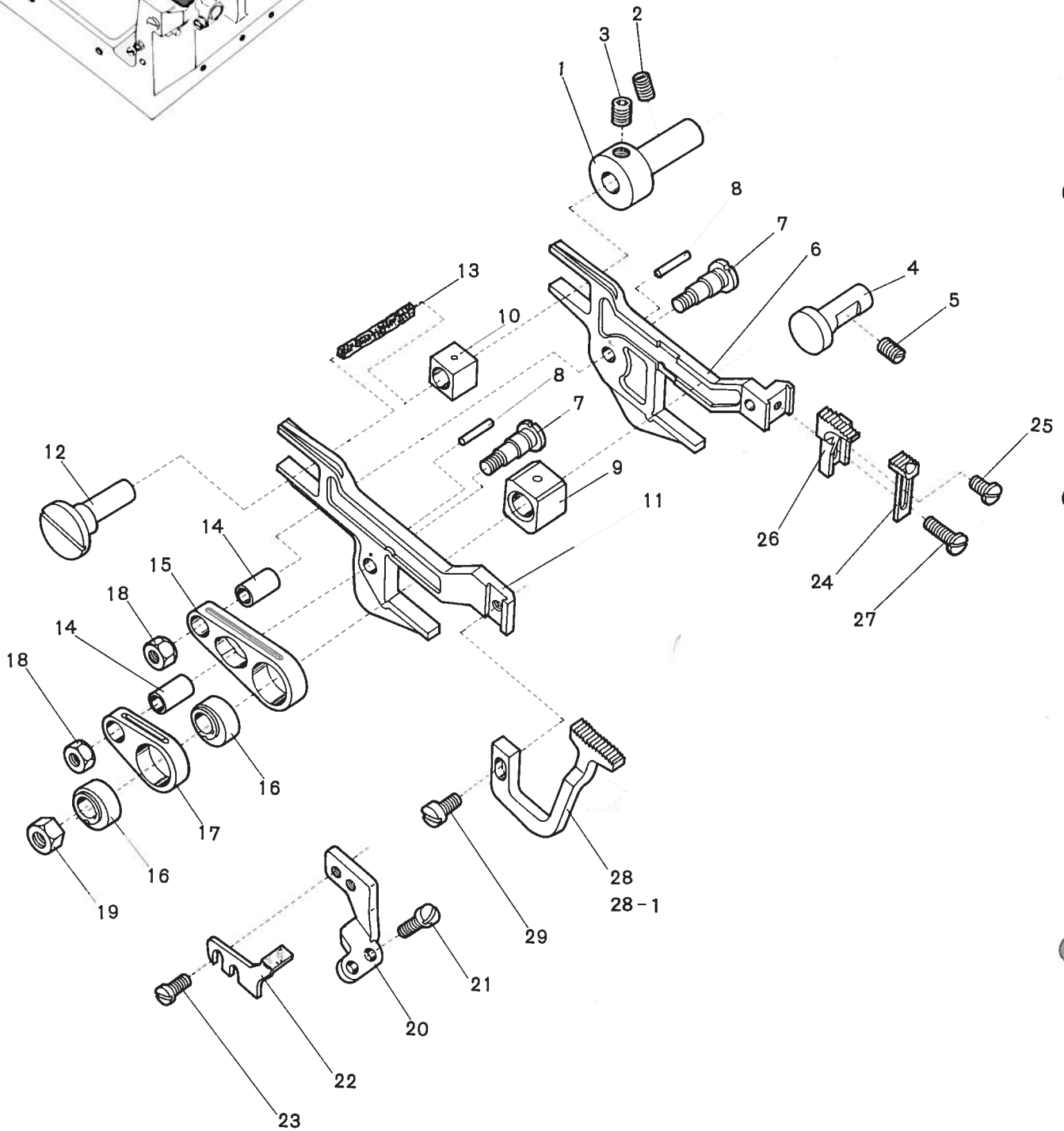
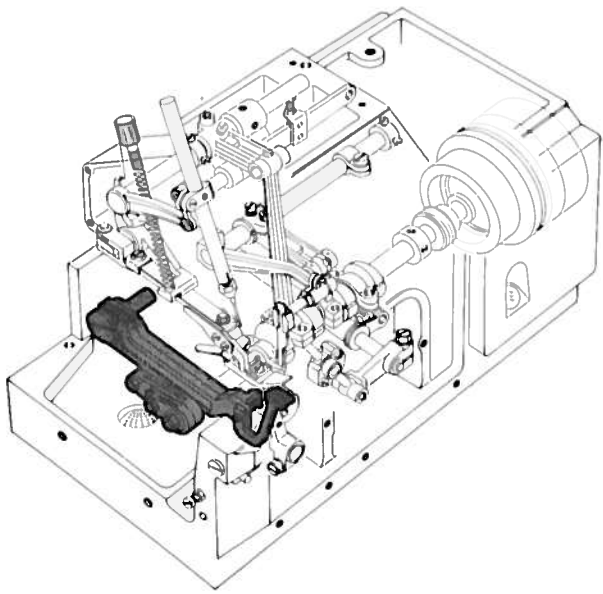

<u>Ref. No.</u>	<u>Parts No.</u>	<u>Description</u>	<u>品名</u>	<u>Amt. Req.</u>
1	34134	Feed Bar Guide (Rear)	送り台ガイド(後)	1
2	3632	Screw for 34134	送り台ガイド(後)止ネジ	1
3	3635	Screw for 32866	エキセンピン止ネジ	1
4	32858	Feed Bar Guide (Right)	送り台ガイド(右)	1
5	9200	Screw for 32858	送り台ガイド(右)止ネジ	1
6	32857	Main Feed Bar	後送り台	1
7	32864	Feed Bar Driving Studs	送りリンクピン	2
8	722	Cotters for 32864	送りリンクピンノックピン	2
9	32854	Feed Lifter Block	角駒(大)	1
10	32867	Feed Bar Guide Block	角駒(小)	1
11	32856	Differential Feed Bar	前送り台	1
12	32866	Feed Adjusting Pin	エキセンピン	1
13		Oil Wick for 32866	油芯(エキセンピン)	1
14	32853	Feed Bar Driving Connection Bushings	送りリンクブッシュ	2
15	32852	Main Feed Bar Driving Connection	後送りリンク	1
16		Feed Driving Eccentrics (See Below The Table)	送り前後エキセン	2
17	32851	Differential Feed Bar Driving Connection	前送りリンク	1
18	451	Nuts for 32864	送りリンクピンネジナット	2
19	20	Nut for Feed Driving Eccentric	送り前後エキセンナット	1
20	32381	Feed Bar Guide (Left)	送り台ガイド(左)	1
21	4440	Screws for 32381	送り台ガイド(左)止ネジ	2
22	34059	Throat Plate Stay	針板支工	1
23	5000	Screws for 34059	針板支工止ネジ	2
24	32883	Chaining Feed Dog	小送り	1
25	9730	Screw for Chaining Feed Dog	小送り止ネジ	1
26	33811	Main Feed Dog	後送り	1
27	7609	Screw for Main Feed Dog	後送り止ネジ	1
28	33810	Differential Feed Dog (Standard)	前送り	1
28-1	33812	Differential Feed Dog(Coarse Mesh)	前送り(並目)	1
29	4353	Screw for Differential Feed Dog	前送り止ネジ	1

Feed Driving Eccentrics Table

<u>PARTS No.</u>	<u>STITCHES PER INCH</u>
32821	5
32822	6
32835	7
32823	8
32824	9
32825	10
32836	11
32826	12
32827	13
32828	14
32837	15
32838	16
32829	17
32839	18
32830	19
32840	20
32841	22
32842	24
32832	26
32843	28
32844	30
32845	40
32833	50
32846	70
32847	100

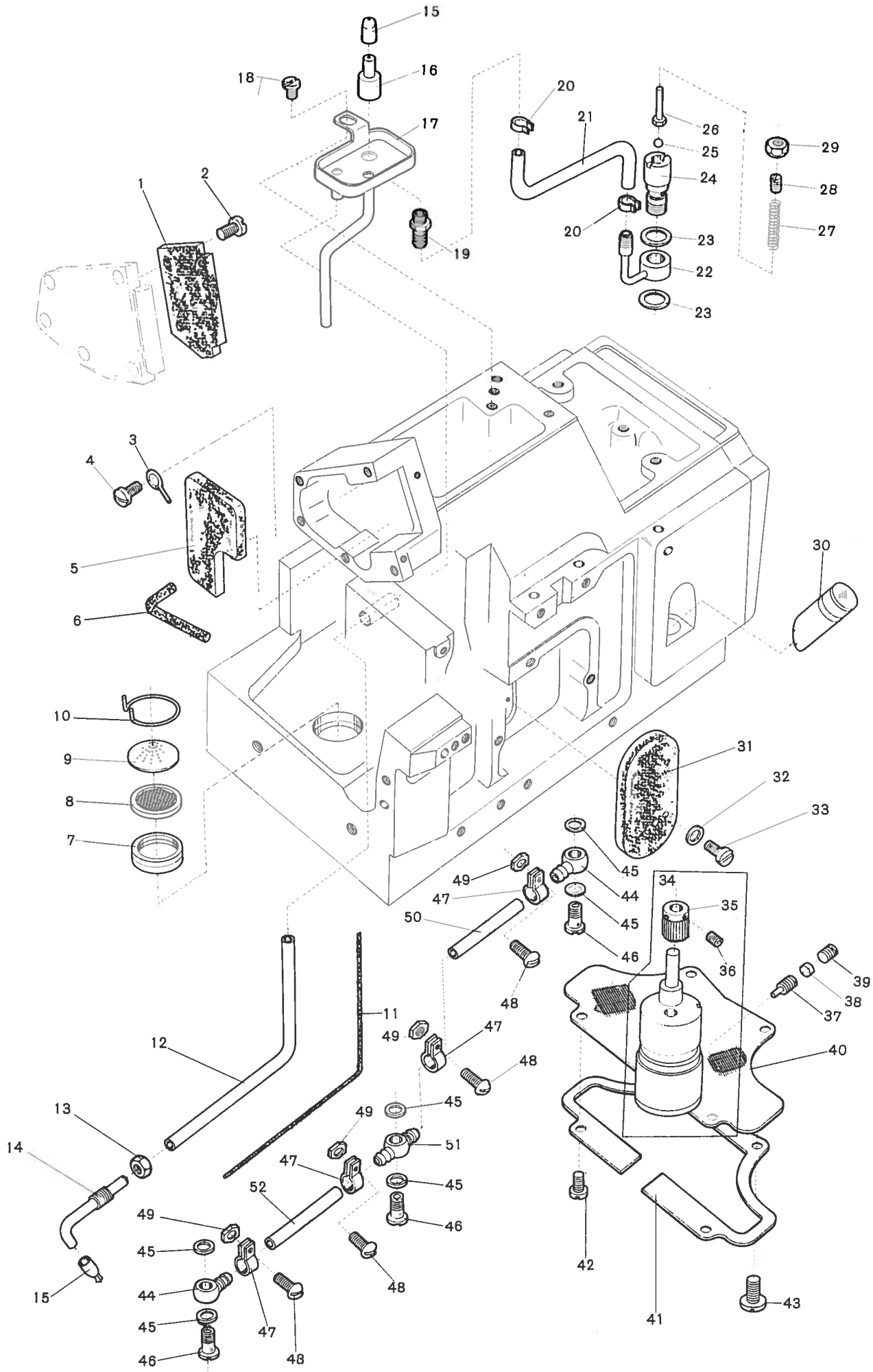

Ref. No.	Parts No.	Description	品名	Amt. Req.
1	32685	Needle Bar Oiling Felt (Left)	針棒フェルト(左)	1
2	9853	Screws for 32685	針棒フェルト(左)止ネジ	2
3	32812	Needle Bar Oiling Felt Retainer	フェルト押工	1
4	9604	Screw for 32812	フェルト押工止ネジ	1
5	32649	Needle Bar Oiling Felt (Right)	針棒フェルト(右)	1
6	—	Oil Wick for Needle Bar Connection Link	針棒リンクフェルト油芯	1
7	32934	Round Oil Filter Holder Ring	汙過網受ケ	1
8	32931	Round Oil Filter Screen (Fine Mesh)	汙過網(細目)	1
9	32933	Round Oil Filter Screen (Coarse Mesh)	汙過網(荒目)	1
10	32898	Round Oil Filter Screen Clamp	汙過網押工(小)	1
11	—	Oil Wick for Feed Driving Eccentric	オイルパイプ油芯	1
12	32483	Feed Bar Driving Connection Oil Tube	送りリンク注油パイプ(220mm)	1
13	419	Nut for 32480	オイルパイプナット	1
14	32480	Feed Bar Driving Connection Oil Nozzle	オイルパイプ	1
15	37697	Oil Nozzle Caps	注油キャップ	2
16	32479	Oil Sight Top Nozzle	ノズル	1
17	32476	Oil Receiver	油受ケ皿(組)	1
18	9604	Screw for 32476	油受ケ皿止ネジ	1
19	9909	Oil Tube Fitting Nut	管継手ナット	1
20	37675	Oil Tube Clamps (Small)	緊束環(小)	2
21	32850	Oil Tube 150	オイルチューブ(150 mm)	1
22	32376	Oil Relief Valve Fitting Tube	調圧管取付台	1
23	509	Seals for 32376	調圧管取付台パッキン	2
24	32938	Oil Relief Valve	調圧弁座	1
25	80503	Oil Relief Ball	調圧ボール弁	1
26	30748	Oil Relief Valve Spring Guide	調圧弁バネ案内ピン	1
27	30745	Oil Relief Valve Spring	調圧弁バネ	1
28	6861	Adjust Screw for 30745	調圧弁バネ調節ネジ	1
29	419	Nut for 30745	調圧弁調節ネジナット	1
30	32417	Oil Sight Gauge	オイルゲージ	1
31	32806	Upper Looper Bar Oiling Felt	ルーバーフェルト	1
32	550	Washers for 32806	ルーバーフェルト止ネジ座金	2
33	4353	Screws for 32806	ルーバーフェルト止ネジ	2
34	32929	Oil Pump Complete Set	ポンプ(組)	1
35	30711	Oil Pump Driving Worm Gear	ウォームギヤー	1
36	1459	Screws for 30711	ウォームギヤー止ネジ	2
37	6330	Screw for 32929	ポンプ止ネジ	1
38	926	Seal for 32929	蓋ネジパッキン	1
39	9503	Screw for 32929	蓋ネジ	1
40	32935	Under Pump Oil Filter Screen	汙過網(大)(細目)	1
41	32937	Under Pump Oil Filter Screen Clamp	汙過網押工(大)	1
42	4358	Screws for 32937	汙過網押工(大)止ネジ	2
43	4351	Screws for 32937	汙過網押工(大)止ネジ	2
44	37669	Oil Tube Fittings One Way End	片口管継手	2
45	567	Seals for 37668, 37669	管継手パッキン	6
46	7668	Oil Tube Fitting Studs	管継手ボルト	3
47	32944	Oil Tube Clamps	緊束環(大)	4
48	5133	Screws for 32944	緊束環止ネジ	4
49	331	Nuts for 32944	緊束環止ネジナット	4
50	32948	Oil Tube 47	オイルパイプ(47mm)	1
51	37668	Oil Tube Fitting Two Way End	両口管継手	1
52	32949	Oil Tube 58	オイルパイプ(58mm)	1

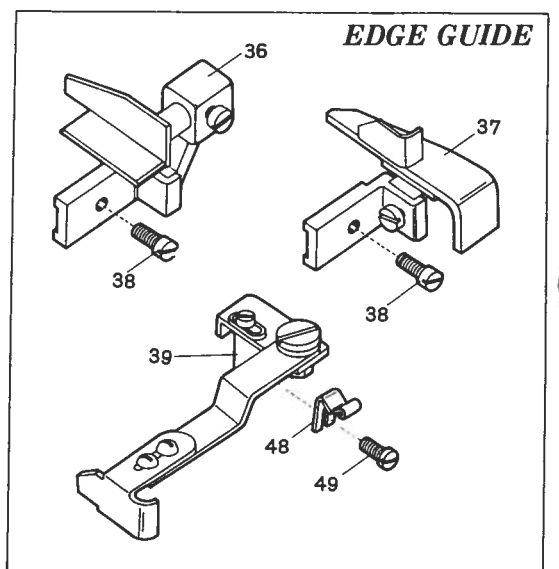
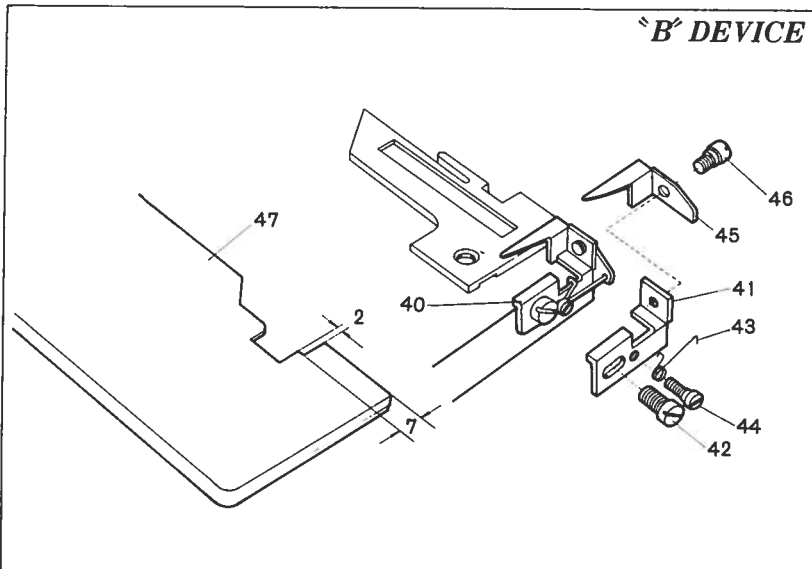
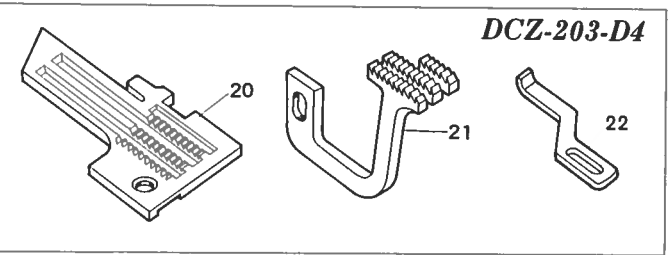
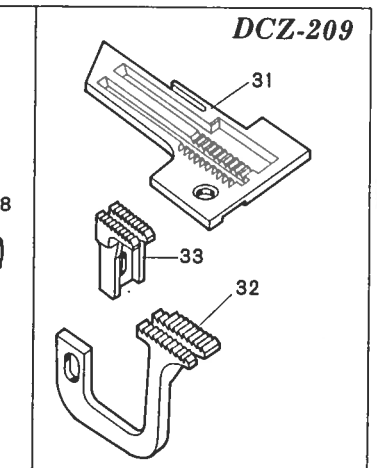
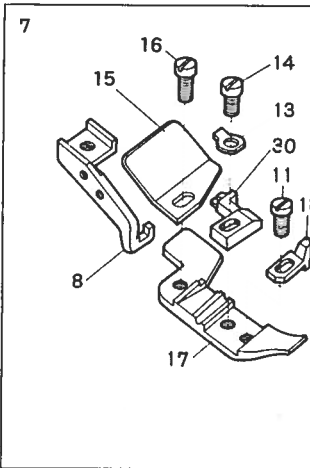
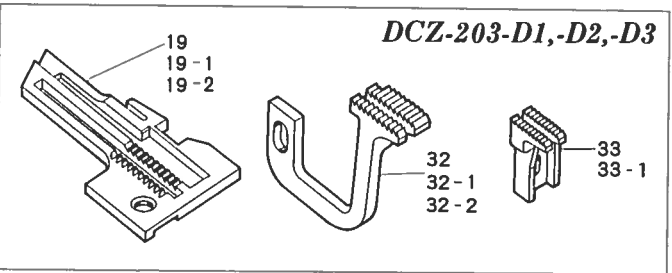
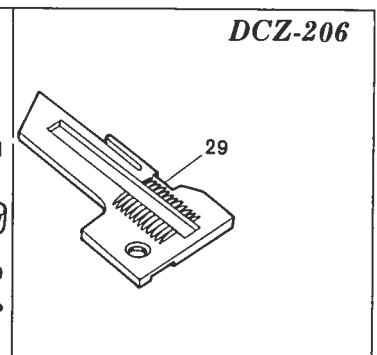
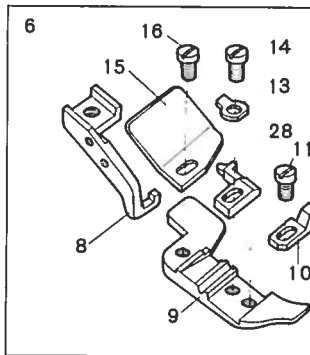
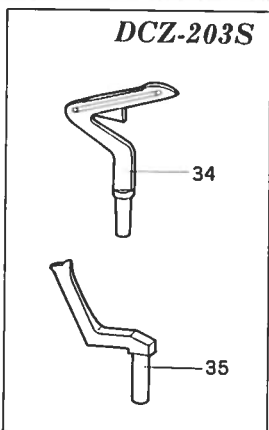
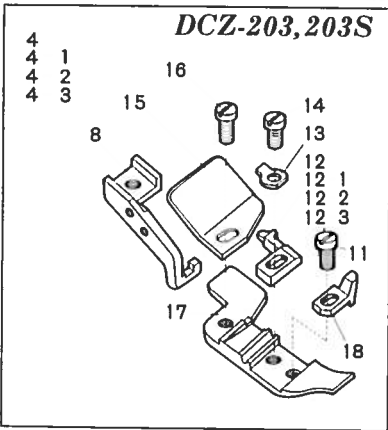
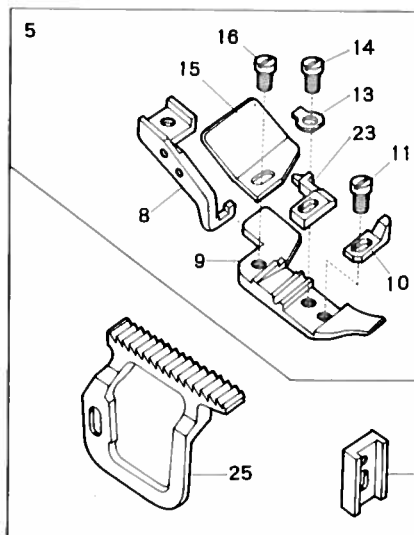
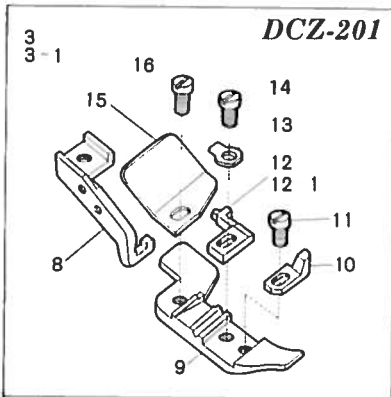
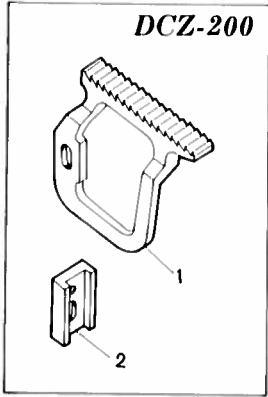

DCZ-200,-201,-203S,-205,-206,-209 EXCLUSIVE PARTS サブクラス専用部品 10

Ref. No.	Parts No.	Description	品 名	Amt. Req.
1	32871	Plain Feed Dog for DCZ-200	送り P (DCZ-200)	1
2	32873	Chaining Feed Dog Holder for DCZ-200	小送り取付片 (DCZ-200)	1
3	32738	Presser Foot Complete Set #1 for DCZ-201	押工 (組) (DCZ-201 #1)	1
3-1	32739	Presser Foot Complete Set #2, #3 for DCZ-201	押工 (組) (DCZ-201 #2 #3)	1
4	32747	Presser Foot Complete Set #1 for DCZ-203	押工 (組) (DCZ-203 #1)	1
4-1	32748	Presser Foot Complete Set #2, #3 for DCZ-203	押工 (組) (DCZ-203 #2 #3)	1
4-2	32394	Presser Foot Complete Set #4 for DCZ-203	押工 (組) (DCZ-203 #4)	1
4-3	32757	Presser Foot Complete Set for DCZ-203S	押工 (組) (DCZ-203S)	1
5	32755	Presser Foot Complete Set for DCZ-205	押工 (組) (DCZ-205)	1
6	32731	Presser Foot Complete Set for DCZ-206	押工 (組) (DCZ-206)	1
7	33447	Presser Foot Complete Set for DCZ-209	押工 (組) (DCZ-209)	1
8	32741	Presser Foot Holder	押工 (上)	1
9	32740	Presser Foot	押工 (下)	1
10	32745	Presser Foot Chip Guard	押工チップ	1
11	1230	Screw for 32745	押工チップ止ネジ	1
12	32744	Presser Foot Stitch Tongue #1	爪 #1	1
12-1	32743	Presser Foot Stitch Tongue #2, #3	爪 #2, #3	1
12-2	32495	Presser Foot Stitch Tongue #4	爪 #4	1
12-3	32759	Presser Foot Stitch Tongue for DCZ-203S	爪 (DCZ-203S)	1
13	30619	Presser Foot Hinge Spring	押工ヒンジバネ	1
14	5036	Screw for Stitch Tongue	爪止ネジ	1
15	34535	Presser Foot Chain Shield	空糸押工	1
16	1228	Screw for 34535	空糸押工止ネジ	1
17	32708	Presser Foot	押工 (下)	1
18	32710	Presser Foot Chip Guard	押工チップ	1
19	32671	Throat Plate #1 for DCZ-203	針板 #1 (DCZ-203)	1
19-1	32672	Throat Plate #2 for DCZ-203	針板 #2 (DCZ-203)	1
19-2	32673	Throat Plate #3 for DCZ-203	針板 #3 (DCZ-203)	1
20	34258	Throat Plate #4 for DCZ-203	針板 #4 (DCZ-203)	1
21	33815	Differential Feed Dog for DCZ-203-D4	前送り (DCZ-203-D4)	1
22	32544	Needle Guard (Front) for DCZ-203-D4	針受 (前) (DCZ-203-D4)	1
23	32754	Presser Foot Stitch Tongue for DCZ-205	爪 (DCZ-205)	1
24	32668	Throat Plate for DCZ-205	針板 (DCZ-205)	1
25	32892	Plain Feed Dog for DCZ-205	送り P (DCZ-205)	1
26	32893	Chaining Feed Dog for DCZ-205	小送り (DCZ-205)	1
28	32732	Presser Foot Stitch Tongue for DCZ-206	爪 (DCZ-206)	1
29	32669	Throat Plate for DCZ-206	針板 (DCZ-206)	1
30	33448	Presser Foot Stitch Tongue for DCZ-209	爪 (DCZ-209)	1
31	33449	Throat Plate for DCZ-209	針板 (DCZ-209)	1
32	33813	Differential Feed Dog for DCZ-203(Standard)	前送り (DCZ-203)	1
32-1	33816	Differential Feed Dog (Coarse Mesh)	前送り (並目)	1
32-2	33817	Differential Feed Dog (Large Teeth)	前送り (荒歯)	1
33	33814	Main Feed Dog for DCZ-203	後送り (DCZ-203)	1
33-1	33818	Main Feed Dog (Large Teeth)	後送り (荒歯)	1
34	32336	Lower Looper for DCZ-203S	下ルーバー (DCZ-203S)	1
35	32813	Spreader for Two Thread Seaming	上スプレダー	1
36	37948	Edge Guide Complete Set (Large)	当定規 (組) (大)	1
37	37962	Edge Guide Complete Set (Small)	当定規 (組) (小)	1
38	4358	Screw for 37948, 37962	当定規止ネジ	1
39	33751	Edge Guide Complete Set (Swing)	当定規 (横開キ式)	1
40	33761	Bar Tacking Knife Complete Set	返し縫ナイフ (組)	1
41	33759	Bar Tacking Set Holder	返し縫ナイフ取付台	1
42	4353	Screw for 33759	返し縫ナイフ取付台止ネジ	1
43	33760	Spring for Bar Tacking	返し縫バネ	1
44	5518	Screw for 33760	返し縫バネ止ネジ	1
45	33758	Bar Tacking Knife	返し縫ナイフ	1
46	5517	Screw for 33758	返し縫ナイフ止ネジ	1
47	33762	Cloth Plate (Upper)	大カバー	1
48	33400	Front Cover Latch Spring	前開キカバーバネ	1
49	7405	Screw for 33400	前開キカバー止ネジ	1

DCZ-220
DCZ-220W
DCZ-221

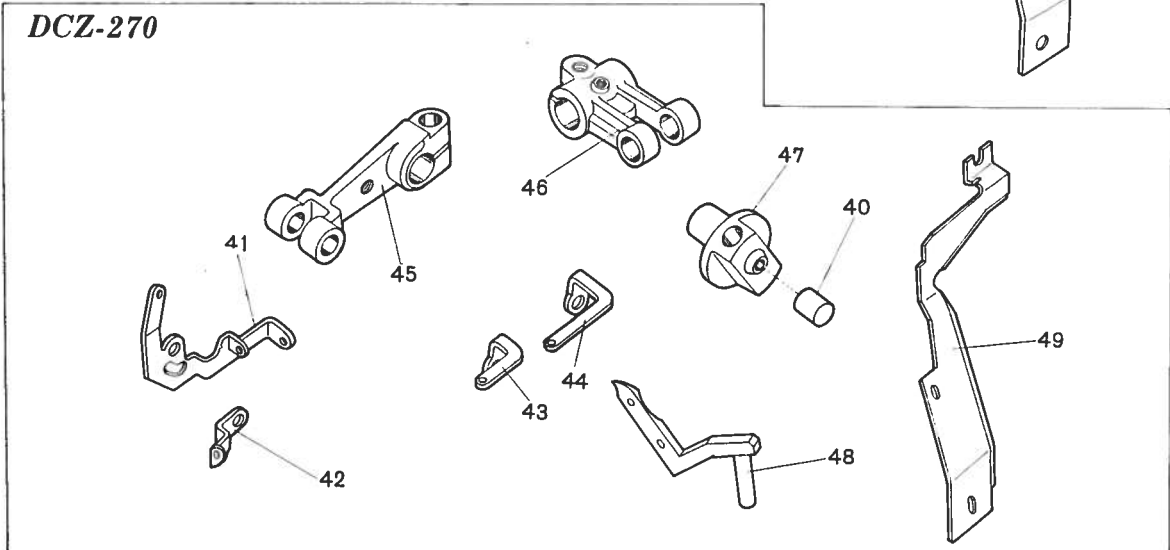
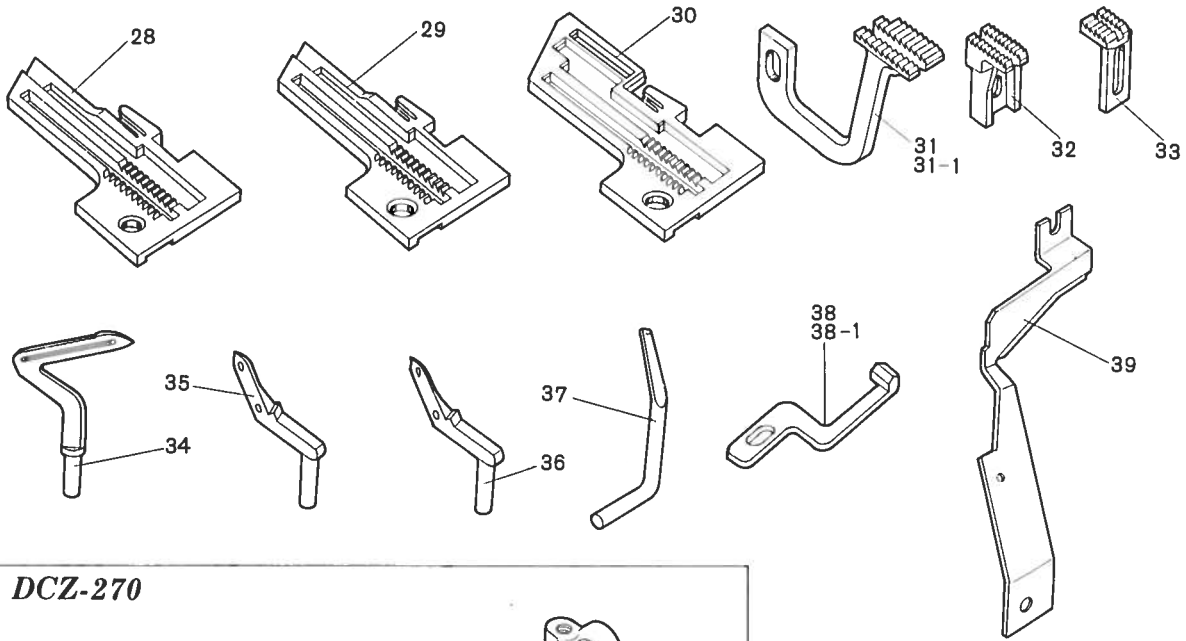
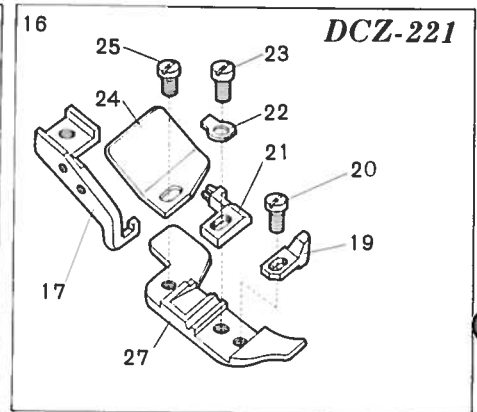
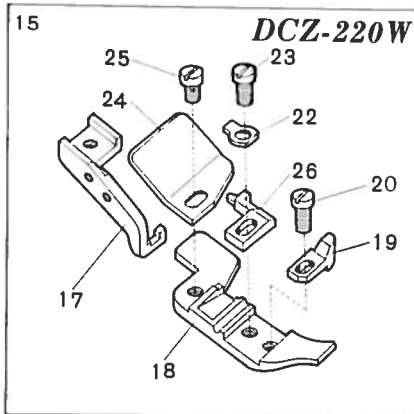
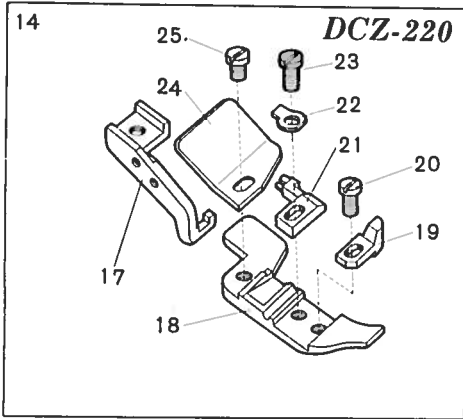
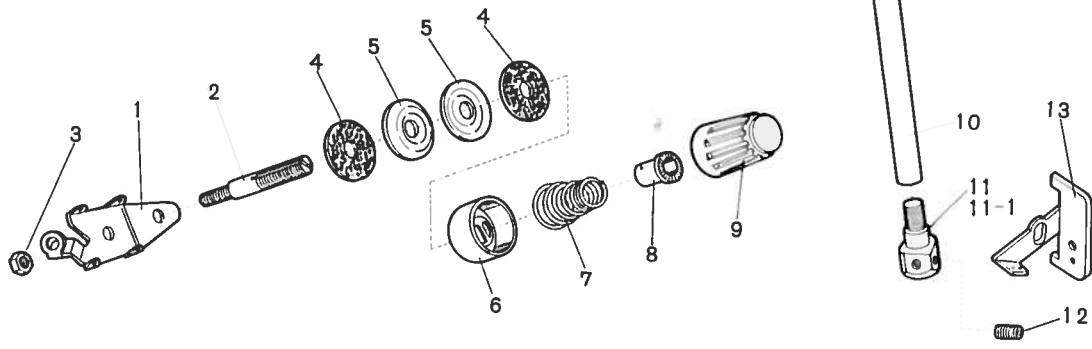

DCZ-220, -220W, -221, -270 EXCLUSIVE PARTS サブクラス専用部品 11

Ref. No.	Parts No.	Description	品名	Amt. Req.
1	32968	Needle Thread Tension Disc Eyelet	調子台糸道	1
2	6543	Tension Post	糸調子棒	1
3	340	Nut for 6543	糸調子棒止ナット	1
4	286	Felts for 01111	フェルト	8
5	01111	Tension Discs	糸調子皿	8
6	37635	Thread Tension Spring Retainers	渦巻キバネキャップ(下)	4
7	32971	Needle Thread Tension Springs	渦巻キバネ(太)	2
8	30254	Tension Spring Bushings	糸調子ナット廻り止メ	4
9	32965	Thread Tension Spring Cap	渦巻バネキャップ(上)	4
10	37372	Needle Bar	針棒	1
11	37373	Needle Holder for DCZ-220, -221	針止メ(DCZ-220, -221)	1
11-1	37894	Needle Holder for DCZ-220W	針止メ(DCZ-220W)	1
12	3637	Screws for Needle	針止ネジ	2
13	32427	Needle Thread Eyelet	針糸道	1
14	32750	Presser Foot Complete Set for DCZ-220	押工(組)(DCZ-220)	1
15	32760	Presser Foot Complete Set for DCZ-220W	押工(組)(DCZ-220W)	1
16	32343	Presser Foot Complete Set for DCZ-221	押工(組)(DCZ-221)	1
17	32741	Presser Foot Holder	押工(上)	1
18	32708	Presser Foot for DCZ-220, -220W	押工(下)(DCZ-220, -220W)	1
19	32710	Presser Foot Chip Guard	押工チップ	1
20	1230	Screw for 32710	押工チップ止ネジ	1
21	32749	Presser Foot Stitch Tongue for DCZ-220, -221	爪(DCZ-220, -221)	1
22	30619	Presser Foot Hinge Spring	押工ヒンジバネ	1
23	5036	Screw for 30619	押工ヒンジバネ止ネジ	1
24	34535	Presser Foot Chain Shield	空糸押工	1
25	1228	Screw for 34535	空糸押工止ネジ	1
26	32761	Presser Foot Stitch Tongue for DCZ-220W	爪(DCZ-220W)	1
27	32342	Presser Foot for DCZ-221	押工(下)(DCZ-221)	1
28	32677	Throat Plate for DCZ-220	針板(DCZ-220)	1
29	32678	Throat Plate for DCZ-220W	針板(DCZ-220W)	1
30	32340	Throat Plate for DCZ-221	針板(DCZ-221)	1
31	33813	Differential Feed Dog (Standard)	前送り	1
31-1	33816	Differential Feed Dog for Short Stich (Coarse Mesh)	前送り(並目)	1
32	33814	Main Feed Dog	後送り	1
33	32341	Chaining Feed Dog for DCZ-221	小送り(DCZ-221)	1
34	32415	Lower Looper for DCZ-221	下ルーバー(DCZ-221)	1
35	32810	Upper Looper for DCZ-220, -220W	上ルーバー(DCZ-220, -220W)	1
36	32811	Upper Looper for DCZ-221	上ルーバー(DCZ-221)	1
37	32418	Needle Guard (Rear)	針受ケ(後)	1
38	32359	Needle Guard (Front) for DCZ-220W	針受ケ(前)(DCZ-220W)	1
38-1	32656	Needle Guard (Front) for DCZ-220, -221	針受ケ(前)(DCZ-220, -221)	1
39	32658	Chip Guard (Fix)	切屑落シ板(大)	1
40	34587	Upper Looper Bar Guide Thrust Pin	ルーバー案内決メピン	1
41	34228	Looper Thread Pull-Off (Left)	ルーバー糸繰り(左)	1
42	32960	Lower Looper Thread Eyelet	下ルーバー糸道	2
43	32958	Looper Thread Eyelet (Left)	ルーバー糸道(左)	1
44	34607	Looper Thread Eyelet (Right)	ルーバー糸道(右)	1
45	34514	Upper Looper Bar Driving Arm	上ルーバークランク	1
46	34605	Needle Bar Driving Lever	針棒クランク軸腕	1
47	34515	Upper Looper Bar Guide	ルーバー案内	1
48	34584	Upper Looper	上ルーバー	1
49	34581	Chip Guard (Fix)	切屑落シ板(大)	1

DCZ-202
DCZ-222
DCZ-223

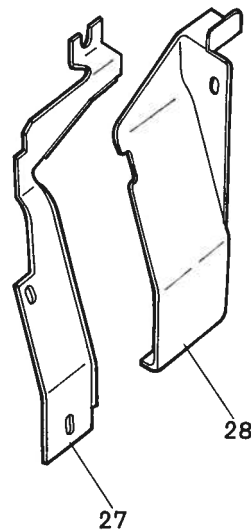
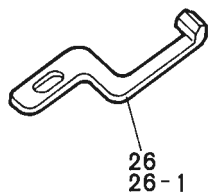
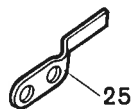
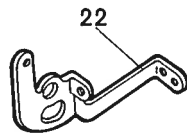
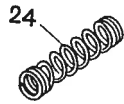
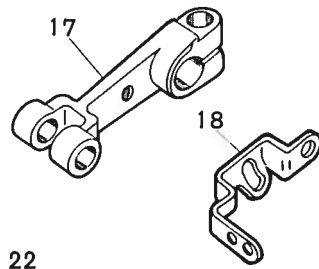
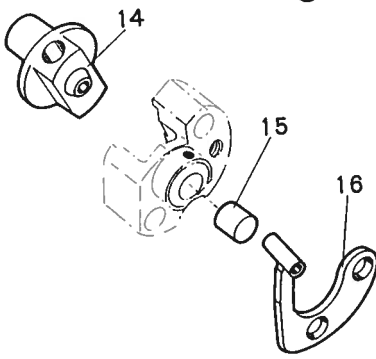
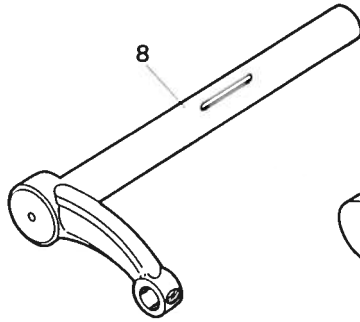
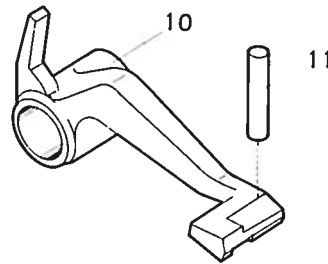
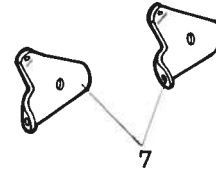
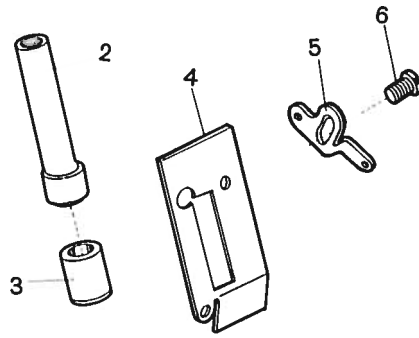
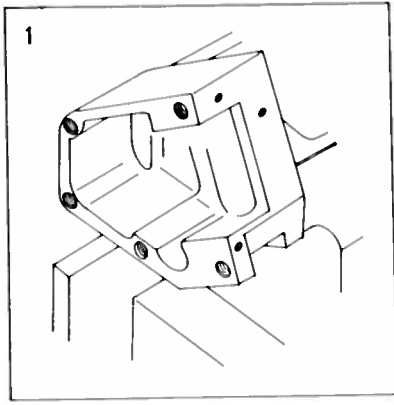

<u>Ref. No.</u>	<u>Parts No.</u>	<u>Description</u>	<u>品 名</u>	<u>Amt. Req.</u>
1	32530	Frame	ベッド.....	1
2	32532	Needle Bar Bushing (Upper).....	針棒ブッシュ(上).....	1
3	32533	Needle Bar Bushing (Lower)	針棒ブッシュ(下).....	1
4	32572	Needle Bar Connecting Link Cover.....	針棒カバー.....	1
5	32575	Auxiliary Needle Thread Eyelet	針糸道(大).....	1
6	4358	Screw for 32575	針糸道(大)止ネジ.....	1
7	32585	Looper Thread Tension Disc Eyelets	調子台糸道.....	2
8	32534	Needle Bar Driving Crank.....	針棒クランク軸.....	1
9	32556	Upper Knife Clamp.....	上メス押シ.....	1
10	32552	Presser Foot Positioning Arm	押エ位置決メレバー.....	1
11	32543	Presser Spring Guide Pin.....	押エバネピン.....	1
12	32554	Upper Knife Driving Arm Guide	上メス台案内.....	1
13	32531	Crank Shaft.....	クランクシャフト.....	1
14	34515	Upper Looper Bar Guide	ルーバー案内.....	1
15	34587	Upper Looper Bar Guide Thrust Pin.....	ルーバー案内決メピン.....	1
16	32374	Upper Looper Thread Guide.....	上ルーバー糸道.....	1
17	34514	Upper Looper Bar Driving Arm	上ルーバークランク.....	1
18	32373	Looper Thread Pull-Off (Right)	ルーバー糸繰り(右).....	1
19	32580	Looper Thread Eyelet (Right)	ルーバー糸道(右).....	1
20	32582	Looper Thread Eyelet (Left)	ルーバー糸道(左).....	1
21	32577	Looper Thread Tubes	糸道パイプ16mm.....	2
22	32583	Looper Thread Pull-Off (Left)	ルーバー糸繰り(左).....	1
23	32584	Lower Looper Thread Eyelet.....	下ルーバー糸道.....	1
24	32490	Lower Knife Holder Spring.....	下メスバネ.....	1
25	32488	Lower Knife Holder Locking Plate	下メス台廻り止メ.....	1
26	32544	Needle Guard (Front) for DCZ-202	針受ケ(前)(DCZ-202).....	1
26-1	32545	Needle Guard (Front) for DCZ-222, -223.....	針受ケ(前)(DCZ-222, -223).....	1
27	32576	Chip Guard (Fix)	切屑落シ板(大).....	1
28	32498	Chip Guard (Open)	切屑落シ板(小).....	1

DCZ-202
DCZ-222
DCZ-223

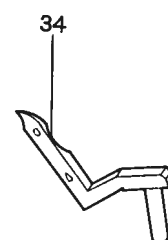
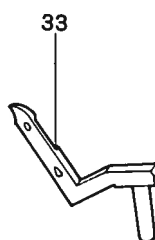
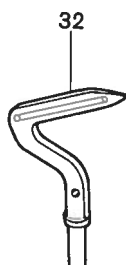
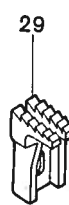
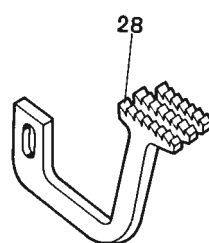
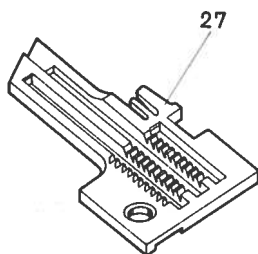
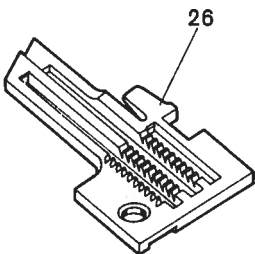
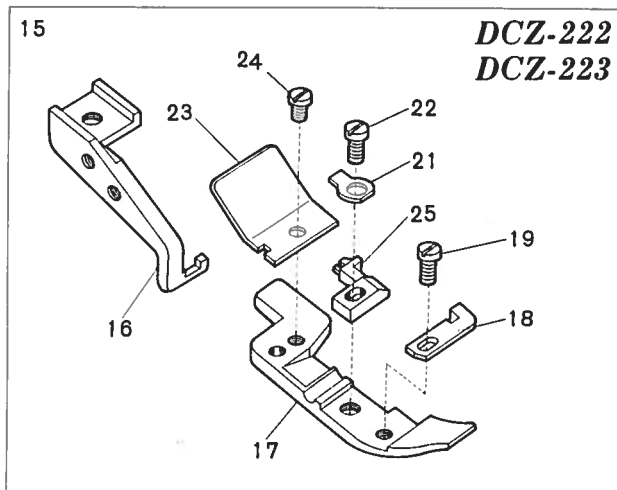
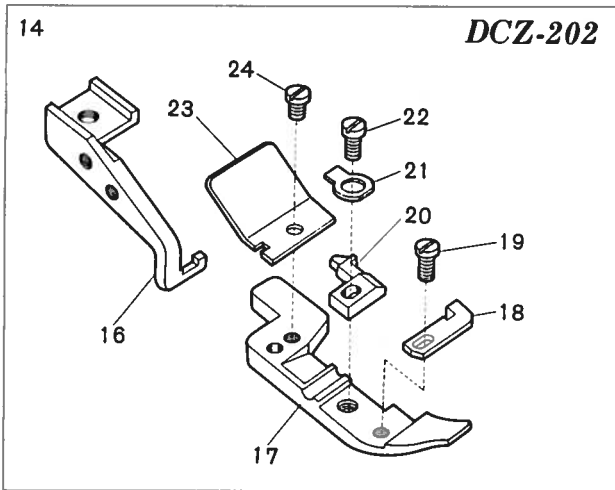
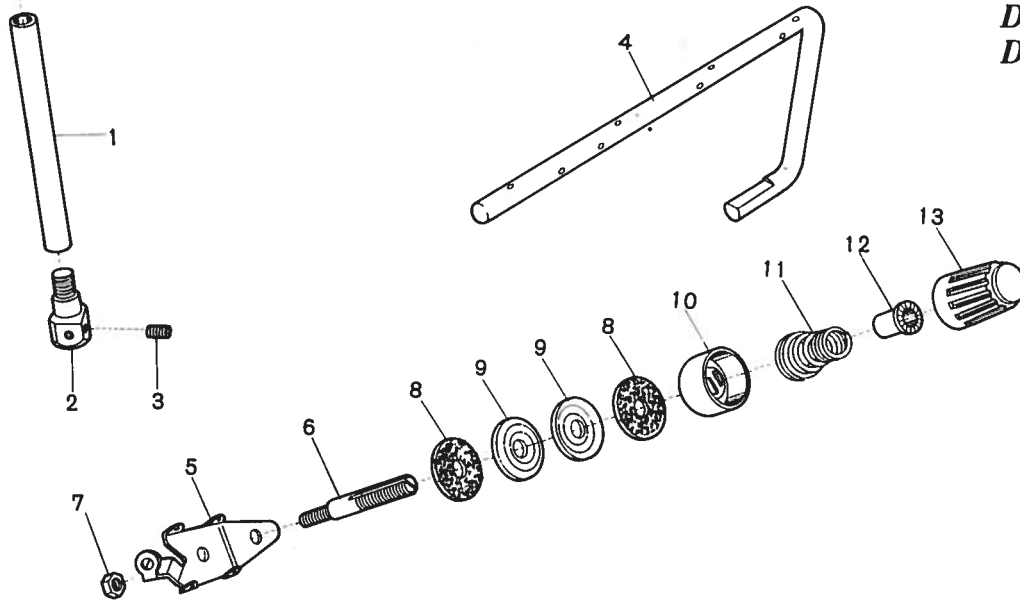

DCZ-202,-222,-223 EXCLUSIVE PARTS(2) サブクラス専用部品 13

Ref. No.	Parts No.	Description	品名	Amt. Req.
1	37372	Needle Bar for DCZ-222, -223	針棒(DCZ-222, -223)	1
2	37373	Needle Holder for DCZ-222, 223	針止メ(DCZ-222, -223)	1
3	3637	Screws for Needle	針止ネジ	2
4	32558	Thread Lead Bar	糸道棒	1
5	32968	Needle Thread Tension Disc Eyelet for DCZ-222,-223	調子台糸道	1
6	6543	Tension Post for DCZ-222, -223	糸調子棒	1
7	340	Nut for 6543	糸調子棒止ナット	1
8	286	Felt for Tension Disc	フェルト	1
9	01111	Tension Discs for DCZ-202	糸調子皿(DCZ-202)	6
		Tension Discs for DCZ-222, -223	糸調子皿(DCZ-222, -223)	8
10	37635	Thread Tension Spring Retainer for DCZ-202	渦巻キバネキャップ(下)(DCZ-202)	3
		Thread Tension Spring Retainer for DCZ-222, -223	渦巻キバネキャップ(下)(DCZ-222, -223)	4
11	32971	Needle Thread Tension Spring for DCZ-202	渦巻キバネ(大)(DCZ-202)	1
		Needle Thread Tension Spring for DCZ-222, -223	渦巻キバネ(大)(DCZ-222, -223)	2
12	30254	Tension Spring Bushing for DCZ-202	糸調子ナット廻り止(組)(DCZ-202)	3
		Tension Spring Bushing for DCZ-222, 223	糸調子ナット廻り止(組)(DCZ-222, -223)	4
13	32965	Thread Tension Spring Cap for DCZ-202	渦巻キバネキャップ(上)(DCZ-202)	3
		Thread Tension Spring Cap for DCZ-222, -223	渦巻キバネキャップ(上)(DCZ-222, -223)	4
14	32542	Presser Foot Complete Set for DCZ-202 #2	押工(組)(DCZ-202, #5)	1
15	32579	Presser Foot Complete Set for DCZ-222, -223 #2	押工(組)(DCZ-222, -223, #2)	1
16	32546	Presser Foot Holder	押工(上)	1
17	32494	Presser Foot for DCZ-202 #5, DCZ-222, -223 #2	押工(下)	1
18	32493	Presser Foot Chip Guard for DCZ-202 #5, -222, -223 #2	押工チップ	1
19	1230	Screw for 32493	押工チップ止ネジ	1
20	32495	Presser Foot Stitch Tongue for DCZ-202 #5	爪 #5	1
21	30619	Presser Foot Hinge Spring	押工ヒンジバネ	1
22	5036	Screw for 32495	爪止ネジ	1
23	32746	Presser Foot Chain Shield	空糸押工	1
24	1228	Screw for 32746	空糸押工止ネジ	1
25	32551	Presser Foot Stitch Tongue for DCZ-222, -223 #2	爪 #2	1
26	32570	Throat Plate for DCZ-202 #5	針板 #5	1
27	32571	Throat Plate for DCZ-222, -223 #2	針板 #2	1
28	33819	Differential Feed Dog (Large Teeth) for DCZ-202 #15, DCZ-222, -223 #2	前送り(荒歯)	1
29	33818	Main Feed Dog (Large Teeth)	後送り(荒歯)	1
30	32557	Chaining Feed Dog (Large Teeth)	小送り(荒歯)	1
31	32541	Lower Loper for DCZ-202, -222	下ルーバー(DCZ-202, -222)	1
32	32416	Lower Loper for DCZ-223	下ルーバー(DCZ-223)	1
33	32539	Upper Loper for DCZ-202, -222	上ルーバー(DCZ-202, -222)	1
34	32540	Upper Loper for DCZ-223	上ルーバー(DCZ-223)	1

Ref. No.	Parts No.	Description	品名	Amt. Req.
	33347	Presser Foot Complete Set #2 #3 for DCZ-245	押工(組) #2、#3 (DCZ-245)	1
1-1	33346	Presser Foot Complete Set #1 for DCZ-245	押工(組) #1 (DCZ-245)	1
2	33358	Presser Foot Complete Set for DCZ-246	押工(組) (DCZ-246)	1
3	32869	Presser Foot Complete Set for Attaching Tape #1	押工(組) #1 (DCZ-203M)	1
3-1	32874	Presser Foot Complete Set for Attaching Tape #2, #3	押工(組) #2、#3 (DCZ-203M)	1
4	32741	Presser Foot Holder	押工(上)	1
5	33348	Presser Foot Stay	押工固定片	1
6	4404	Screws for 33348, 33718	止ネジ	2
7	33342	Presser Foot	押工(下)	1
8	32743	Presser Foot Stitch Tongue #2, #3 for DCZ-245	爪 #2、#3 (DCZ-245)	1
	32744	Presser Foot Stitch Tongue #1 for DCZ-245	爪 #1 (DCZ-245)	1
9	30619	Presser Foot Hinge Spring	押工ヒンジバネ	1
10	5036	Screw for 32743, 32744, 33425	押工ヒンジバネ止ネジ	1
11	34535	Presser Foot Chain Shield	空糸押工	1
12	1230	Screws for 34535	空糸押工止ネジ	3
13	32749	Presser Foot Stitch Tongue for DCZ-246	爪 (DCZ-246)	1
14	33344	Main Feed Dog for DCZ-245, -246	後送り (DCZ-245, -246)	1
15	33343	Differential Feed Dog for DCZ-245, -246	前送り (DCZ-245, -246)	1
16	33356	Presser Plate Assembly for DCZ-245, -246	ギャザ取り装置(組)	1
17	7405	Screws for 33356, 33400	止ネジ	2
18	33355	Presser Plate for DCZ-245, -246	ギャザ取り押工 (DCZ-245, -246)	1
19	33400	Front Cover Latch Spring for DCZ-245, -246	前開キカバーバネ (DCZ-245, -246)	1
20	32875	Presser Foot for Attaching Tape	押工下(テープ入レ)	1
21	32876	Presser Foot Tape Guide for Upper	テープガイド(上)	1
22	32707	Presser Foot Tape Guide for Lower	テープガイド(下)	1
23	32710	Presser Foot Chip Guard	押工チップ	1
24	33723	Throat Plate #1 for DCZ-203M	針板 #1 (DCZ-203M)	1
24-1	33727	Throat Plate #2 for DCZ-203M	針板 #2 (DCZ-203M)	1
24-2	33728	Throat Plate #3 for DCZ-203M	針板 #3 (DCZ-203M)	1
25	33700	Solenoid	ソレノイド	1
26	6661	Screws for 33700	ソレノイド止ネジ	4
27	33701	Solenoid Holder	ソレノイド取付台	1
28	5550	Screws for 33701	ソレノイド取付台止ネジ	2
29	538	Washers for 33701	ソレノイド取付台座金	2
30	92226	Cord Supporter	コード支工	1
31	33718	Presser Foot Release Lever Stopper	手揚げストッパー	1
32	33726	Tape Trimmer Complete Set	メス装置(組)	1
33	33706	Upper Knife	上メス	1
34	33716	Lower Knife	下メス	1
35	33702	Solenoid Connecting Rod	ソレノイド連結桿	1
36	33703	Solenoid Connecting Rod Pin	連結桿ピン	1
37	33024	Retaining Ring for 33703	連結桿ピンストップリング	1
38	33704	Solenoid Spring	ソレノイドバネ	1
39	33705	Solenoid Spring Hook	バネ掛け	1
40	1175	Screw for 33705	バネ掛け止ネジ	1
41	33720	Cloth Plate (Upper)	大カバー	1
42	35715	Knee Switch Complete Set	膝スイッチ(組)	1
43	1170	Screws for 11681	膝スイッチ止ネジ	2
44	35705	Plate for Switch Box	スイッチケース裏蓋	1
45	92232	Holder for 11681	スイッチ取付板	1
46	—	Wood Screws for 92232	木ネジ	2
47	33722	Control Box Complete Set	整流器(組)	1
48	—	Wood Screws for 33722	木ネジ	4
49	33719	Presser Foot Release Lever	手揚げ	1
50	33732	Tape Guide Complete Set	テープガイド(組)	1
51	33463	Cloth Plate Hinge	横カバーヒンジ	1

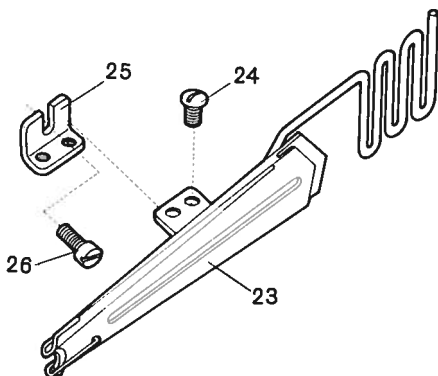
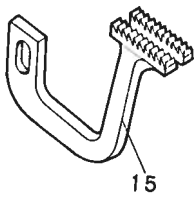
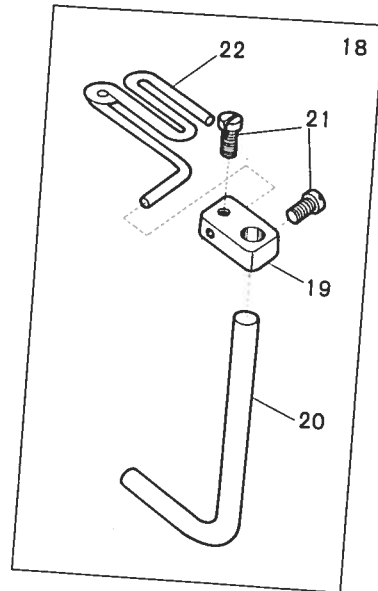
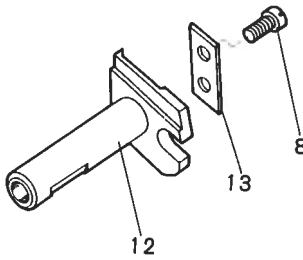
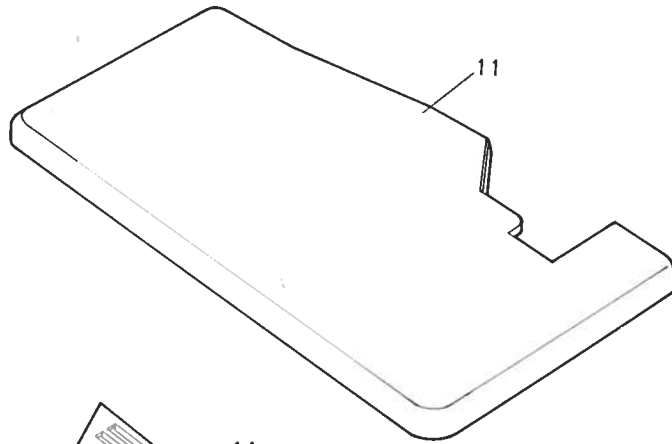
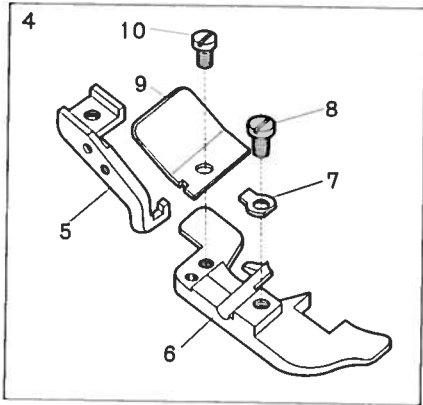
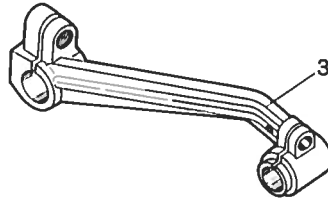
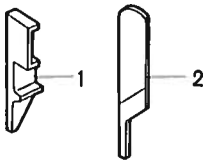

<u>Ref. No.</u>	<u>Parts No.</u>	<u>Description</u>	<u>品 名</u>	<u>Amt. Req.</u>
1	32556	Upper Knife Clamp	上メス押シ	1
2	33429	Upper Knife	上メス	1
3	33140	Upper Knife Driving Arm	上メス台	1
4	33420	Presser Foot Complete Set	押工(組)	1
5	33434	Presser Foot Holder	押工(上)	1
6	33421	Presser Foot	押工(下)	1
7	30619	Presser Foot Hinge Spring	押工ヒンジバネ	1
8	5036	Screws for 30619, 33425	止ネジ	3
9	32746	Presser Foot Chain Shield	空糸押工	1
10	1230	Screw for 34535	空糸押工止ネジ	1
11	33428	Cloth Plate (Upper)	大カバー	1
12	33424	Lower Knife Holder	下メス台	1
13	33425	Lower Knife Clamp	下メス押シ	1
14	33422	Throat Plate	針板	1
15	33820	Differential Feed Dog	前送り	1
16	33814	Main Feed Dog	後送り	1
17	33328	Chaining Feed Dog	小送り	1
18	33430	Strip Guide Assembly	テープガイド(組)	1
19	33433	Strip Guide Bracket	テープガイド取付片	1
20	33431	Strip Guide Holder Shaft	テープガイド取付台	1
21	7616	Screws for 33433	テープガイド取付片止ネジ	2
22	33432	Strip Guide	テープガイド	1
23	33427	Folder	定規(組)	1
24	1330	Screws for 33427	定規止ネジ	2
25	33426	Folder Bracket	定規取付台	1
26	1175	Screw for 33426	定規取付台止ネジ	1

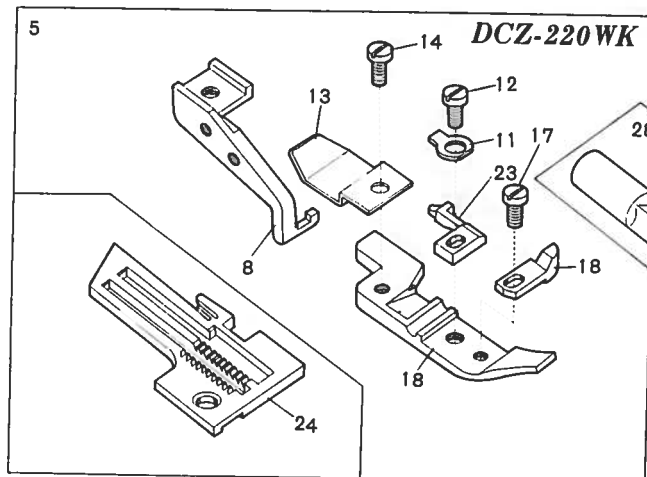
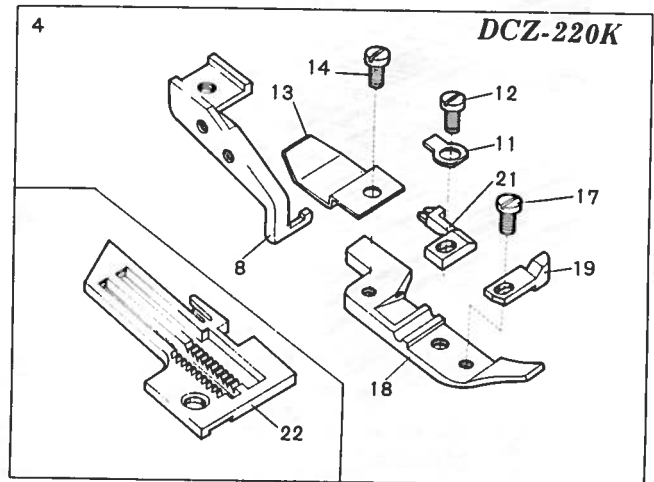
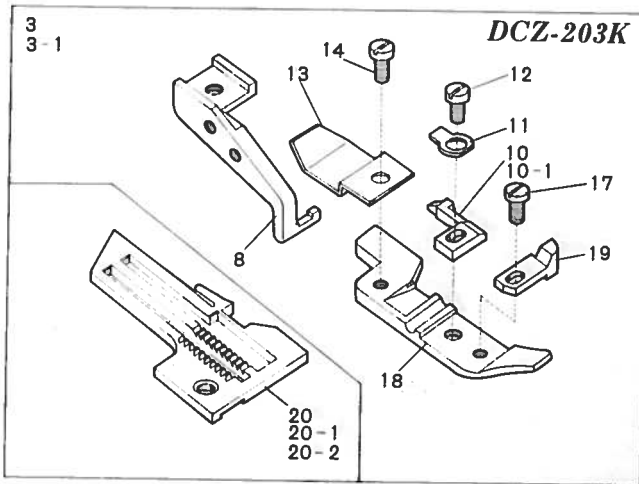
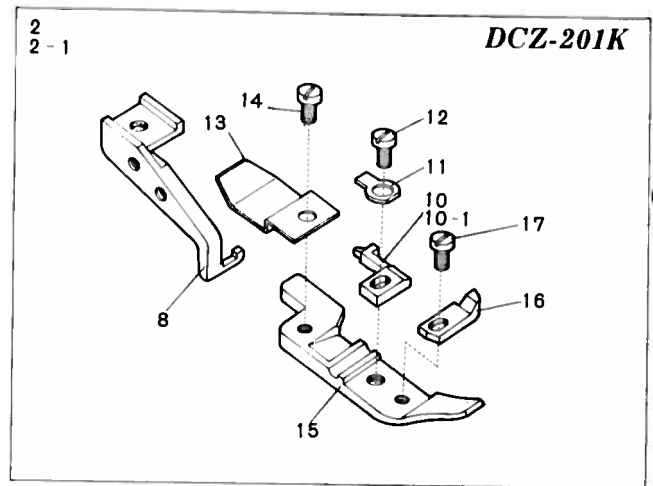
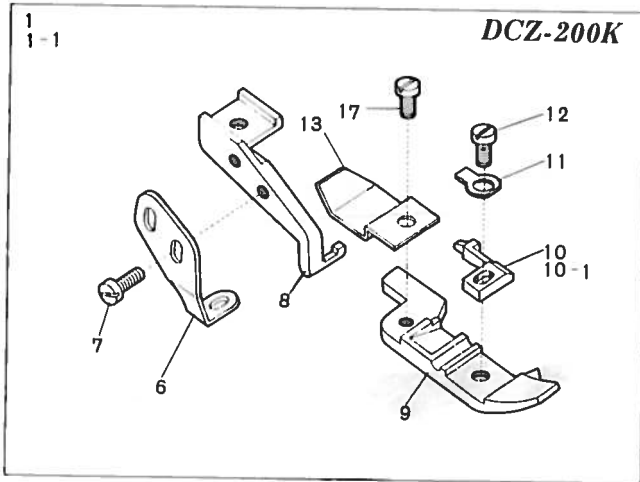

"K" DEVICE

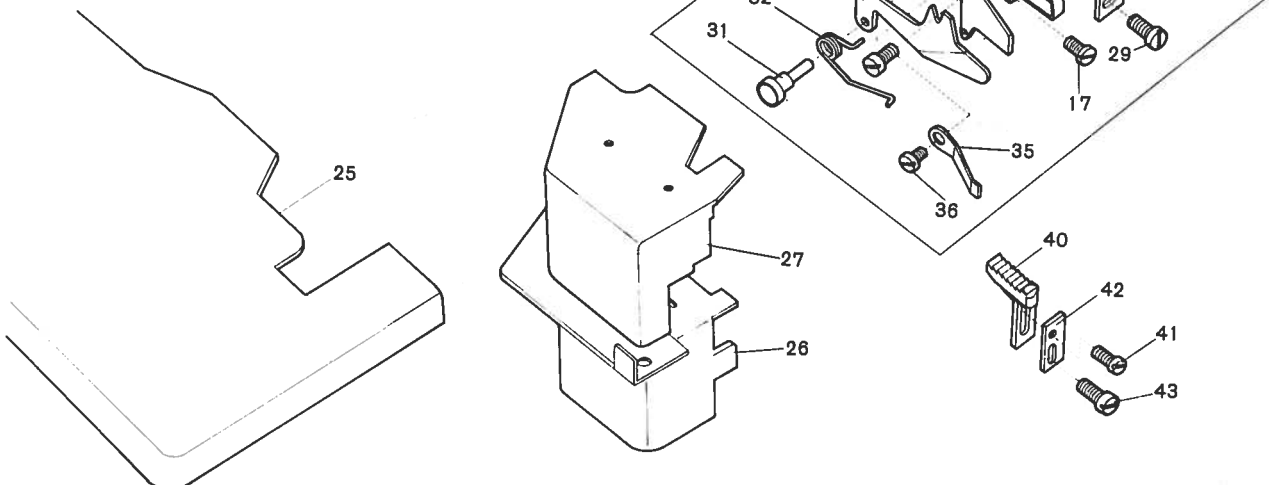

<u>Ref. No.</u>	<u>Parts No.</u>	<u>Description</u>	<u>品 名</u>	<u>Amt. Req.</u>
1	33479	Presser Foot Complete Set #1 for DCZ-200K	押工(組) #1 (DCZ-200K)	1
1-1	33480	Presser Foot Complete Set #2, #3 for DCZ-200K	押工(組) #2, #3 (DCZ-200K)	1
2	33481	Presser Foot Complete Set #1 for DCZ-201K	押工(組) #1 (DCZ-201K)	1
2-1	33482	Presser Foot Complete Set #2, #3 for DCZ-201K	押工(組) #2, #3 (DCZ-201K)	1
3	33483	Presser Foot Complete Set #1 for DCZ-203K	押工(組) #1 (DCZ-203K)	1
3-1	33484	Presser Foot Complete Set #2, #3 for DCZ-203K	押工(組) #2, #3 (DCZ-203K)	1
4	33485	Presser Foot Complete Set for DCZ-220K	押工(組) (DCZ-220K)	1
5	33499	Presser Foot Complete Set for DCZ-220WK	押工(組) (DCZ-220WK)	1
6	32737	Presser Foot Stay	押工固定片	1
7	4404	Screws for 32737	押工固定片止ネジ	2
8	32741	Presser Foot Holder	押工(上)	1
9	33468	Presser Foot for DCZ-200K	押工(下)	1
10	32744	Presser Foot Stitch Tongue #1	爪 #1	1
10-1	32743	Presser Foot Stitch Tongue #2, #3	爪 #2, #3	1
11	30619	Presser Foot Hinge Spring	押工ヒンジバネ	1
12	5036	Screw for Stitch Tongue	爪止ネジ	1
13	33471	Presser Foot Chain Shield	空糸押工	1
14	1228	Screw for 33471	空糸押工止ネジ	1
15	33469	Presser Foot for DCZ-201K	押工(下)	1
16	32745	Presser Foot Chip Guard for DCZ-201K	押工チップ	1
17	1230	Screws for 32745	押工チップ止ネジ	2
18	33470	Presser Foot for DCZ-203K, -220K	押工(下)	1
19	32710	Presser Foot Chip Guard for DCZ-203K, -220K, -220WK	押工チップ	1
20	33465	Throat Plate #1	針板 #1	1
20-1	33466	Throat Plate #2	針板 #2	1
20-2	33467	Throat Plate #3	針板 #3	1
21	32749	Presser Foot Stitch Tongue for DCZ-220K	爪	1
22	33491	Throat Plate for DCZ-220K	針板	1
23	32761	Presser Foot Stitch Tongue for DCZ-220WK	爪	1
24	33497	Throat Plate for DCZ-220WK	針板	1
25	33462	Cloth Plate	大カバー	1
26	33910	Feed Mechanism Oil Shield	送りリンクカバー(小)	1
27	33464	Feed Mechanism Cover	送りリンクカバー	1
28	33902	Suction Pipe Complete Set	吸込管(組)	1
29	4353	Screws for 33902, 33452	吸込管(組)止ネジ	4
30	33903	Suction Pipe	吸込管	1
31	33459	Trimming Knife Holder Pin	刃支持ピン	1
32	33458	Trimming Knife Spring	下刃バネ	1
33	33456	Trimming Knife (Upper)	上刃	1
34	33907	Trimming Knife (Lower)	下刃	1
35	33911	Trimming Knife Reinforced Spring	下刃圧着バネ	1
36	4237	Screw for 33911	下刃圧着バネ止ネジ	1
37	33452	Suction Pipe Holder (Front)	吸込管支工(前)	1
38	7006	Screws for 33452	吸込管支工(前)止ネジ	2
39	33463	Cloth Plate Hinge	横カバーヒンジ	1
40	33461	Auxiliary Feed Dog	小送り	1
41	4315	Screw for 33461	小送り止ネジ	1
42	33460	Trimming Knife Spring	下刃ガイド	1
43	7609	Screw for 33460	下刃ガイド止ネジ	1

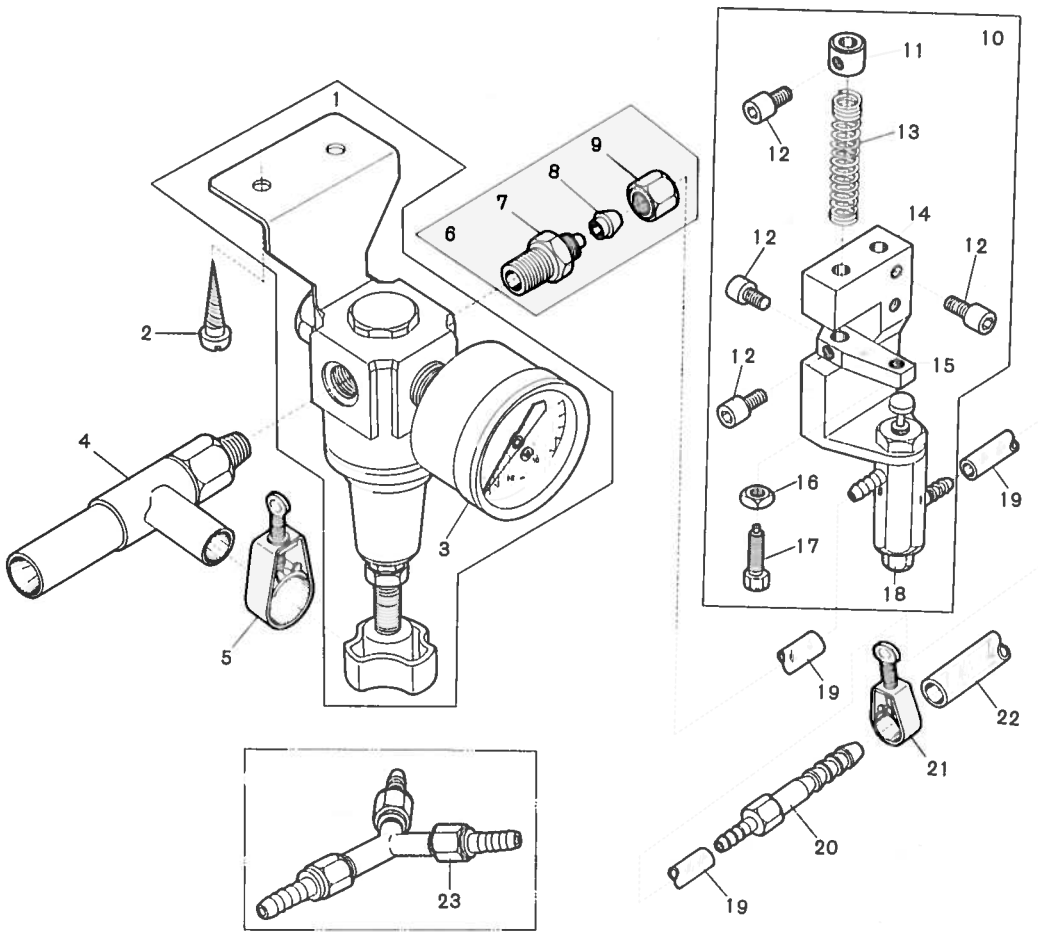

'C' DEVICE

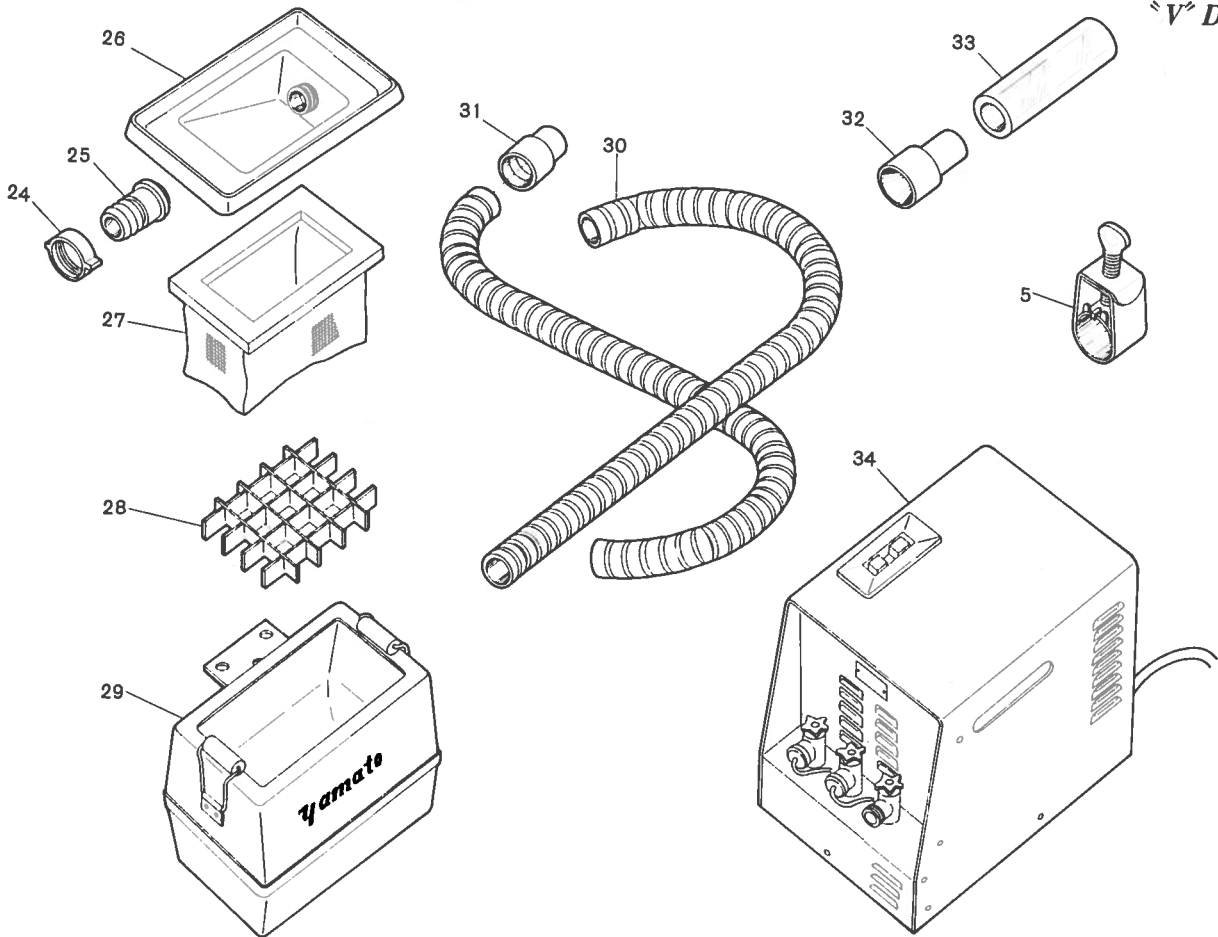

'V' DEVICE

Ref. No.	Parts No.	Description	品 名	Amt. Req.
1	33925	Regulator Complete Set	レギュレーター(組)	1
2	6905	Screws for 33925	レギュレーター取付ネジ	2
3	33928	Pressure Gauge	プレッシャーゲージ	1
4	33930	Venturi Tube Complete Set	ベンチュリー管(組)	1
5	33940	Hose Band 3/8"	3/8"ホースバンド	1
6	33931	Mouth-Piece Charge 1/8" Complete Set	1/8"ストレートジョイント(組)	1
7	33949	Mouth-Piece Charge 1/8"	1/8"ストレートジョイント	1
8	33951	Pipe Holder	ナイロンホルダー	1
9	33950	Nut for Straight Joint	ナット	1
10	33953	Air Valve Complete Set	エヤバルブ(組)	1
11	33938	Collar for Air Valve Spring	エヤバルブ補助バネカラー	1
12	5040	Screws for 33938, 33935, 33936	止ネジ	6
13	33937	Return Spring for Air Valve Stopper	エヤバルブ補助バネ	1
14	33936	Holder for Air Valve	エヤバルブ取付台	1
15	33935	Air Valve Stopper	エヤバルブストッパー	1
16	334	Nut for 33935	ナット	1
17	5505	Screw for 33935	エヤバルブストッパー調節ネジ	1
18	33934	Air Valve	エヤバルブ	1
19	33941	Nylon Hose	ナイロンホース	1
20	33932	Joint for Used a single Head	ジョイント(ミシンが1台の時のみ使用)	1
21	33939	Hose Bands 1/4"	1/4"ホースバンド	3
22	33942	Nylon Hose	ナイロンホース	1
23	33933	Three Pronged Joint for Used Plural Heads	三又ジョイント(ミシンが2台以上の時使用)	1
24	33505	Hose Pipe Bases (Upper)	ホース口金(上)	2
25	33506	Hose Pipe Bases (Lower)	ホース口金(下)	2
26	33507	Trimmed Thread Collector Cap	コレクター蓋	1
27	33508	Trimmed Thread Collector Net	集塵袋	1
28	33509	Trimmed Thread Collector Net Holder	集塵袋支工	1
29	33495	Trimmed Thread Collector Complete Set	コレクター本体	1
30	33504	Hose	ホース	2
31	33503	Hose Joints	ホースジョイント	3
32	33926	Middle Joint for Hose Pipe	ジョイント	1
33	33952	Nylon Hose	ナイロンホース	1
34	33486	YV-100 (Suction Pump)	吸引ポンプ(YV-100)	1

Note		注記	
Please note that the following devices have been explained.		下記装置の説明を参照下さい。	
“K” Device	Automatic Chain-thread Cutter	“K” 装置	自動カラ環切り装置
“C” Device	With this unit the thread chain trimmed with “K” chain-thread Cutter is blown into a Suction Pipe automatically by means of Air Compressor system. (A Compressor is available at extra charge.)	“C” 装置	この装置は自動カラ環切り装置で切断されたカラ環をエア・コンプレッサーによって自動的に吸込管に吸込む装置です。 (コンプレッサーは必要に応じて特別注文で御利用下さい。)
“V” Device	With this unit the thread chain trimmed with “K” chain-thread Cutter is blown into a Pipe by means of Vacuum Pump system. (A Vacuum Pump is available at extra charge on request.)	“V” 装置	この装置は自動カラ環切り装置で切断されたカラ環を吸引ポンプによって自動的に吸込管に吸込む装置です。 (吸引ポンプは必要に応じて特別注文で御利用下さい。)
“KC” Device	This is complete set consisting of “K” chain-thread Cutter and “C” Device of Air Compressor system.	“KC” 装置	この装置は“K”装置と“C”装置を併用しています。
“KV” Device	This is complete set consisting of “K” chain-thread Cutter and “V” Device of Vacuum Pump system.	“KV” 装置	この装置は“K”装置と“V”装置を併用しています。

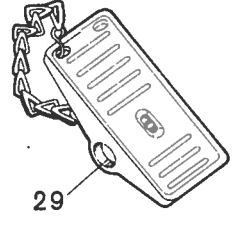
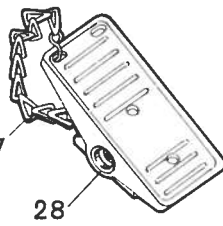
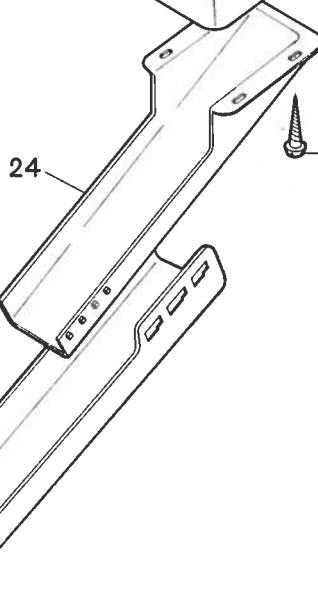
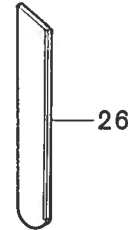
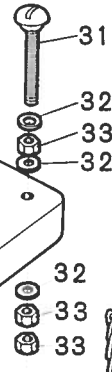
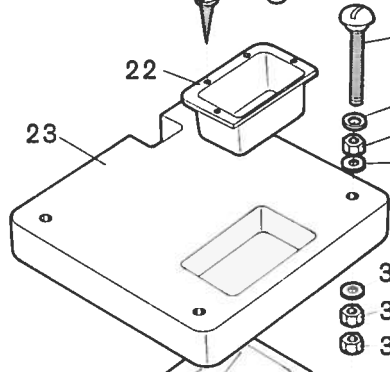
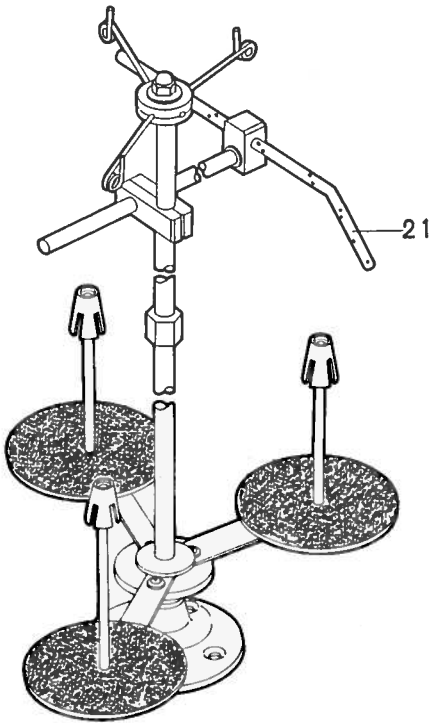
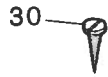
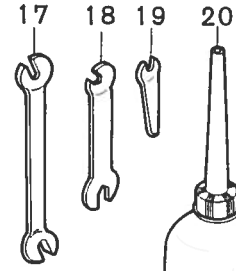
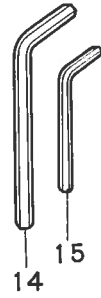
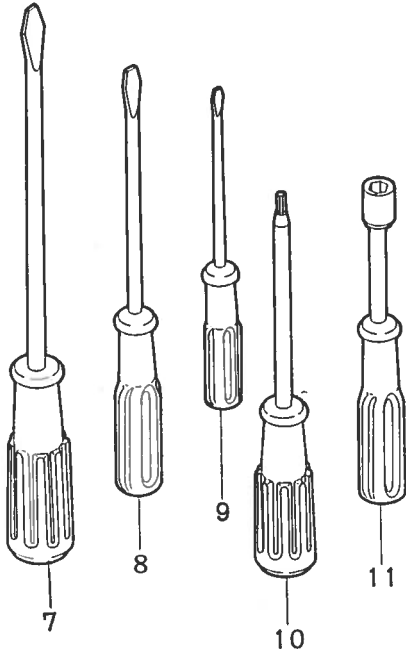
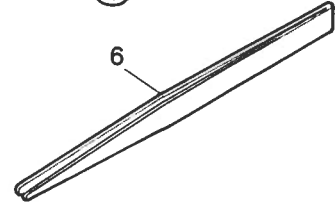
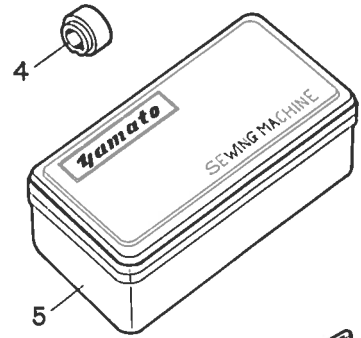
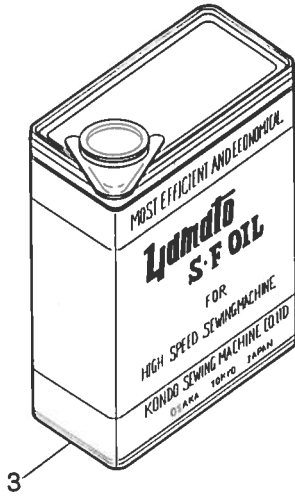
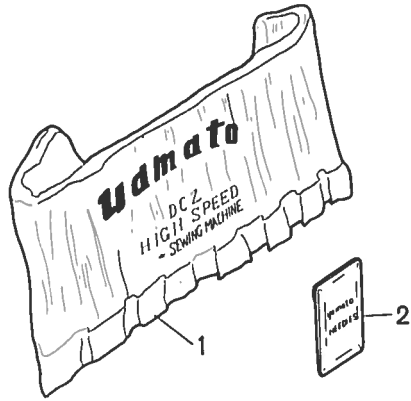

Ref. No.	Parts No.	Description	品名	Amt. Req.	Exp't. 国内
1	37939	Machine Cover	ビニールカバー	1	1
2		Needles DC×1	針(DC×1)	10	10
3		Oil	オイル	1	1
4		Feed Driving Eccentric	送り前後エキセン	3	2
5	37913	Attachment Box	付属品箱	1	1
6	37909	Thread Tweezers	ピンセット	1	1
7	37901	Screw Driver (Large)	ドライバー(大)	1	1
8	37902	Screw Driver (Medium)	ドライバー(中)	1	1
9	37903	Screw Driver (Small)	ドライバー(小)	1	1
10	37923	Hexagon Screw Driver (1.98)	六角レンチ付ドライバー(1.98)	1	1
11	37946	Socket Wrench (9.52)	ソケットレンチ(9.52)	1	1
12	37947	Feed Driving Eccentric Extractor	送りエキセン抜き	1	1
13	37919	Hexagon Screw Driver (Two Needle Only) (1.56)	六角レンチ付ドライバー(1.56)	1	1
14	37922	Hexagon Wrench Key (Large) (4.76)	キーレンチ(4.76)	1	1
15	37916	Hexagon Wrench key (Small) (3.18)	キーレンチ(3.18)	1	1
16	37943	Funnel	ジョウゴ	1	1
17	37945	Wrench (Large) (7.14×7.94)	両口スパナ(7.14×7.94)	1	1
18	37915	Wrench (Medium) (7.14×7.14)	両口スパナ(7.14×7.14)	1	1
19	37944	Wrench (Small) (4.9)	片口スパナ(4.9)	1	1
20	37932	Oiler	油差シ	1	1
21	32550	Thread Stand 3 Spool Thpe Complete Set	三本糸用糸立(組)	1	
22	30080	Window of Chute	トユ受け	1	1
23	30083	Supporting Board	受板	1	1
24	30081	Chute (Upper)	トユ(上)	1	1
25	30082	Chute (Lower)	トユ(下)	1	1
26	30421	Lower Knife	下メス	1	1
27	37912	Chain	クサリ	1	1
28	37907	Pedal Complete Set	ペダル(組)	1	
29	37911	Pedal Complete Set	ペダル(組)		1
30		Wood Screws	木ネジ	4	4
31		Bolts for Supporting Board	受板吊りボルト	4	4
32		Washers	ワッシャ	4	4
33		Nuts	ナット	12	12
34		Wood Screws	木ネジ	4	4

INDEX

Parts. No.	Page No.	Ref. No.	Parts. No.	Page No.	Ref. No.	Parts. No.	Page No.	Ref. No.	Parts. No.	Page No.	Ref. No.
10	3	27	1228	3	25	4358	6	25	5550	14	28
20	8	19	1228	10	16	4358	9	42	6000	7	30
62	5	8	1228	11	25	4358	10	38	6004	3	28
282	5	2	1228	13	24	4358	12	6	6040	1	17
282	6	22	1228	16	14	4402	4	17	6262	3	36
286	2	10	1230	7	8	4404	5	43	6330	9	37
286	3	3	1230	10	11	4404	7	10	6401	7	47
286	11	4	1230	11	20	4404	14	6	6542	3	2
286	13	8	1230	13	19	4404	16	7	6543	11	2
304	4	34	1230	14	12	4435	2	5	6543	13	6
304	6	27	1230	15	10	4437	5	26	6544	2	8
316	3	45	1230	16	17	4438	3	10	6661	14	26
331	9	49	1326	1	26	4440	1	23	6662	5	45
334	2	30	1326	3	12	4440	2	25	6861	9	28
334	7	41	1326	6	44	4440	2	36	6905	17	2
334	17	16	1330	1	24	4440	5	56	6910	3	37
335	7	18	1330	3	42	4440	8	21	7006	3	14
340	11	3	1330	15	24	4441	4	14	7006	16	38
340	13	7	1333	2	22	4591	5	48	7302	1	9
419	9	13	1435	4	39	4635	7	45	7311	5	38
419	9	29	1448	4	43	5000	8	23	7405	14	17
451	8	18	1457	4	29	5004	6	29	7605	1	11
509	9	23	1459	2	38	5036	7	4	7605	5	53
520	6	18	1459	7	32	5036	10	14	7609	4	4
525	2	18	1459	9	36	5036	11	23	7609	8	27
526	4	36	2022	7	26	5036	13	22	7609	16	43
527	4	45	2133	4	26	5036	14	10	7616	5	30
532	3	41	3311	5	10	5036	15	8	7616	15	21
538	7	13	3311	6	23	5036	16	12	7650	4	6
538	14	29	3404	6	9	5040	17	12	7650	6	30
550	2	24	3434	2	42	5062	3	20	7668	9	46
550	9	32	3434	5	33	5071	5	20	7678	2	32
563	3	34	3591	4	16	5071	6	2	9127	7	40
567	3	19	3595	4	22	5074	5	50	9142	6	33
567	9	45	3632	8	2	5075	2	19	9150	1	2
690	7	36	3635	5	18	5075	3	48	9150	2	2
698	2	34	3635	6	7	5089	1	33	9150	2	17
722	8	8	3635	8	3	5089	2	28	9150	3	23
723	5	31	3636	4	37	5095	1	18	9200	8	5
726	1	14	3637	11	12	5131	1	28	9203	4	18
865	1	35	3637	13	3	5133	9	48	9209	4	20
866	1	35-1	3638	6	46	5345	6	16	9503	9	39
867	1	35-2	3654	4	24	5401	5	41	9506	6	5
868	1	35-3	4237	16	36	5500	6	19	9517	5	15
869	1	35-4	4313	5	5	5505	7	42	9604	5	12
926	9	38	4315	16	41	5505	17	17	9604	6	41
1092	3	17	4351	3	30	5507	6	36	9604	9	18
1156	2	33	4351	9	43	5508	5	28	9604	9	18
1170	14	43	4353	1	9	5509	7	14	9730	8	25
1174	5	27	4353	8	29	5517	10	46	9851	3	46
1175	14	40	4353	9	33	5518	10	44	9853	9	2
1175	15	26	4353	10	42	5520	5	16	9909	9	19
1186	5	6	4353	16	29	5541	7	17	01111	13	9
1186	7	22	4357	7	19	5550	6	12	01111	11	5
1222	1	25	4358	2	40	5550	7	28	01111	3	4

INDEX

Parts. No.	Page No.	Ref. No.	Parts. No.	Page No.	Ref. No.	Parts. No.	Page No.	Ref. No.	Parts. No.	Page No.	Ref. No.
01111	2	9	32477	1	32	32604	5	46	32706	7	9
11681	14	42	32479	9	16	32605	2	27	32707	14	22
30080	18	22	32480	9	14	32606	1	29	32708	10	17
30081	18	24	32483	9	12	32607	1	30	32708	11	18
30082	18	25	32484	2	35	32608	1	31	32710	10	18
30083	18	23	32488	12	25	32609	2	39	32710	11	19
30126	1	16	32490	12	24	32610	1	22	32710	14	23
30228	6	40	32493	13	18	32611	1	27	32710	16	19
30254	2	13	32494	13	17	32612	2	41	32711	7	37
30254	3	7	32495	10	12-2	32613	2	1	32713	7	35
30254	11	8	32495	13	20	32614	2	15	32714	7	33
30254	13	12	32498	12	28	32615	2	16	32715	7	34
30291	4	40	32519	5	34	32617	1	1	32716	7	39
30421	5	51	32530	12	1	32618	1	3	32717	7	29
30421	18	26	32531	12	13	32619	1	4	32718	7	27
30619	7	3	32532	12	2	32620	1	5	32719	7	31
30619	10	13	32533	12	3	32622	1	7	32720	7	25
30619	11	22	32534	12	8	32623	1	8	32721	7	24
30619	13	21	32539	13	33	32624	2	23	32722	7	20
30619	14	9	32540	13	34	32625	3	26	32723	7	21
30619	15	7	32541	13	31	32626	3	29	32724	7	15
30619	16	11	32542	13	14	32627	3	11	32725	7	12
30711	9	35	32543	12	11	32628	1	19	32726	7	46
30745	9	27	32544	10	22	32629	1	20	32727	7	43
30748	9	26	32544	12	26	32640	1	21	32728	7	16
32336	10	34	32545	12	26-1	32644	5	14	32729	7	30
32340	11	30	32546	12	16	32645	5	9	32731	10	6
32341	11	33	32550	18	21	32646	5	11	32732	10	28
32342	11	27	32551	13	25	32647	4	31	32734	7	11-1
32343	11	16	32552	12	10	32648	4	28	32735	7	11
32347	6	26	32554	12	12	32649	9	5	32736	7	1
32348	6	30	32556	12	9	32650	4	30	32737	16	6
32358	3	43	32556	15	1	32651	5	4	32738	10	3
32359	11	38	32557	13	30	32652	4	35	32739	10	3-1
32365	2	26	32558	13	4	32653	4	33	32740	10	9
32373	12	18	32570	13	26	32654	5	54	32741	7	5
32374	12	16	32571	13	27	32655	5	42	32741	10	8
32375	3	33	32572	12	4	32656	11	38-1	32741	11	17
32376	9	22	32575	12	5	32658	11	39	32741	14	4
32377	3	35	32576	12	27	32660	3	38	32741	16	8
32381	8	20	32577	12	21	32662	5	17	32743	7	2-1
32394	10	4-2	32579	13	15	32663	3	9	32743	10	12-1
32415	11	34	32580	12	19	32666	5	40	32743	14	8
32416	13	32	32582	12	20	32667	5	40-1	32743	16	10-1
32417	9	30	32583	12	22	32668	10	24	32744	7	2
32418	11	37	32584	12	23	32669	10	29	32744	10	12
32420	7	44	32585	12	7	32670	5	19	32744	14	8-1
32421	3	47	32586	2	29	32671	10	19	32744	16	10
32423	3	13	32597	2	3	32672	10	19-1	32745	10	10
32424	3	18	32599	2	31	32673	10	19-2	32745	16	16
32425	3	15	32600	1	34	32677	11	28	32746	13	23
32426	3	16	32601	5	44	32678	11	29	32746	15	9
32427	11	13	32602	1	10	32682	5	40-2	32747	10	4
32475	3	24	32603	1	12	32684	4	32	32748	10	4-1
32476	9	17	32604	1	15	32685	9	1	32749	11	21

INDEX

Parts. No.	Page No.	Ref. No.	Parts. No.	Page No.	Ref. No.	Parts. No.	Page No.	Ref. No.	Parts. No.	Page No.	Ref. No.
32749	14	13	32856	8	11	32962	3	1	33461	16	40
32749	16	21	32857	8	6	32962	2	7	33462	16	20
32750	11	14	32858	8	4	32963	2	37	33463	14	51
32754	10	23	32864	8	7	32965	2	14	33463	16	39
32755	10	5	32866	8	12	32965	3	8	33464	16	27
32757	10	4-3	32867	8	10	32965	11	9	33465	16	20
32759	10	12-3	32868	4	44	32965	13	13	33466	16	20-1
32760	11	15	32869	14	3	32968	11	1	33467	16	20-2
32761	11	26	32871	10	1	32968	13	5	33468	16	9
32761	16	23	32873	10	2	32970	2	4	33469	16	15
32772	4	15	32873	10	27	32971	2	12	33470	16	18
32773	4	3	32874	14	3-1	32971	11	7	33471	16	13
32774	4	1	32875	14	20	32971	13	11	33472	16	26
32775	4	10	32876	14	21	32973	3	32	33479	16	1
32777	4	11	32883	8	24	32974	2	6	33480	16	1-1
32778	4	9	32892	10	25	32975	3	31	33481	16	2
32779	4	8	32893	10	26	32976	3	21	33482	16	2-1
32780	4	2	32898	9	10	32977	3	22	33483	16	3
32781	4	19	32899	5	55	33013	6	15	33484	16	3-
32782	4	21	32900	5	39	33024	7	23	33485	16	4
32783	6	1	32902	5	36	33024	14	37	33486	17	34
32784	6	4	32903	5	35	33140	15	3	33491	16	22
32785	6	3	32904	4	23	33328	15	17	33495	17	29
32786	6	8	32905	4	25	33342	14	7	33497	16	24
32787	6	6	32906	4	27	33343	14	15	33499	16	5
32788	6	39	32909	5	32	33344	14	14	33503	17	31
32789	6	42	32910	5	25	33346	14	1-1	33504	17	30
32790	6	45	32911	5	23	33347	14	1	33505	17	24
32792	6	11	32912	5	29	33348	14	5	33506	17	25
32793	4	41	32913	5	22	33355	14	18	33507	17	20
32794	4	46	32914	5	24	33356	14	16	33508	17	27
32795	4	47	32916	5	47	33358	14	2	33509	17	28
32799	6	21	32917	5	52	33400	14	19	33700	14	25
32800	6	20	32919	5	49	33420	15	4	33701	14	27
32802	4	42	32920	5	37	33421	15	6	33702	14	35
32803	6	35	32921	5	13	33422	15	14	33703	14	36
32806	9	31	32924	2	20	33424	15	12	33704	14	38
32807	6	34	32925	4	7	33425	15	13	33705	14	39
32810	11	35	32929	9	34	33426	15	25	33706	14	33
32811	11	36	32930	2	21	22427	15	23	33716	14	34
32812	9	3	32931	9	8	33428	15	11	33718	14	31
32813	10	35	32933	9	9	33429	15	2	33719	14	49
32815	6	37	32934	9	7	33430	15	18	33720	14	41
32816	6	38	32935	9	40	33431	15	20	33722	14	47
32817	4	13	32937	9	41	33432	15	22	33723	14	24
32818	4	12	32938	9	24	33433	15	19	33726	14	32
32819	5	21	32944	9	47	33434	15	5	33727	14	24-
32820	4	5	32948	9	50	33447	10	7	33728	14	24-2
32848	6	13	32949	9	52	33448	10	30	33732	14	50
32849	6	14	32952	3	6	33449	10	31	33751	10	39
32850	9	21	32955	3	40	33452	16	37	33758	10	45
32851	8	17	32958	11	43	33456	16	33	33759	10	41
32852	8	15	32959	6	43	33458	16	32	33760	10	43
32853	8	14	32960	3	44	33459	16	31	33761	10	40
32854	8	9	32960	11	42	33460	16	42	33762	10	47

INDEX

19

<u>Parts. No.</u>	<u>Page No.</u>	<u>Ref. No.</u>	<u>Parts. No.</u>	<u>Page No.</u>	<u>Ref. No.</u>	<u>Parts. No.</u>	<u>Page No.</u>	<u>Ref. No.</u>	<u>Parts. No.</u>	<u>Page No.</u>	<u>Ref. No.</u>
33810	8	28	34518	4	38	92232	14	45			
33811	8	26	34535	7	6						
33812	8	28-1	34535	10	15						
33813	10	32	34535	11	24						
33813	11	31	34535	14	11						
33814	10	33	34536	7	7						
33814	11	32	34581	11	49						
33814	15	16	34584	11	48						
33815	10	21	34587	11	40						
33816	10	32-1	34587	12	15						
33816	11	31-1	34605	11	46						
33817	10	32-2	34607	11	44						
33818	10	33-1	35705	14	44						
33818	13	29	35715	14	42						
33819	13	28	37122	5	7						
33820	15	15	37372	11	10						
33902	16	28	37372	13	1						
33903	16	30	37373	11	11						
33907	16	34	37373	13	2						
33911	16	35	37635	2	11						
33925	17	1	37635	3	5						
33926	17	32	37635	11	6						
33928	17	3	37635	13	10						
33930	17	4	37668	9	51						
33931	17	6	37669	9	44						
33932	17	20	37675	9	20						
33933	17	23	37697	9	15						
33934	17	18	37894	11	11-1						
33935	17	15	37901	18	7						
33936	17	14	37902	18	8						
33937	17	13	37903	18	9						
33938	17	11	37907	18	28						
33939	17	21	37909	18	6						
33940	17	5	37911	18	29						
33941	17	19	37912	18	27						
33942	17	22	37913	18	5						
33949	17	7	37915	18	18						
33950	17	9	37916	18	15						
33951	17	8	37919	18	13						
33952	17	33	37922	18	14						
33953	17	10	37923	18	10						
34010	3	39	37932	18	20						
34059	8	22	37939	18	1						
34104	6	17	37943	18	16						
34134	8	1	37944	18	19						
34224	6	24	37945	18	17						
34226	6	32	37946	18	11						
34228	11	41	37947	18	12						
34258	10	20	37948	10	36						
34514	11	45	37962	10	37						
34514	12	17	37966	7	48						
34515	11	47	80503	9	25						
34515	12	14	90320	5	1						
34516	6	28	90321	5	3						
34517	6	10	92226	14	30						

