

KONDO

INDUSTRIAL SEWING MACHINE

**ILLUSTRATED SPARE PARTS LIST
FOR
HIGH SPEED
OVERLOCK MACHINE**

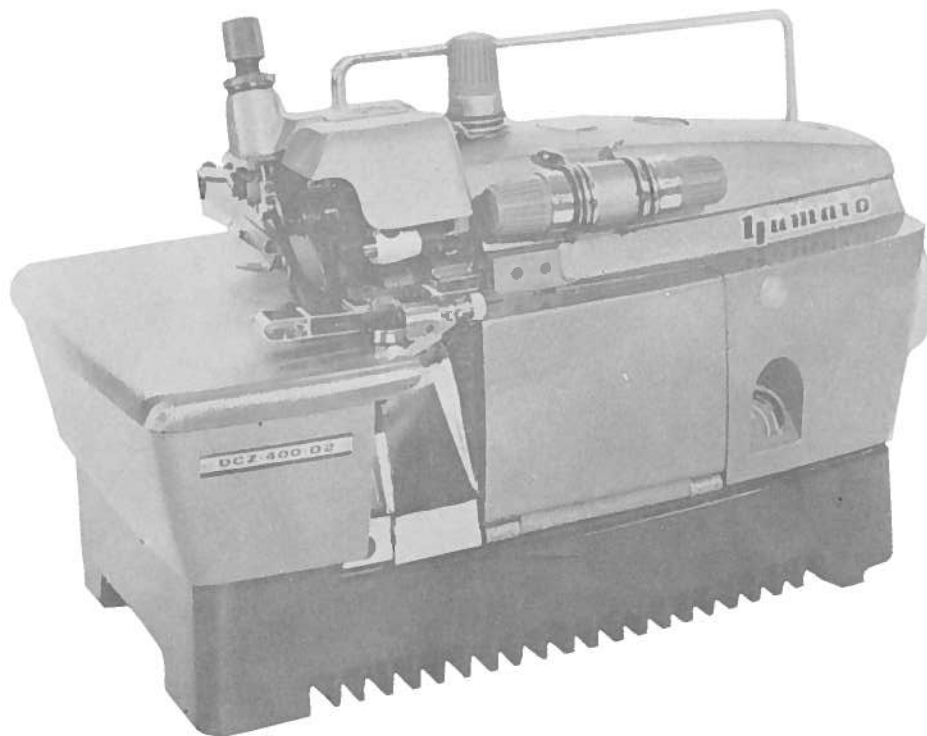

MODEL

DCZ-400 DCZ-401 DCZ-403 DCZ-406 DCZ-410
DCZ-414 DCZ-445 —K— —C— —V—

KONDO SEWING MACHINE CO.,LTD.

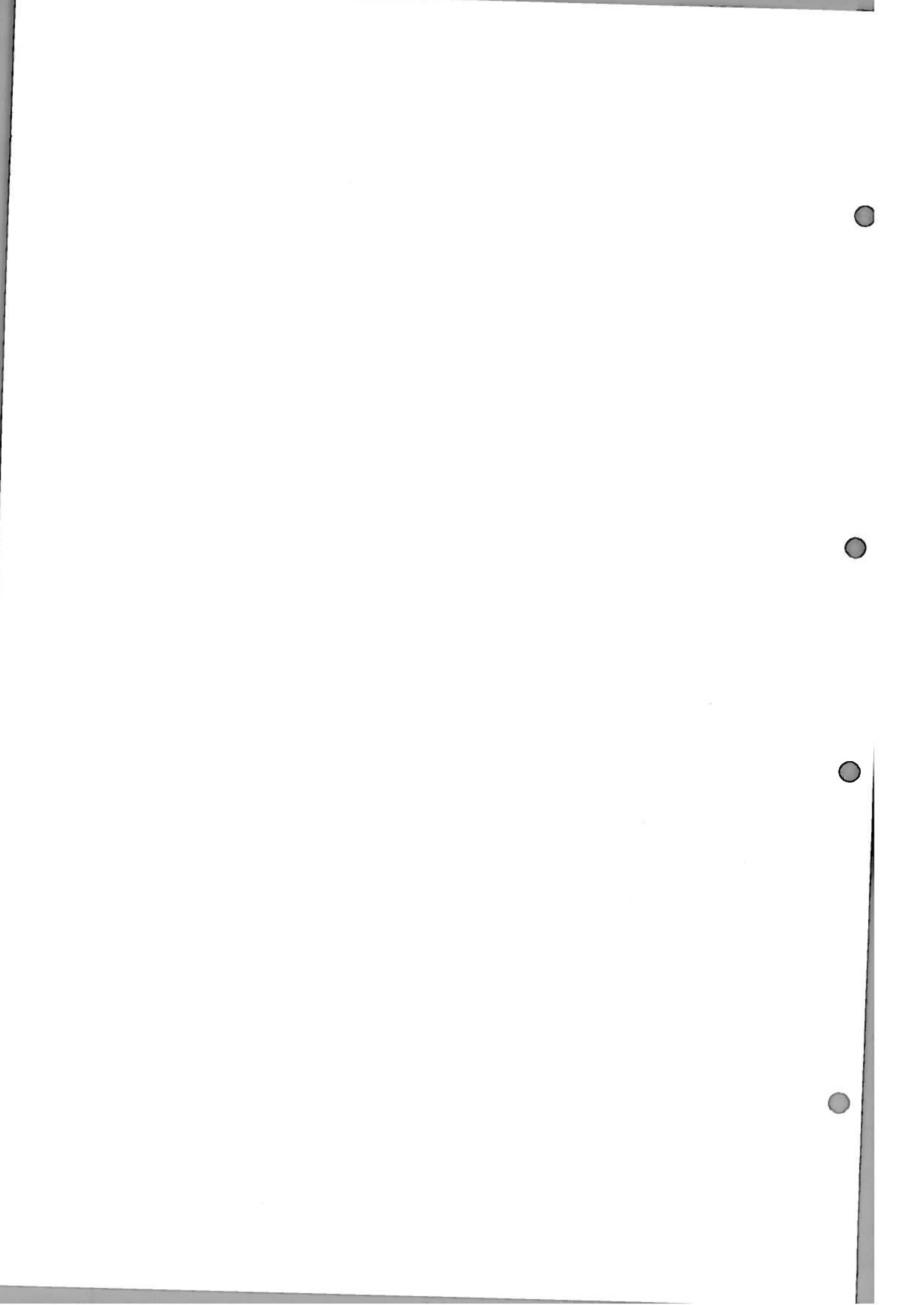

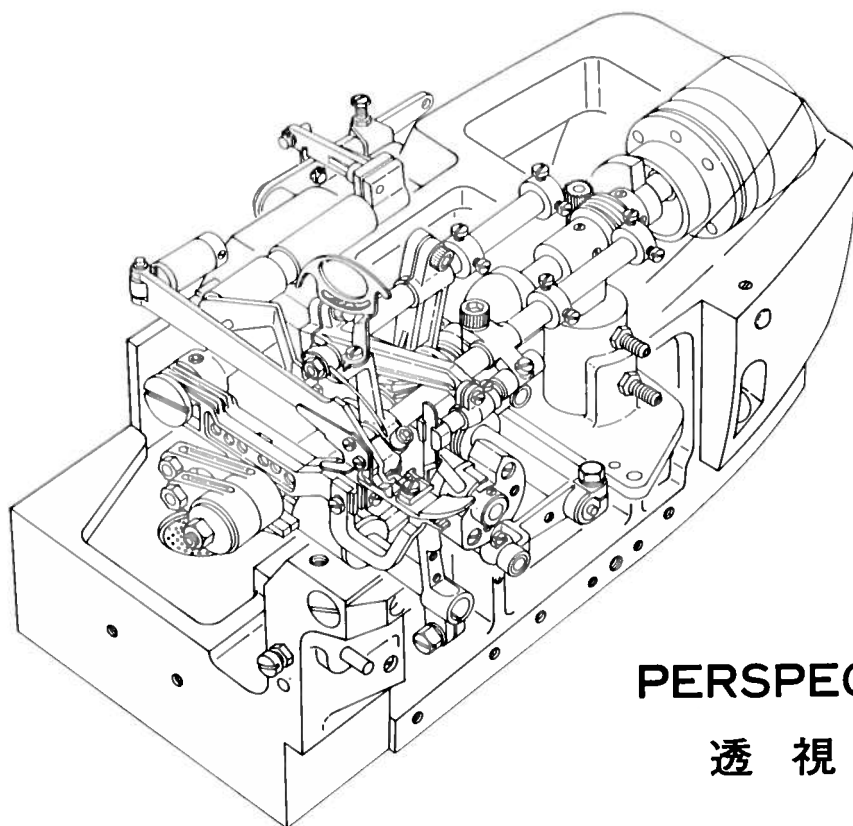

PERSPECTIVE

透視図

CONTENTS

目次

MISCELLANEOUS COVER	カバー関係……………1
TOP COVER & NEEDLE THREAD EYELET	上カバー、針糸道関係……………2
COVER, THREAD EYELET & FRAME	カバー、糸道、ベース関係……………3
MISCELLANEOUS BUSHING & CRANKSHAFT	ブッシュ主軸関係……………4
NEEDLE DRIVING ARM & KNIFE DRIVING MECHANISM	針振り腕、メス機構……………5
LOOPER DRIVING MECHANISM	ルーパー機構……………6
PRESSER FOOT MECHANISM	押工機構……………7
FEED DRIVING MECHANISM	送り機構……………8
OIL LUBRICATING SYSTEM	給油関係……………9
DCZ-401, -403, -406, -410, -445 EXCLUSIVE PARTS	サブクラス専用部品……………10
DCZ-400K, -401K, -403K, -414K EXCLUSIVE PARTS	サブクラス専用部品……………11
“C” & “V” DEVICE	“C”及び“V”装置……………12
ACCESSORY	アクセサリ関係……………13
INDEX	索引……………14



Please always mention our parts number when placing your orders.
部品の御注文は部品番号で!!

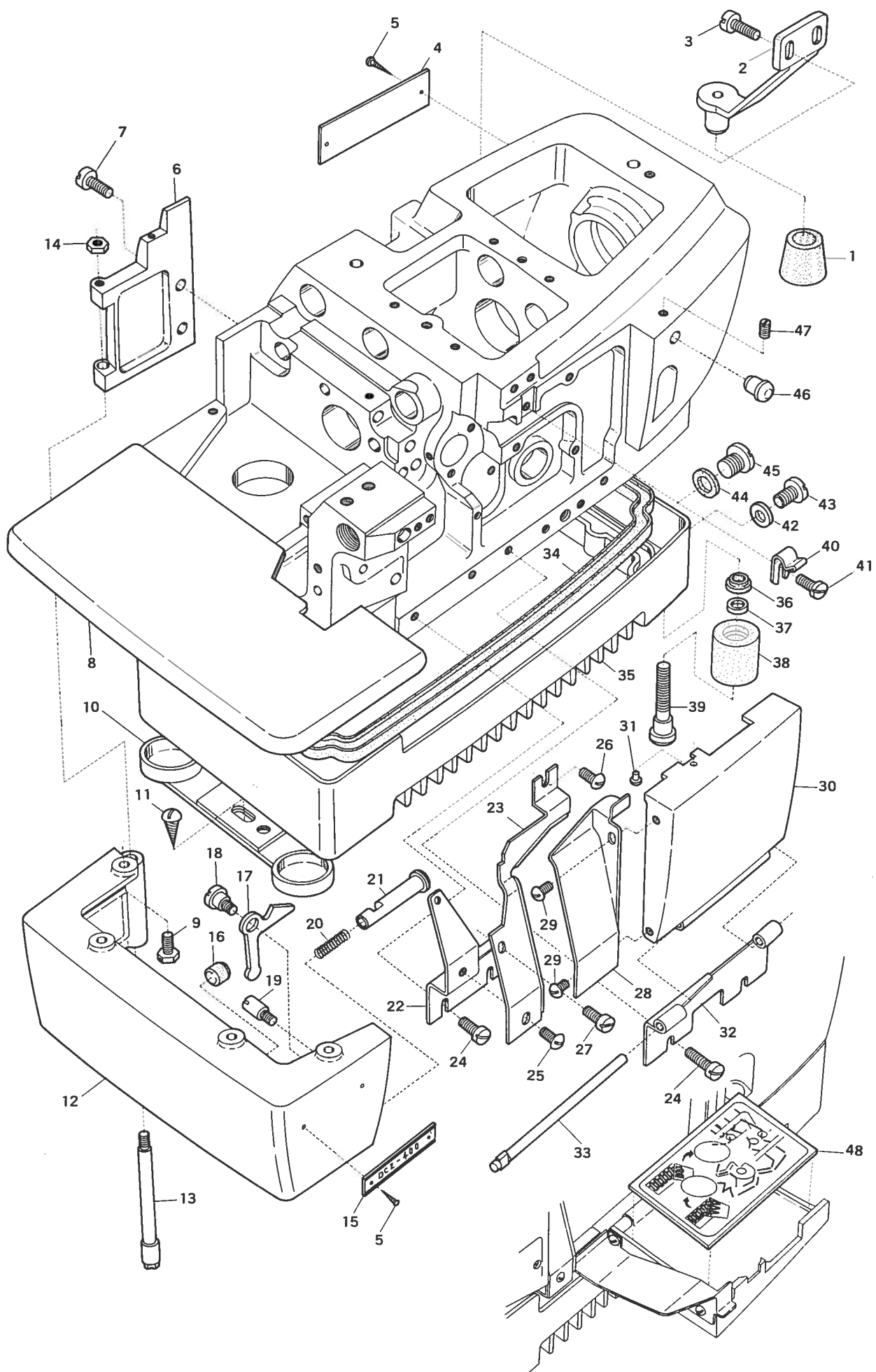

MISCELLANEOUS COVER

カバー関係

1

Ref. No.	Parts No.	Description	品名	Amt. Req.
1	32976	Stay Rubber Cushion	支工具ゴム座	1
2	32977	Frame Stay	ベッド支工具	1
3	9150	Screws for 32977	ベッド支工具止ネジ	2
4	977	Name Plate	ベッド社名板	1
5	726	Rivets for Name Plate & Model Indicate Plate	リベット	4
6	34298	Cloth Plate Hinge	横カバーヒンジ	1
7	5089	Screws for 34298	横カバーヒンジ止ネジ	2
8	34297	Cloth Plate (Upper)	大カバー	1
9	7605	Screws for 34297	大カバー止ネジ	4
10	34021	Rubber Cushion Holder Plate	ベースプレート (組)	1
11	6910	Screws for 34021	ベースプレート (組) 止ネジ	4
12	34003	Cloth Plate (Lower)	横カバー	1
13	32586	Cloth Plate Hinge Pin	横カバーヒンジピン	1
14	334	Nut for 32586	横カバーヒンジピンナット	1
15		Model Indicate Plate	型式板	1
16	32604	Cloth Plate Rubber Cushion	埋メ座 (大)	1
17	30126	Cloth Plate Latch	横カバーフック	1
18	6040	Screw for 30126	横カバーフック止ネジ	1
19	5095	Stopper for 30126	横カバーフックストッパー	1
20	34018	Cloth Plate Latch Spring	横カバーバネ	1
21	34012	Cloth Plate Latch Plunger	横カバーピン	1
22	34011	Chip Guard Supporter	切屑落シ取付板	1
23	32610	Chip Guard (Fix)	切屑落シ板 (大)	1
24	4440	Screws for 34011, 34008	止ネジ	2
25	1330	Screw for 32610	切屑落シ板 (大) 止ネジ	1
26	1326	Screw for 32610	切屑落シ板 (大) 止ネジ	1
27	1222	Screw for 32610	切屑落シ板 (大) 止ネジ	1
28	32611	Chip Guard (Open)	切屑落シ板 (小)	2
29	5131	Screw for 32611	切屑落シ板 (小) 止ネジ	1
30	34007	Front Cover	前開キカバー	1
31	727	Front Cover Latch	前開キカバーバネ掛ケピン	1
32	34008	Front Cover Hinge	前開キカバーヒンジ	1
33	34039	Front Cover Hinge Pin	前開キカバーピン	1
34	34014	Base Gasket	ベースパッキン	1
35	34005	Base	ベース	1
36	32375	Base Oil Seals	ベース止ネジパッキン	4
37	563	Washers for 32375	ベース止ネジ座金	4
38	32377	Base Rubber Cushions	ベースゴム座	4
39	6262	Screws for 34005	ベース止ネジ	4
40	32609	Front Cover Latch Spring	前開キカバーバネ	1
41	4358	Screw for 32609	前開キカバーバネ止ネジ	1
42	567	Drain Hole Seal for Outer	ベース油抜キパッキン (小)	1
43	9852	Drain Hole Screw for Outer	ベース油抜キネジ (小)	1
44	32421	Drain Hole Seal for Inner	Oリング	1
45	5076	Drain Hole Screw for Inner	ベース油抜キネジ (大)	1
46	32612	Front Seal Plug	結栓	1
47	3434	Screw for 32612	結栓止ネジ	1
48	839	Threading Chart for DCZ-400	糸通シ図	1

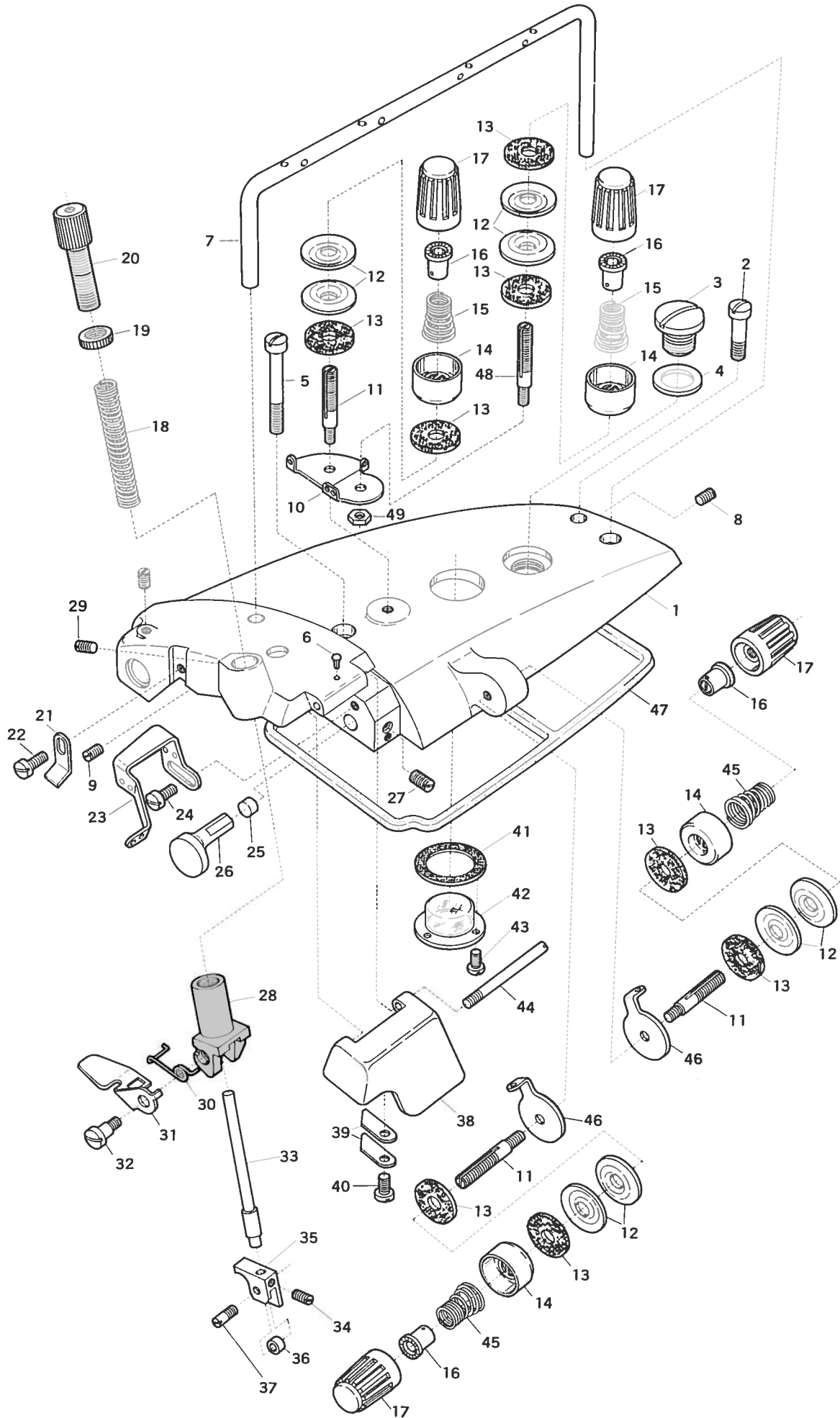

TOP COVER & NEEDLE THREAD EYELET

上カバー、針糸道関係 2

Ref. No.	Parts No.	Description	品名	Amt. Req.
1	34040	Top Cover	上カバー	1
2	5003	Screw for 34040	上カバー止ネジ	1
3	5077	Oil Cap Screw	上カバー注油蓋ネジ	1
4	529	Seal for 5077	油入レネジパッキン	1
5	5002	Screw for 34040	上カバー止ネジ	1
6	726	Top Front Cover Latch	止メ鉄	1
7	34220	Thread Lead Bar	糸道棒	1
8	3433	Screw for 34220	糸道棒止ネジ	1
9	9209	Screw for 34220	糸道棒止ネジ	1
10	32962	Needle Thread Tension Disc Eyelet	調子台糸道	1
11	6542	Tension Posts	糸調子棒	3
12	01111	Tension Discs	糸調子皿	6
13	286	Felts for Tension Post	フェルト (調子皿)	6
14	37635	Thread Tension Spring Retainers	渦巻キバネキャップ (下)	3
15	32971	Needle Thread Tension Spring	渦巻キバネ (大)	1
16	30254	Tension Spring Bushings	糸調子ナット廻り止メ (組)	3
17	32965	Thread Tension Spring Caps	渦巻キバネキャップ (上)	3
18	34288	Presser Spring	押エバネ	1
19	461	Presser Spring Lock Nut	押エバネ調節ネジナット	1
20	6403	Adjust Screw for 34288	押エバネ調節ネジ	1
21	34219	Presser Arm Stopper	押エ台ストッパー	1
22	4353	Screw for 34219	押エ台ストッパー止ネジ	1
23	34222	Needle Thread Eyelet	針糸道	1
24	1175	Screws for 34222	針糸道止ネジ	2
25	32519	Upper Knife Driving Arm Guide Plug	上メス台案内詰栓	1
26	33142	Upper Knife Driving Arm Guide	上メス台案内	1
27	9200	Screw for 33142	上メス台止ネジ	1
28	34280	Presser Foot Spring Holder	押エバネホルダー	1
29	1448	Screw for 34280	押エバネホルダー止ネジ	1
30	34295	Presser Foot Release Lever Spring	手揚ゲバネ	1
31	34289	Presser Foot Release Lever	手揚ゲ	1
32	6004	Screw for 34289	手揚ゲ止ネジ	1
33	34296	Presser Foot Positioning Pin	押エバネガイドピン	1
34	1459	Screws for 34296, 34281	止ネジ	2
35	34281	Presser Foot Positioning Guide	押エ台ガイド	1
36	34294	Presser Foot Roller	押エローラー	1
37	6405	Screw for 34294	押エローラー止ネジ	1
38	34002	Top Front Cover	上メスカバー	1
39	34015	Top Front Cover Latch Spring	上メスカバーバネ	2
40	4358	Screw for 34015	上メスカバーバネ止ネジ	1
41	32924	Oil Sight Top Window Seal	油量観キャップパッキン	1
42	32930	Oil Sight Top Window	油量観キャップ	1
43	1333	Screws for 32930	油量観キャップ止ネジ	3
44	—	Top Front Cover Pin	上メスカバーピン	1
45	32952	Looper Thread Tension Spring	渦巻キバネ	1
46	34218	Looper Thread Tension Disc Eyelet (Upper)	ルーバー調子台糸道	1
47	34013	Top Cover Gasket	上カバーパッキン	1

3

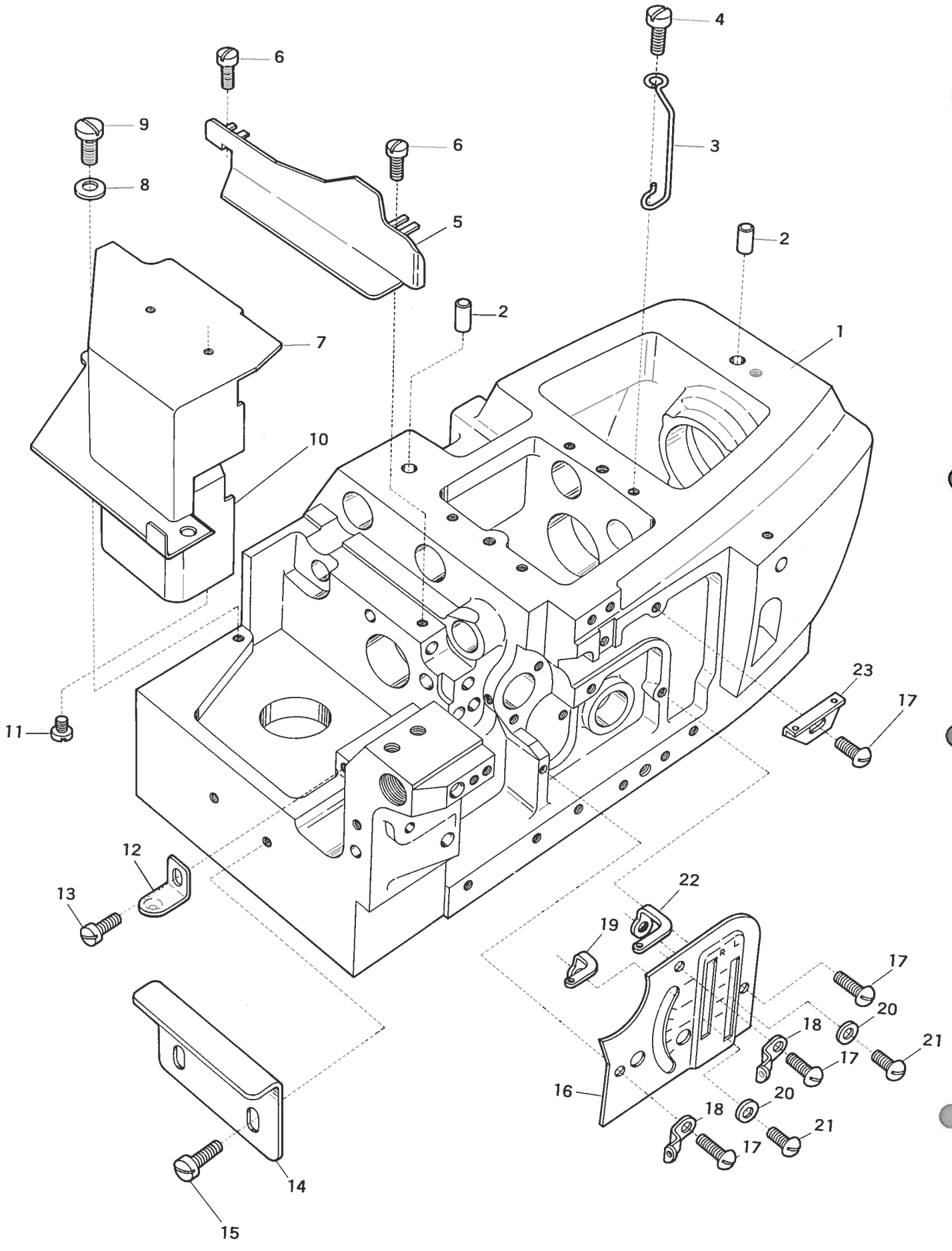

COVER, THREAD EYELET & FRAME

カバー、糸道、ベース関係 **3**

Ref. No.	Parts No.	Description	品名	Amt. Req.
			ベッド	1
1	34000	Frame	上カバー決メピン	2
2	34026	Top Cover Positioners	パイプ支エ	1
3	34205	Oil Tube Holder	パイプ支エ止ネジ	1
4	9853	Screw for 34205	布滑り案内板	1
5	34299	Fabric Guard	布滑り案内板止ネジ	2
6	4353	Screws for 34299	送りリンクカバー	1
7	34017	Feed Mechanism Cover	送りリンクカバー座金	1
8	10	Washer for 34017	送りリンクカバー止ネジ	1
9	6004	Hinge Screw for 34017	送りリンクカバー (小)	1
10	34045	Feed Mechanism Oil Shield	送りリンクカバー (小) 止ネジ	2
11	1228	Screws for 34045	送りリンクカバーバネ	1
12	34626	Feed Mechanism Cover Latch Spring	送りリンクカバーバネ止ネジ	1
13	4351	Screw for 34626	横カバーガードプレート	1
14	34019	Cloth Plate Guard	横カバーガードプレート止ネジ	2
15	9150	Screws for 34019	前カバー	1
16	34229	Looper Thread Eyelet Supporter	前カバー止ネジ	4
17	1326	Screws for 34229, 34225	下ルーバー糸道	1
18	32960	Lower Looper Thread Eyelet	ルーバー糸道 (左)	1
19	32958	Looper Thread Eyelet (Left)	ルーバー糸道座金	2
20	532	Washers for 32958, 32955	ルーバー糸道止ネジ	2
21	1330	Screws for 32958, 32955	ルーバー糸道 (右)	1
22	32955	Looper Thread Eyelet (Right)	ルーバー糸道	1
23	34225	Looper Thread Tension Disc Eyelet (Lower)		

4

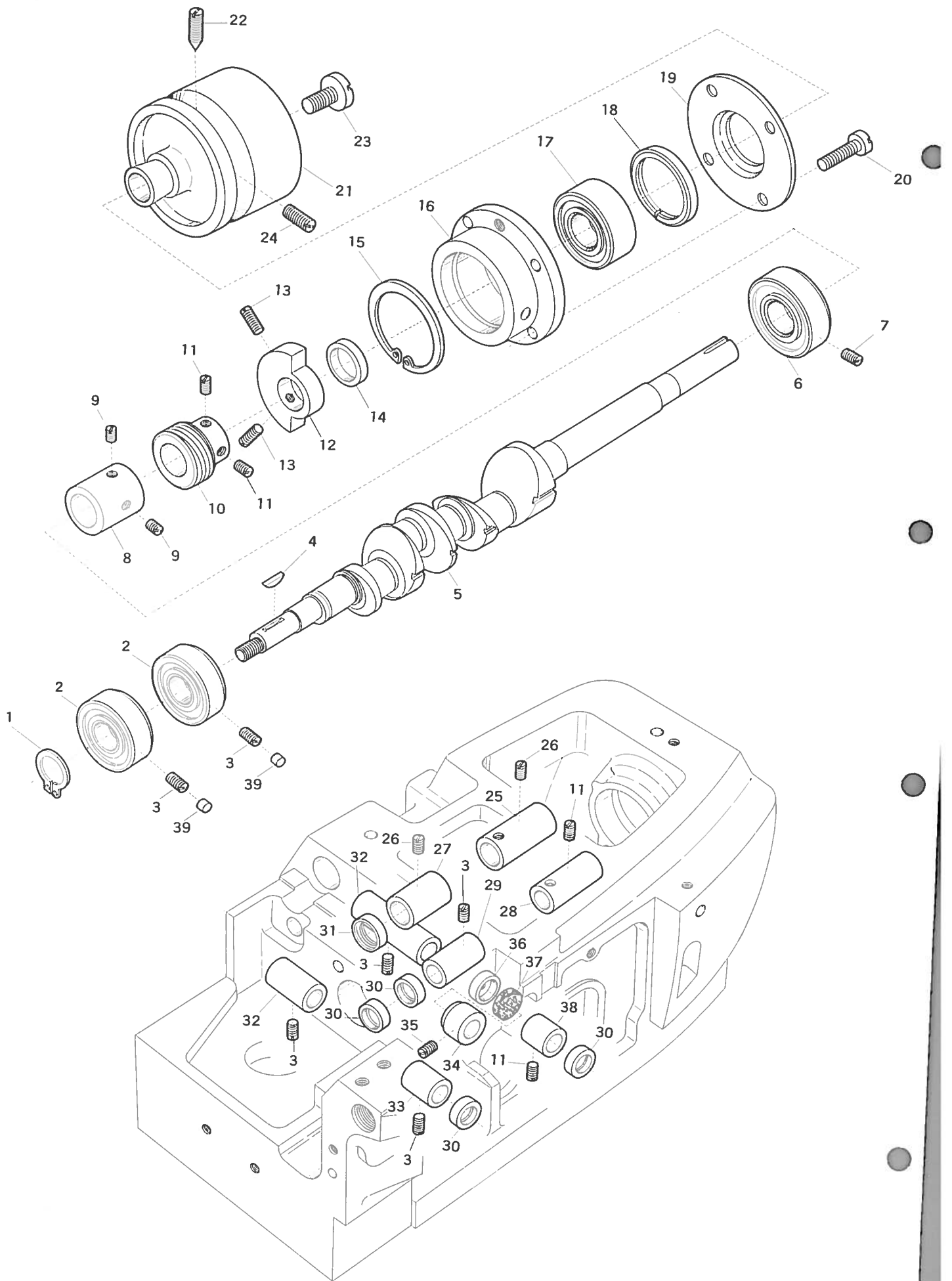

Ref. No.	Parts No.	Description	品 名	Amt. Req.
1	34117	Retaining Ring for 34092	ストップリング	1
2	34092	Crankshaft Ball Bearing	ボールベアリング	2
3	9209	Screws for 34092, 33070, 34116, 34114	止ネジ	6
4	34096	Feed Driving Eccentric Key	キー	1
5	34195	Crankshaft	クランクシャフト	1
6	34091	Crankshaft Ball Bearing (Inner)	ボールベアリング	1
7	3436	Screw for 34091	ボールベアリング止ネジ	1
8	34115	Retaining Collar for 34091	ベアリング抜き止メ	1
9	3433	Screws for 34115	ベアリング抜き止メネジ	2
10	32925	Oil Pump Driving Worm	ウオーム	1
11	7650	Screws for 32925, 34054, 34098	止ネジ	4
12	33077	Crankshaft Counterweight	バランスウェイト (右)	1
13	1435	Screws for 33077	バランスウェイト止ネジ	2
14	32779	Retaining Washer for 32777	ベアリング位置決めリング	1
15	32778	Inner Retaining Ring for 32777	ストップリング	1
16	32775	Crankshaft Ball Bearing Housing	大ブッシュ	1
17	32777	Crankshaft Ball Bearing (Right)	ボールベアリング	1
18	32818	Outer Retaining Ring for 32777	ボールベアリング押工	1
19	32817	Crankshaft Ball Bearing Housing Cap	大ブッシュ蓋	1
20	4441	Screws for 32817	大ブッシュ蓋止ネジ	4
21	34094	Pulley	プーリー	1
22	9202	Main Screw for 34094	プーリー決めネジ	1
23	4402	Cap Screw for 34094	プーリー位置決めネジ	1
24	5006	Sub Screw for 34094	プーリー止ネジ	1
25	34192	Upper Knife Driving Shaft Bushing (Right)	上メスブッシュ (右)	1
26	1457	Screws for 34192, 34193	止ネジ	2
27	34193	Upper Knife Driving Shaft Bushing (Left)	上メスブッシュ (左)	1
28	34054	Needle Driving Shaft Bushing (Right)	針振り軸ブッシュ (右)	1
29	33070	Needle Driving Shaft Bushing (Left)	ルーバー前後軸ブッシュ (左)	1
30	30291	Needle & Looper Shaft Oil Seal	オイルシール	4
31	32684	Upper Knife Driving Shaft Oil Seal	針棒クランク軸オイルシール	1
32	34116	Lower Looper Driving Shaft Bushings (Rear)	下ルーバー軸ブッシュ (後)	2
33	34114	Lower Looper Driving Shaft Bushing (Front)	下ルーバー軸ブッシュ (前)	1
34	34121	Upper Looper Bar Guide Bushing	ルーバー案内ブッシュ	1
35	1448	Screw for 34121	ルーバー案内ブッシュ止ネジ	1
36	34347	Upper Looper Bar Guide Bushing Cap	ルーバー案内ブッシュ蓋	1
37	518	Oil Felt for 34347	ルーバー案内ブッシュ蓋フェルト	1
38	34098	Upper Looper Driving Shaft (Front)	上ルーバー軸ブッシュ (前)	1
39	38221	Seal Plugs for 34054	埋メ座	2

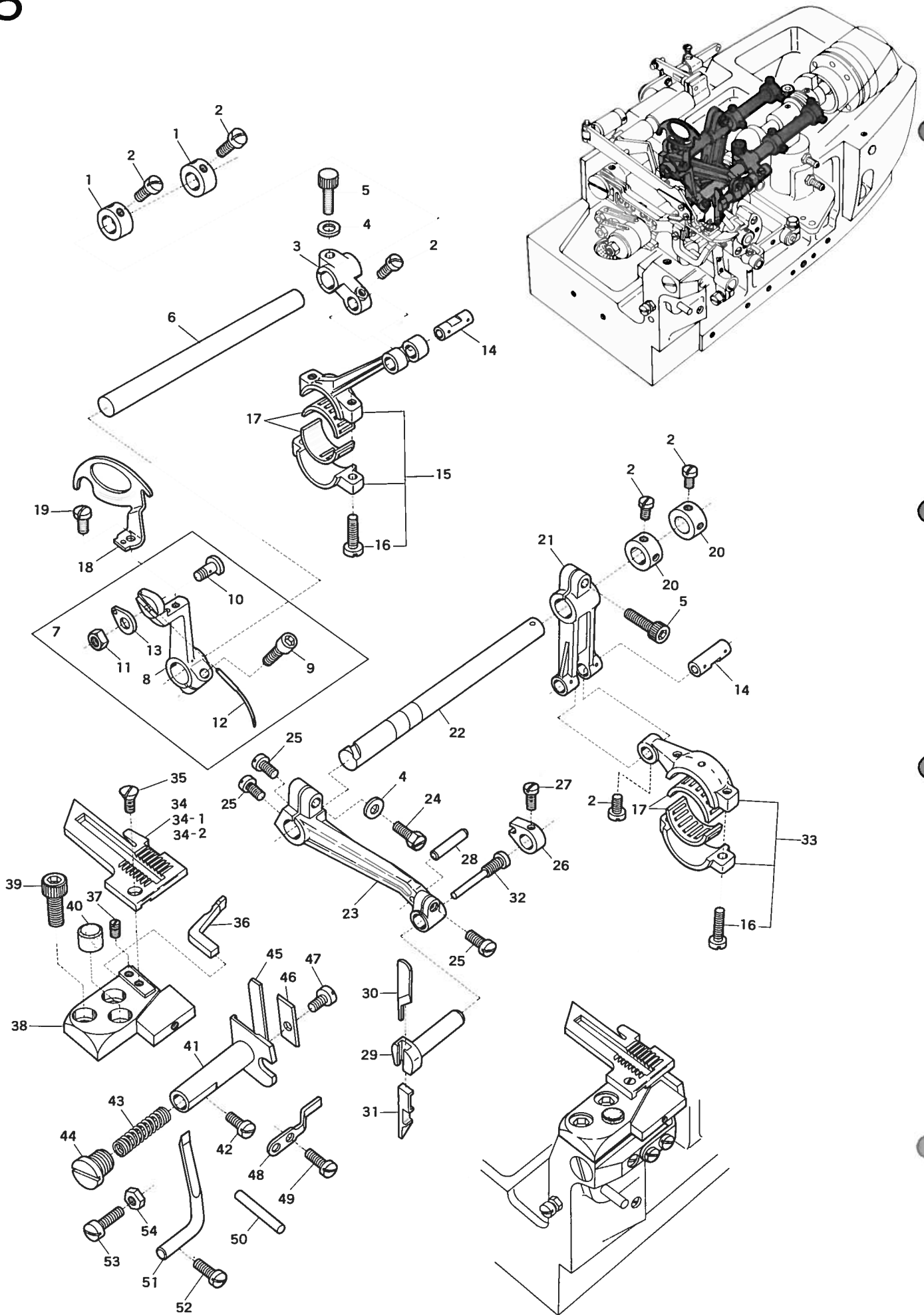

Ref. No.	Parts No.	Description	品 名	Amt. Req.
1	30228	Needle Driving Shaft Collars	針振り軸カラー	2
2	9604	Screws for 30228, 32646, 34051	止ネジ	10
3	34052	Needle Driving Shaft Lever	針振り軸腕	1
4	520	Washers for 34052, 34194	座金	2
5	5520	Screws for 34052, 32902	止ネジ	2
6	34053	Needle Driving Shaft	針振り軸	1
7	34399	Needle Driving Arm Complete Set	針振り腕 (組)	1
8	34055	Needle Driving Arm	針振り腕	1
9	5550	Screw for 34055	針振り腕止ネジ	1
10	34056	Needle Clamp Stud	針止メピン	1
11	355	Nut for 34056	針止メピンナット	1
12		Needle (Uy 154 GAS)	針	1
13	34060	Needle Clamp Washer	針押工	2
14	34051	Connecting Rod Pins	ロットピン	1
15	34050	Needle Driving Connecting Rod	針振りロット	4
16	5070	Screws for 34050, 34190	止ネジ	2
17	32819	Connecting Rod Roller Bearings	ニードルヘアリンク	1
18	34223	Needle Thread Pull-Off	針糸繰り	1
19	4358	Screw for 34223	針糸繰り止ネジ	1
20	32646	Upper Knife Driving Shaft Collars	上メス軸カラー	2
21	32902	Upper Knife Driving Lever	上メス軸腕	1
22	32903	Upper Knife Driving Shaft	上メス軸	1
23	34194	Upper Knife Driving	上メス台	1
24	5522	Screw for 34194	上メス台止ネジ	1
25	8163	Screws for 32911, 34194	止ネジ	3
26	32912	Upper Knife Holder Guide	上メス案内	1
27	7616	Screw for 32912	上メス案内止ネジ	1
28	723	Guide Pin for 32912	上メス案内ピン	1
29	32911	Upper Knife Holder	上メス抱キ	1
30	32914	Upper Knife	上メス	1
31	32913	Upper Knife Clamp	上メス押シ	1
32	5508	Screw for 32913	上メス押シ止ネジ	1
33	34190	Upper Knife Driving Connecting Rod	上メスロット	1
34	32666	Throat Plate #1	針板#1	1
34-1	32667	Throat Plate #2	針板#2	1
34-2	32682	Throat Plate #3	針板#3	1
35	5401	Screw for Throat Plate	針板止ネジ	1
36	34058	Needle Guard (Rear)	針受ケ (後)	1
37	7650	Screw for 34058	針受ケ (後) 止ネジ	1
38	34025	Throat Plate Supporter	針板受ケ	1
39	6662	Screws for 34025	針板受ケ止ネジ	2
40	32604	Cloth Plate Rubber Cushion	埋メ座 (大)	1
41	32916	Lower Knife Holder	下メス台	1
42	4591	Screw for 32916	下メス台止ネジ	1
43	32919	Lower Knife Holder Spring	下メスバネ	1
44	5074	Screw for 32919	下メスバネ止ネジ	1
45	30421	Lower Knife	下メス	1
46	32917	Lower Knife Clamp	下メス押工	1
47	4353	Screw for 32917	下メス押工止ネジ	1
48	32899	Lower Knife Holder Locking Plate	下メス台廻り止メ	1
49	4440	Screws for 32899	下メス台廻り止メ止ネジ	2
50	698	Cloth Plate Latch Pin	フック掛ケピン	1
51	34057	Needle Guard (Front)	針受ケ (前)	1
52	4437	Screw for 34057	針受ケ (前) 止ネジ	1
53	5043	Stopper Screw for Cloth Plate	大カバーストップバーネジ	1
54	340	Nut for 5043	大カバーストップバーネジナット	1

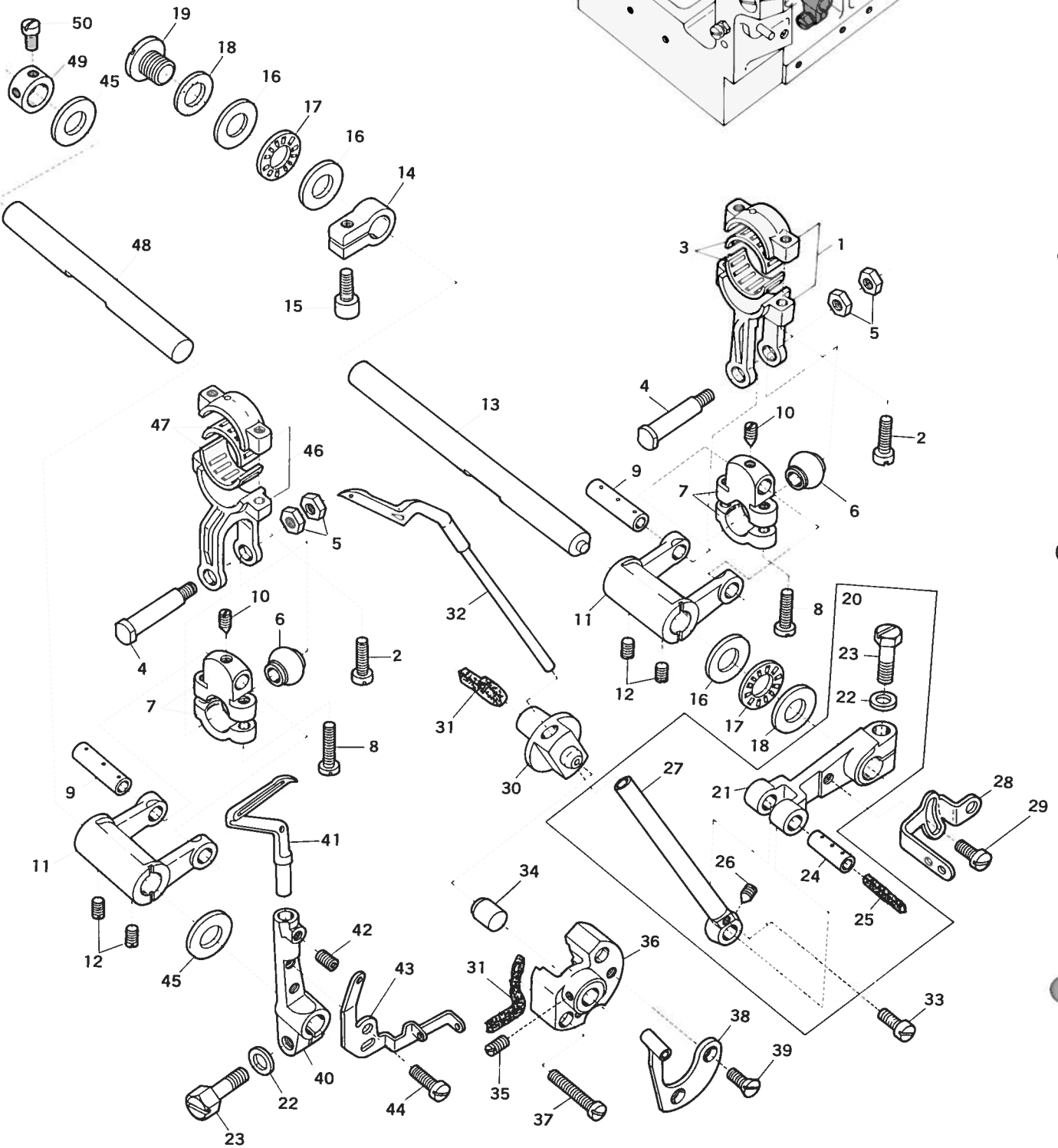
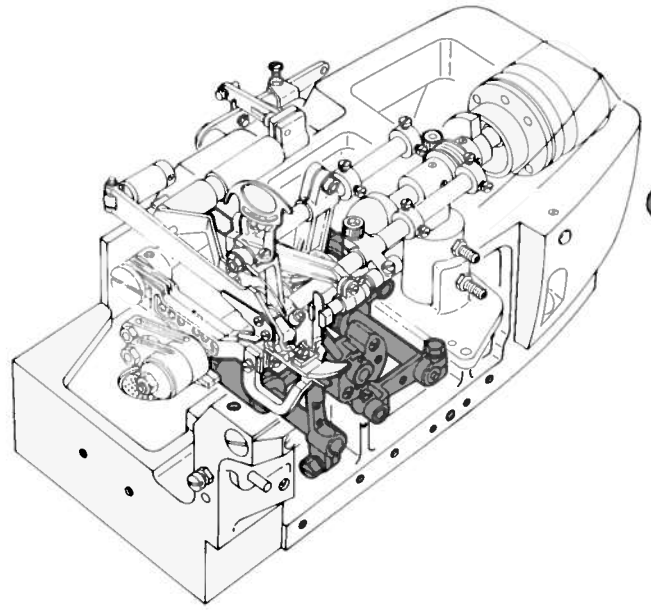

LOOPER DRIVING MECHANISM

ルーパー機構

6

Amt.
Req.

Ref. No.	Parts No.	Description	品名	Amt. Req.
1	34196	Upper Looper Connecting Rod	上ルーパーロッド	1
2	5070	Screws for 34196, 34101	ルーパーロッド止ネジ	4
3	34197	Connecting Rod Roller Bearing	ニードルベアリング	1
4	34103	Ball Clamp Studs	球固定ピン	2
5	340	Nuts for 34103	球固定ピンナット	4
6	34102	Balls	球	2
7	34100	Looper Driving Lever Links	ルーパーリンク	2
8	2043	Screws for 34100	ルーパーリンク止ネジ	4
9	32786	Looper Driving Lever Link Pins	ルーパーリンクピン	2
10	3404	Screws for 32785	ルーパーリンクピン止ネジ	2
11	34099	Looper Driving Lever	ルーパー軸腕	2
12	3635	Screws for 34099	ルーパー軸腕	4
13	34097	Upper Looper Driving Shaft	上ルーパー軸	1
14	32792	Upper Looper Driving Shaft Collar	上ルーパー軸カラー	1
15	5550	Screw for 32792	上ルーパー軸カラー止ネジ	1
16	32848	Upper Looper Driving Shaft Thrust Washers	スラストプレート	4
17	32849	Upper Looper Driving Shaft Thrust Plates	スラストコロ	2
18	606	Oil Shield	パッキン	1
19	6007	Upper Looper Driving Shaft End Cap Screw	上ルーパー軸蓋止ネジ	1
20	34479	Upper Looper Bar Driving Arm Complete Set	上ルーパークランク (組)	1
21	34104	Upper Looper Bar Driving Arm	上ル パークランク	1
22	520	Washers for 34104, 32789	座金	2
23	5500	Screws for 34104, 32789	止ネジ	2
24	34122	Upper Looper Bar Driving Arm Pin	ルーパークランクピン	1
25	282	Oil Wick for 34122	油芯	1
26	3311	Screw for 34122	ルーパークランクピン	1
27	34105	Upper Looper Bar	ルーパー棒	1
28	34230	Looper Thread Pull-Off (Right)	ルーパー糸繰り (右)	1
29	4358	Screw for 34230	ルーパー糸繰り (右) 止ネジ	1
30	34217	Upper Looper Bar Guide	ルーパー案内	1
31	304	Oil Wicks for 34106, 34107	油芯	2
32	34113	Upper Looper	上ルーパー	1
33	7302	Screw for 34113	上ルーパー止ネジ	1
34	34587	Upper Looper Bar Guide Thrust Pin	ルーパー案内決メピン	1
35	7650	Screw for 34109	ルーパー案内決メピン止ネジ	1
36	34516	Upper Looper Bar Guide Retainer	ルーパー案内蓋	1
37	5004	Screws for 34107	ルーパー案内蓋止ネジ	2
38	34226	Upper Looper Thread Guide	上ルーパー糸道 (組)	1
39	9142	Screw for 34226	上ルーパー糸道 (組) 止ネジ	2
40	32789	Lower Looper Holder Arm	下ルーパー台	1
41	34392	Lower Looper	下ルーパー	1
42	3638	Screw for 34392	下ルーパー止ネジ	1
43	34228	Looper Thread Pull-Off (Left)	ルーパー糸繰り (左)	1
44	1326	Screws for 34228	ルーパー糸繰り (左) 止ネジ	2
45	34118	Lower Looper Driving Shaft Thrust Washers	スラストプレート	2
46	34101	Looper Driving Lever Connecting Rod	ルーパーロッド	1
47	32819	Connecting Rod Roller Bearing	ニードルベアリング	1
48	34111	Lower Looper Driving Shaft	下ルーパー軸	1
49	30228	Lower Looper Driving Shaft Collar	下ルーパー軸カラー	1
50	9604	Screws for 30228	下ルーパー軸カラー止ネジ	2

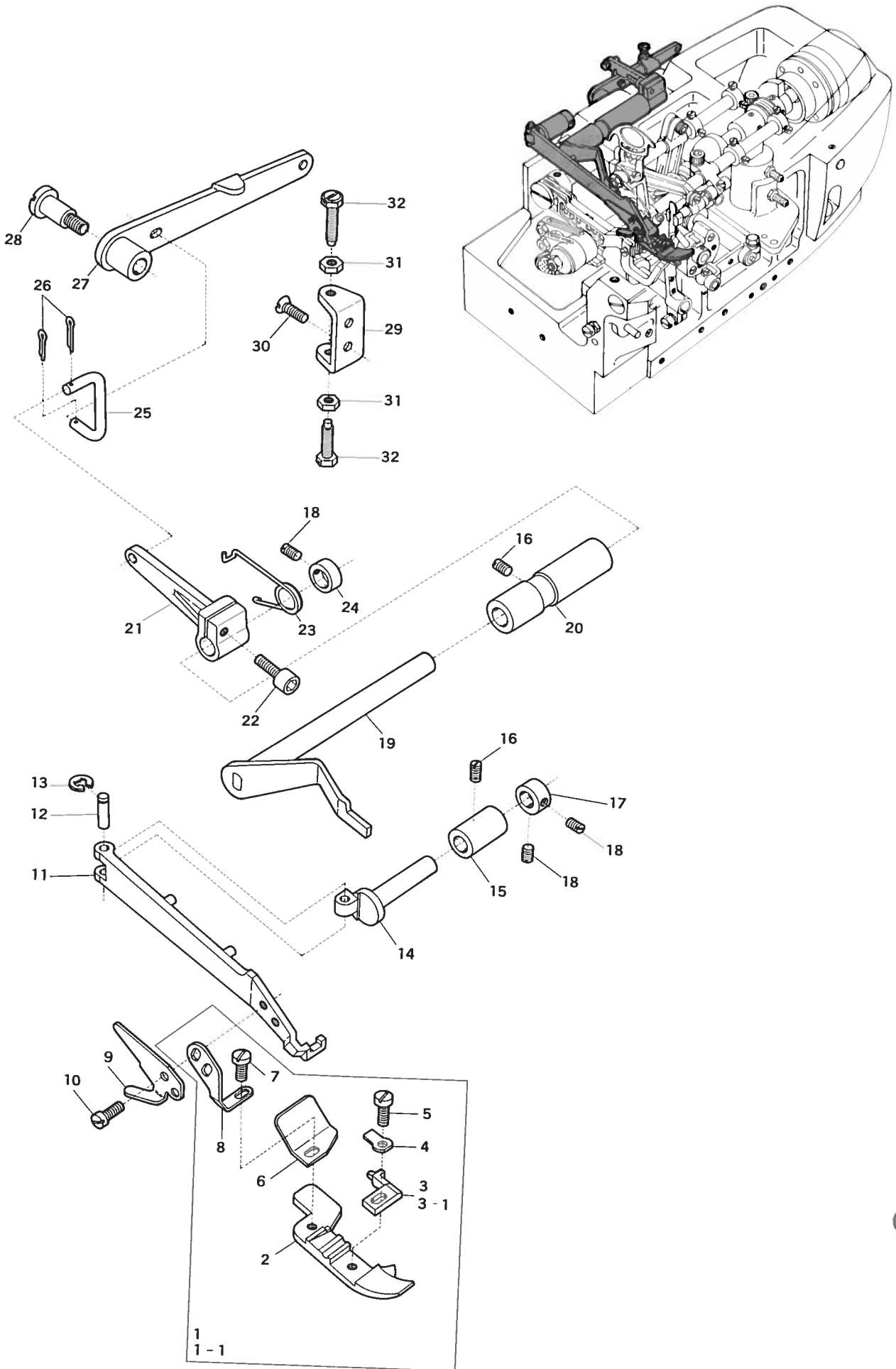

PRESSER FOOT MECHANISM

押工機構

7

Ref. No.	Parts No.	Description	品名	Amt. Req.
1	34079	Presser Foot Complete Set #1	押工 (組) #1	1
1-1	34080	Presser Foot Complete Set #2, #3	押工 (組) #2、#3	1
2	32736	Presser Foot	押工 (下)	1
3	32744	Presser Foot Stitch Tongue #1	爪 #1	1
3-1	32743	Presser Foot Stitch Tongue #2, #3	爪 #2、#3	1
4	30619	Presser Foot Hinge Spring	押工ヒンジバネ	1
5	5036	Screw for 30619	押工ヒンジバネ止ネジ	1
6	34535	Presser Foot Chain Shield	空糸押工	1
7	1230	Screw for 34535	空糸押工止ネジ	1
8	34292	Presser Foot Stay	押工固定片	1
9	34706	Chain Cutting Knife	チェンカッター	1
10	4404	Screws for 34706	チェンカッター止ネジ	2
11	34386	Presser Arm	押工台	1
12	34290	Presser Arm Hinge Pin	押工台ヒンジピン	1
13	1892	Presser Arm Hinge Pin Retaining Ring	ストップリング	1
14	34278	Presser Arm Shaft	押工軸	1
15	34287	Presser Arm Shaft Bushing	押工軸ブッシュ	1
16	9200	Screw for 34287, 34284	止ネジ	2
17	34302	Presser Arm Shaft Collar	押工軸カラー	1
18	1459	Screws for 34302, 34719	止ネジ	4
19	34300	Foot Lifter Lever Shaft Complete Set	押工揚ゲ軸レバー (組)	1
20	34284	Foot Lifter Lever Shaft Bushing	押工揚ゲ軸ブッシュ	1
21	34283	Intermediate Lever (Large)	押工揚ゲ軸レバー (大)	1
22	5550	Screw for 34283	押工揚ゲ軸レバー (大) 止ネジ	1
23	34301	Intermediate Lever Spring	押工揚ゲ軸バネ	1
24	34719	Foot Lifter Small Collar	押工軸レバー止メカラー	1
25	34265	Foot Lifter Lever Connecting Link	押工レバー連結桿	1
26	32715	Cotter Pins	割ピン	1
27	32711	Foot Lifter Lever	押工揚ゲレバー	1
28	6000	Screw for 32711	押工揚ゲレバー止ネジ	1
29	32716	Foot Lifter Lever Stopper	押工揚ゲストッパー	1
30	9127	Screws for 32716	押工揚ゲストッパー止ネジ	2
31	340	Nuts for 32716	押工揚ゲストッパー調節ネジナット	2
32	5505	Adjust Screws for 32716	押工揚ゲストッパー調節ネジ	2

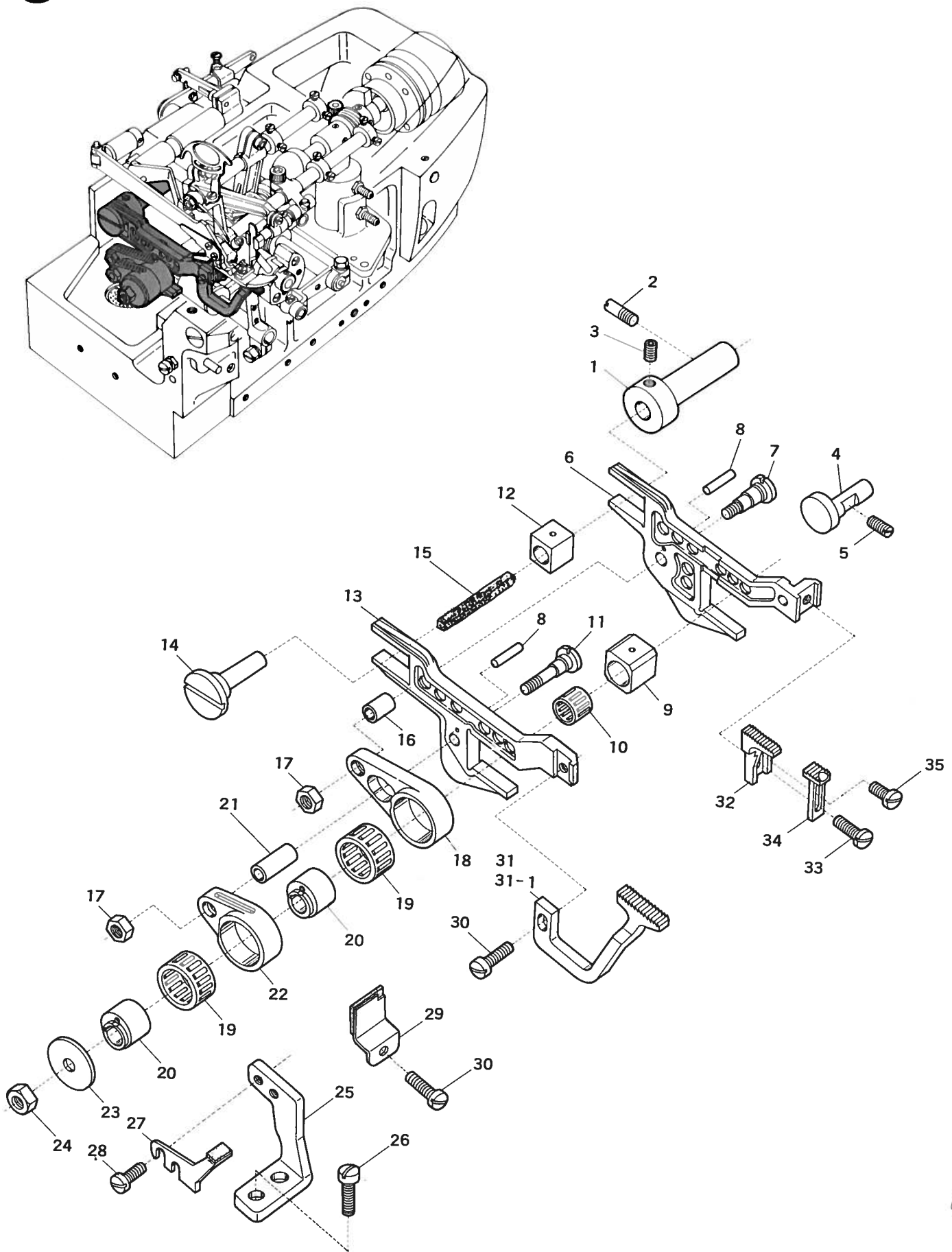

Ref. No.	Parts No.	Description	品名	Amt. Req.
1	34134	Feed Bar Guide (Rear)	送り台ガイド (後)	1
2	3632	Screw for 34134	送り台ガイド (後) 止ネジ	1
3	3635	Screw for 32866	エキセンピン止ネジ	1
4	34135	Feed Bar Guide (Right)	送り台ガイド (右)	1
5	9200	Screw for 34135	送り台ガイド (右) 止ネジ	1
6	34131	Main Feed Bar	後送り台	1
7	32864	Main Feed Bar Driving Stud	送りリンクピン	1
8	722	Cotters for 32864, 34138	送りリンクピンノックピン	2
9	34139	Feed Lift Block	角駒 (大)	1
10	34142	Feed Lift Block Roller Bearing	ニードルベアリング	1
11	34138	Differential Feed Bar Driving Stud	送りリンクピン	1
12	32867	Feed Bar Guide Block	角駒 (小)	1
13	34130	Differential Feed Bar	前送り台	1
14	32866	Feed Adjusting Pin	エキセンピン	1
15	291	Oil Wick for 32866	油芯	1
16	32853	Feed Bar Driving Connection Bushing	送りリンクブッシュ	1
17	451	Nuts for 32853, 34137	ナット	2
18	34133	Main Feed Bar Driving Connection	後送りリンク	1
19	34141	Feed Driving Eccentric Roller Bearings	ニードルベアリング	2
20	—	Feed Driving Eccentric (See Below The Table)	送り前後エキセン	1
21	34137	Differential Feed Bar Driving Connection Bushing	送りリンクブッシュ	1
22	34132	Differential Feed Bar Driving Connection	前送りリンク	1
23	605	Thrust Washer for 34141	座金	1
24	20	Nut for Feed Driving Eccentric	送り前後エキセンナット	1
25	34136	Feed Bar Guide (Left)	送り台ガイド (左)	1
26	4440	Screws for 34136	送り台ガイド (左) 止ネジ	1
27	34059	Throat Plate Stay	針板支工	1
28	5000	Screws for 34059	針板支工止ネジ	2
29	34020	Feed Bar Front Oil Shield Complete Set	送り前カバー (組)	1
30	4353	Screws for 34020, 33810, 33812	止ネジ	2
31	33812	Differential Feed Dog (Coarse Mesh)	前送り (並目)	2
31-1	33810	Differential Feed Dog	前送り	2
32	33811	Main Feed Dog	後送り	2
33	7609	Screw for 33811	後送り止ネジ	2
34	32883	Auxiliary Feed Dog	小送り	2
35	9730	Screw for 32883	小送り止ネジ	2

Feed Driving Eccentrics Table

PARTS No.	STITCHES PER INCH
34165	4
34145	5
34146	6
34147	7
34148	8
34149	9
34150	10
34151	11
34152	12
34153	13
34154	14
34155	15
34156	16
34157	17
34158	18
34159	19
34160	20
34161	22
34162	24
34163	26
34164	28
34166	30
34167	40
34168	50
34171	60
34170	70
34169	100

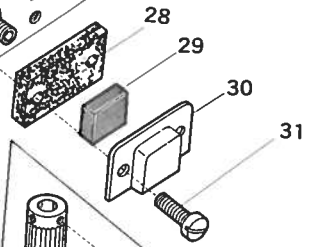
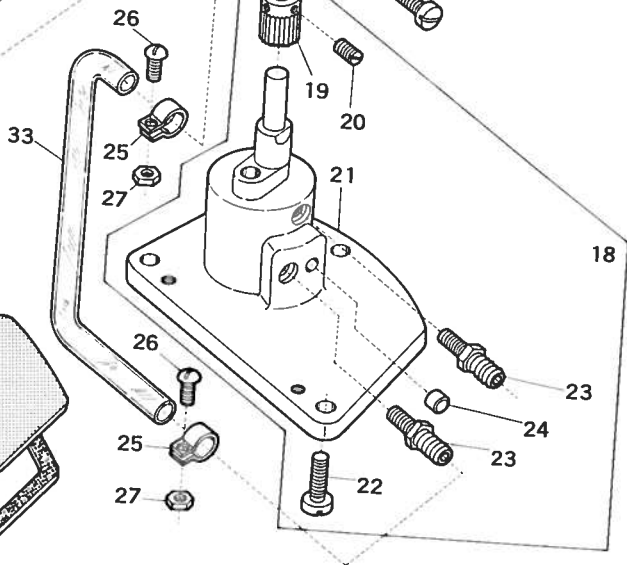
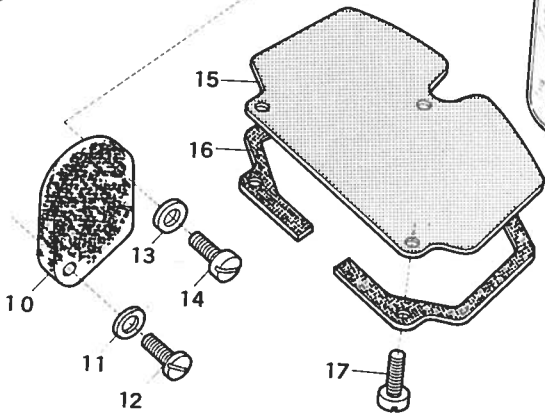
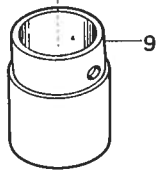
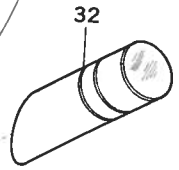
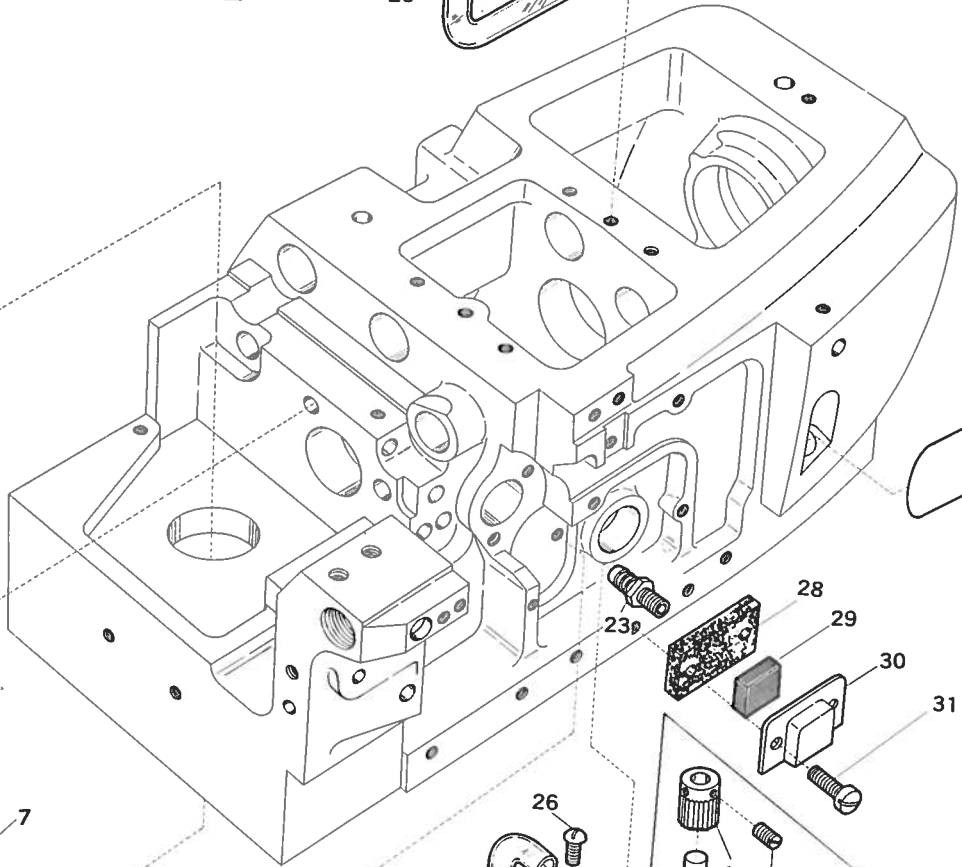
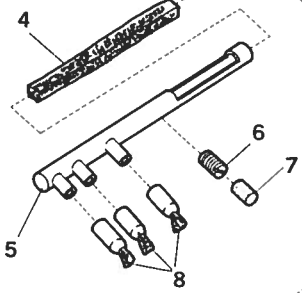
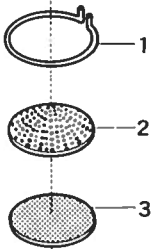
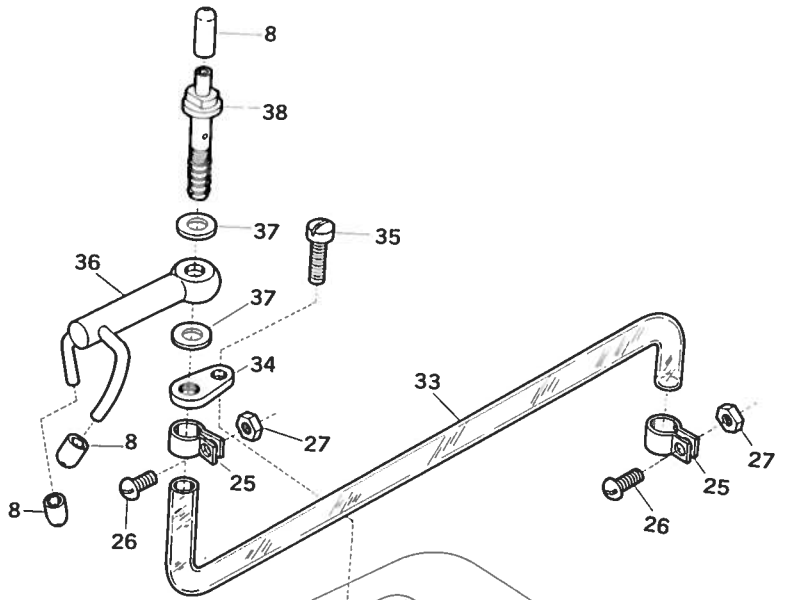
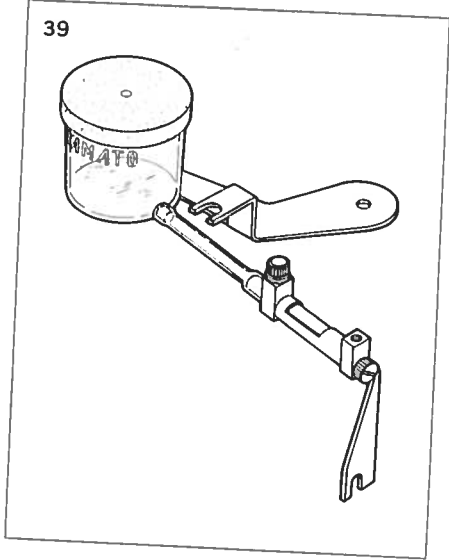

Ref. No.	Parts No.	Description	品名	Amt. Req.
1	32898	Round Oil Filter Screen Clamp (Upper)	濾過網押工 (小) 上	1
2	32933	Round Oil Filter Screen (Coarse Mesh)	濾過網 (荒目)	1
3	90951	Round Oil Filter Screen (Fine Mesh)	濾過網 (細目)	1
4	304	Oil Wick for 34143	油芯	1
5	34143	Feed Bar Driving Connection Oil Nozzle	オイルパイプ	1
6	3432	Screw for 34143	オイルパイプ止ネジ	1
7	38221	Plug for 3432	埋メ座	1
8	37697	Oil Nozzle Caps	注油キャップ	6
9	34207	Round Oil Filter Holder Pipe	濾過網受ケ	1
10	34110	Upper Looper Bar Oiling Felt	ルーバーフェルト	1
11	530	Washer for 34110	座金	1
12	9142	Screw for 34110	止ネジ	1
13	550	Washer for 34110	座金	1
14	4353	Screw for 34110	止ネジ	1
15	34206	Under Pump Oil Filter Screen	ポンプ濾過網	1
16	34208	Under Pump Oil Filter Screen Clamp	ポンプ濾過網押工	1
17	1175	Screws for 34208	ポンプ濾過網押工	3
18	34441	Oil Pump Complete Set	ポンプ (組)	1
19	30711	Oil Pump Driving Worm Gear	ウォームギヤ	1
20	1459	Screws for 30711	ウォームギヤ 止ネジ	2
21	34442	Oil Pump	ポンプ本体	1
22	9106	Screws for 34442	ポンプ本体止ネジ	3
23	9909	Oil Tube Fitting Nuts	管継手ナット	3
24	750	Plug for 34442	埋メ座	1
25	32944	Oil Tube Clamps	緊束環	4
26	5133	Screws for 32944	緊束環止ネジ	4
27	331	Nuts for 32944	緊束環ナット	4
28	34438	Sponge (Large)	スポンジ (大)	1
29	34439	Sponge (Small)	スポンジ (小)	1
30	34447	Sponge Holder	スポンジ押工	1
31	4358	Screws for 34447	スポンジ押工止ネジ	2
32	32417	Oil Sight Gauge	オイルゲージ	1
33	34201	Oil Tubes	ビニールパイプ	2
34	34203	Top Oiler Bracket	ノズル支工	1
35	4440	Screw for 34203	ノズル支工止ネジ	1
36	34204	Top Oiler	給油管	1
37	570	Washers for 34204	座金	2
38	34202	Oil Sight Top Nozzle	ノズル	1
39	34269	Silicone Oil Supplying Unit	S P 装置 (組)	1

10

DCZ-401

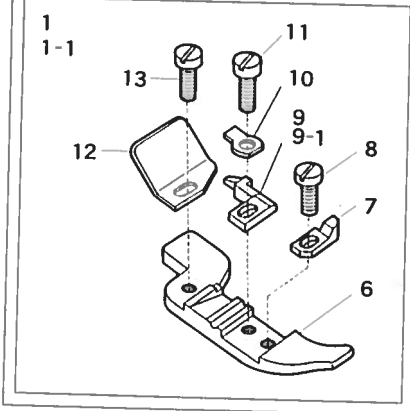

DCZ-403

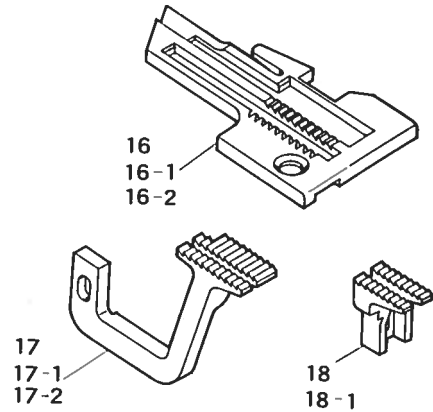
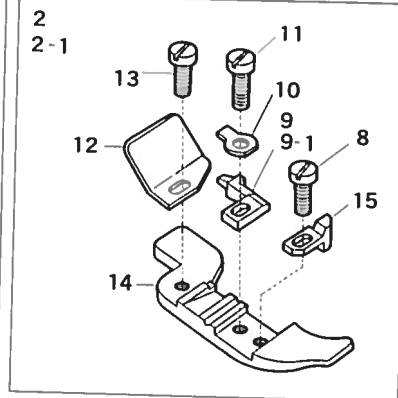

DCZ-406

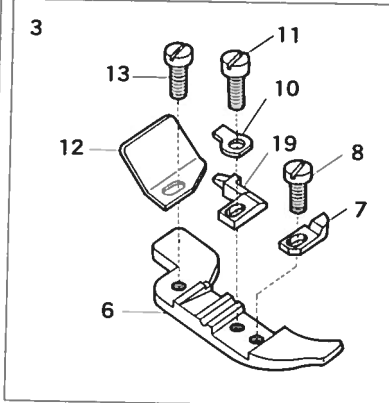

DCZ-410

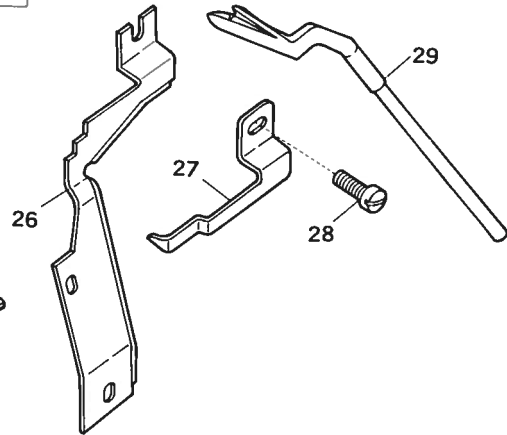
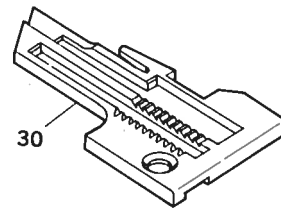
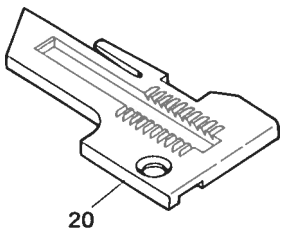
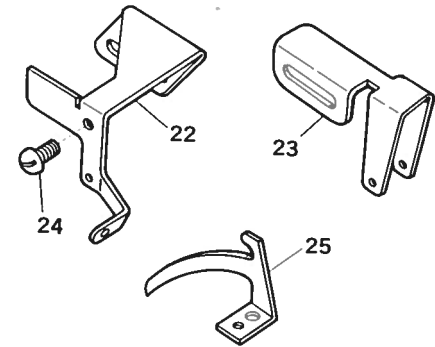
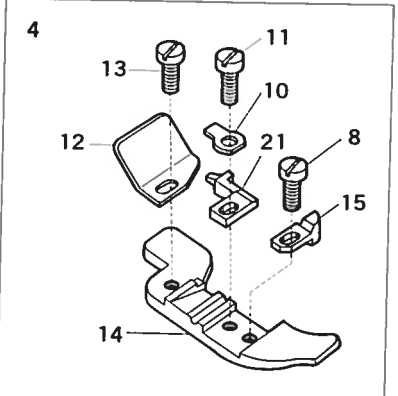

DCZ-445

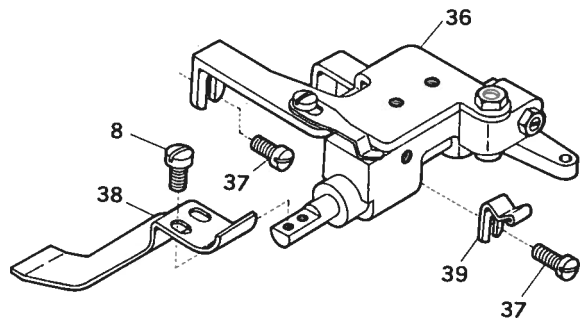
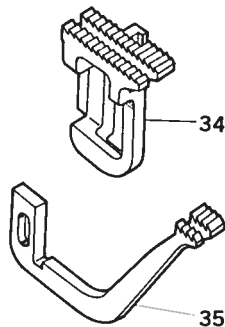
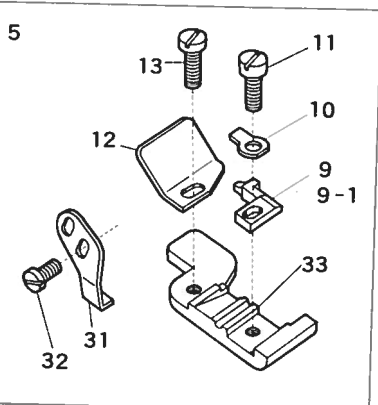

Ref. No.	Parts No.	Description	品名	Amt. Req.
1	34081	Presser Foot Complete Set #1 for DCZ-401	押工 (組) (DCZ-401 #1)	1
1-1	34082	Presser Foot Complete Set #2, #3 for DCZ-401	押工 (組) (DCZ-401 #2, #3)	1
2	34083	Presser Foot Complete Set #1 for DCZ-403	押工 (組) (DCZ-403 #1)	1
2-1	34084	Presser Foot Complete Set #2, #3 for DCZ-403	押工 (組) (DCZ-403 #2, #3)	1
3	34087	Presser Foot Complete Set for DCZ-406	押工 (組) (DCZ-406)	1
4	34066	Presser Foot Complete Set for DCZ-410	押工 (組) (DCZ-410)	1
5	34463	Presser Foot Complete Set #1 for DCZ-445	押工 (組) (DCZ-445 #1)	1
5-1	34464	Presser Foot Complete Set #2, #3 for DCZ-445	押工 (組) (DCZ-445 #2, #3)	1
6	32740	Presser Foot	押工 (下)	1
7	32745	Presser Foot Chip Guard	押エチップ	1
8	1230	Screw for 32745, 32710, 33355	止ネジ	1
9	32744	Presser Foot Stitch Tongue #1	爪 #1	1
9-1	32943	Presser Foot Stitch Tongue #2, #3	爪 #2 #3	1
10	30619	Presser Foot Hinge Spring	押エヒンジバネ	1
11	5036	Screw for 30619	押エヒンジバネ止ネジ	1
12	34535	Presser Foot Chaining Shield	空糸押工	1
13	1228	Screw for 34535	空糸押工止ネジ	1
14	32708	Presser Foot	押工 (下)	1
15	32710	Presser Foot Chip Guard	押エチップ	1
16	32671	Throat Plate #1 for DCZ-403	針板 #1	1
16-1	32672	Throat Plate #2 for DCZ-403	針板 #2	1
16-2	32673	Throat Plate #3 for DCZ-403	針板 #3	1
17	33813	Differential Feed Dog (Standard)	前送り (標準)	1
17-1	33816	Differential Feed Dog (Coarse Mesh)	前送り (並目)	1
17-2	33817	Differential Feed Dog (Large Teeth)	前送り (荒歯)	1
18	33814	Main Feed Dog (Standard)	後送り (標準)	1
18-1	33818	Main Feed Dog (Large Teeth)	後送り (荒歯)	1
19	32732	Presser Foot Stitch Tongue	爪	1
20	32669	Throat Plate for DCZ-406	針板	1
21	34063	Presser Foot Stitch Tongue	爪	1
22	34365	Needle Thread Eyelet (Large)	針糸道	1
23	34366	Needle Thread Eyelet (Small)	針糸道 (小)	1
24	1330	Screw for 34366	針糸道 (小) 止ネジ	1
25	34367	Needle Thread Pull-Off	針糸繰り	1
26	34061	Chip Guard (Fix)	切屑落シ板	1
27	34064	Ajusting Stitch Tongue	補助爪	1
28	1326	Screw for 34064	補助爪止ネジ	1
29	34120	Spreader	スプレザー	1
30	34062	Throat Plate for DCZ-410	針板	1
31	34460	Presser Foot Stay	押工固定片	1
32	4404	Screws for 34460	押工固定片止ネジ	2
33	33342	Presser Foot	押工 (下)	1
34	33344	Main Feed Dog	後送り	1
35	33343	Differential Feed Dog	前送り	1
36	34462	Presser Plate Assembly	ギャザ取り装置 (組)	1
37	7405	Screws for 34462, 33400	止ネジ	2
38	33355	Presser Plate	ギャザ取り押工	1
39	33400	Front Cover Latch Spring	前開キカバーバネ	1

DCZ-400K

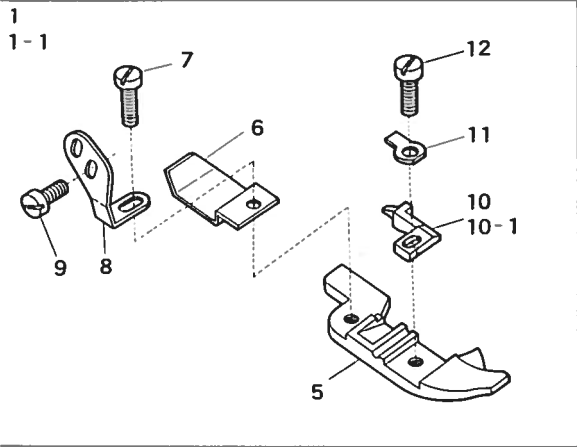

DCZ-401K

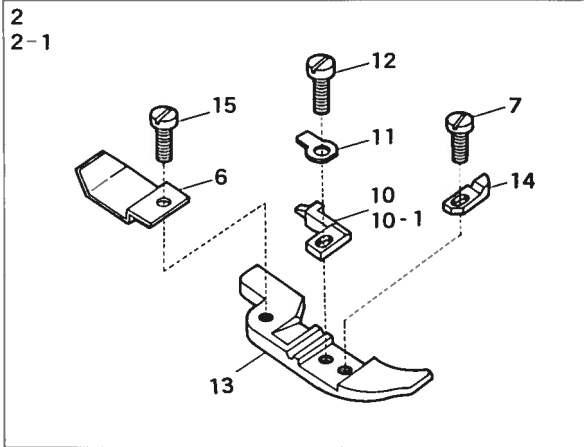

DCZ-403K

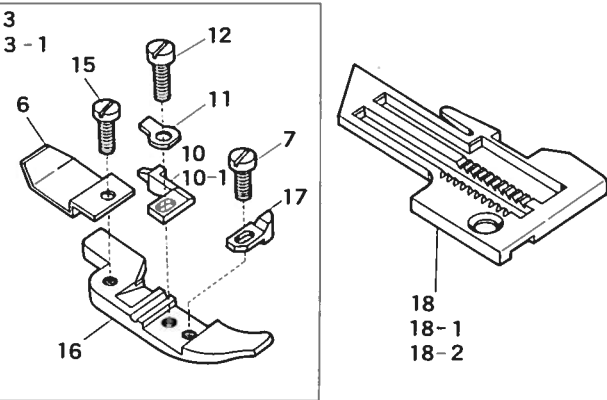

DCZ-414K

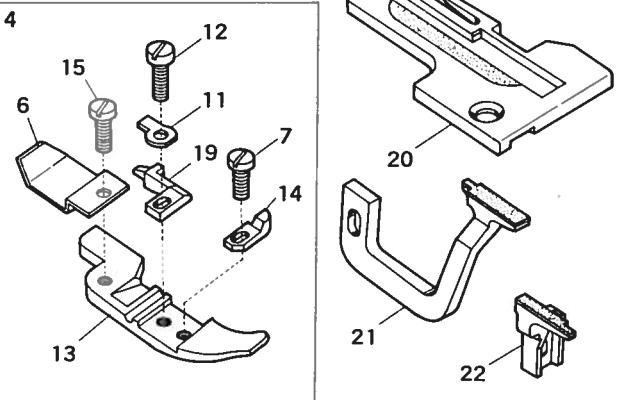

"K"DEVICE

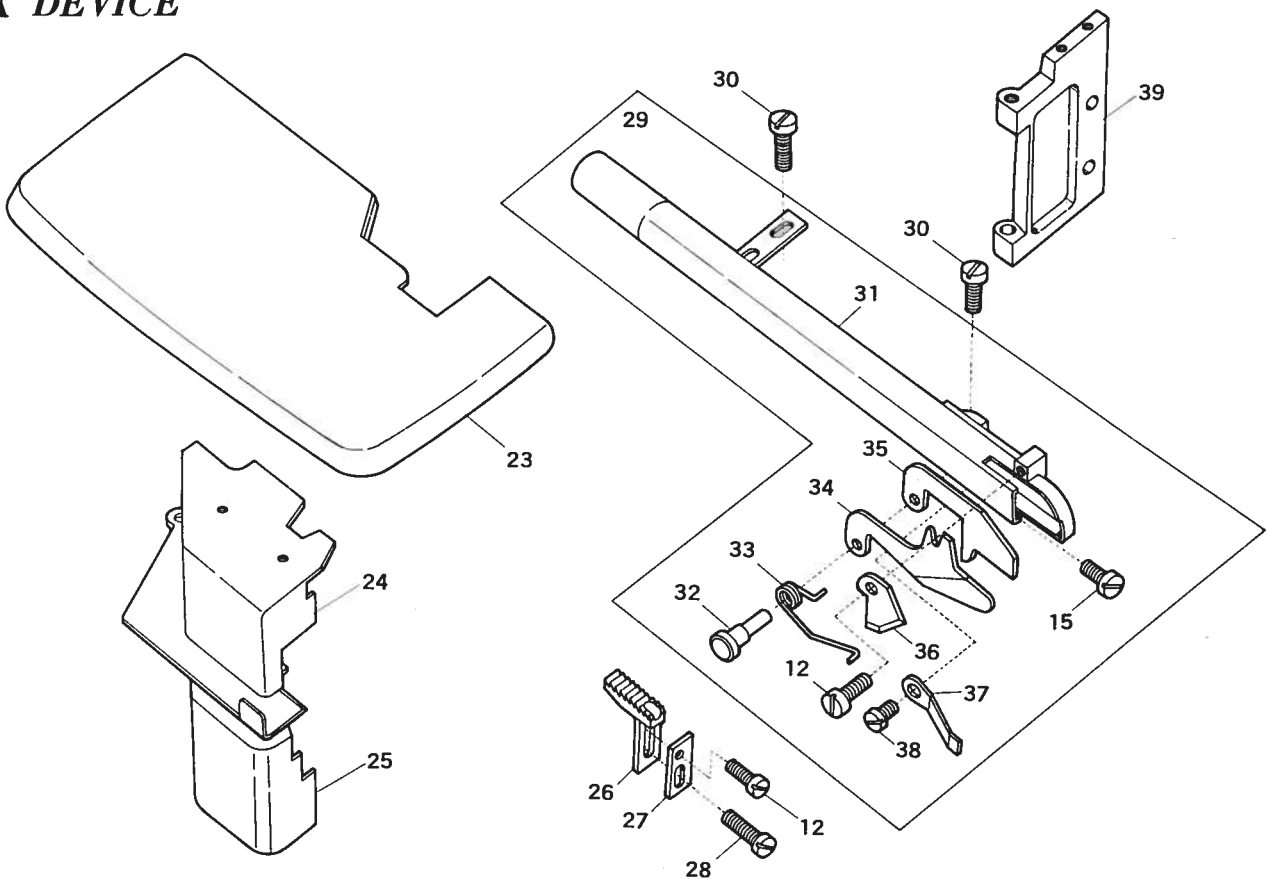

Ref. No.	Parts No.	Description	品名	Amt. Req.
1	33487	Presser Foot Complete Set #1 for DCZ-400K	押工 (組) (DCZ-400K #1)	1
1-1	33488	Presser Foot Complete Set #2, #3 for DCZ-400K	押工 (組) (DCZ-400K #2, #3)	1
2	33489	Presser Foot Complete Set #1 for DCZ-401K	押工 (組) (DCZ-401K #1)	1
2-1	33490	Presser Foot Complete Set #2, #3 for DCZ-401K	押工 (組) (DCZ-401K #2, #3)	1
3	33491	Presser Foot Complete Set #1 for DCZ-403K	押工 (組) (DCZ-403K #1)	1
3-1	33492	Presser Foot Complete Set #2, #3 for DCZ-403K	押工 (組) (DCZ-403K #2, #3)	1
4	34363	Presser Foot Complete Set for DCZ-414K	押工 (組) (DCZ-414K)	1
5	33468	Presser Foot	押工 (下)	1
6	33471	Presser Foot Chain Shield	空糸押工	1
7	1230	Screw for 33471, 32745, 32710	止ネジ	2
8	34292	Presser Foot Stay	押工固定片	1
9	4404	Screws for 34292	押工固定片止ネジ	2
10	32744	Presser Foot Stitch Tongue #1	爪 #1	1
10-1	32743	Presser Foot Stitch Tongue #2, #3	爪 #2 #3	1
11	30619	Presser Foot Hinge Spring	押工ヒンジバネ	1
12	5036	Screw for 30619, 33461, 33912	止ネジ	3
13	33469	Presser Foot	押工 (下)	1
14	32745	Presser Foot Chip Guard	押工チップ	1
15	1228	Screw for 32741	空糸押工止ネジ	1
16	33470	Presser Foot	押工 (下)	1
17	32710	Presser Foot Chip Guard	押工チップ	1
18	33465	Throat Plate #1	針板 #1	1
18-1	33466	Throat Plate #2	針板 #2	1
18-2	33467	Throat Plate #3	針板 #3	1
19	34362	Presser Foot Stitch Tongue	爪	1
20	34359	Throat Plate	針板	1
21	34371	Differential Feed Dog	前送り	1
22	34372	Main Feed Dog	後送り	1
23	33473	Cloth Plate (Upper)	大カバー	1
24	33475	Feed Mechanism Cover	送りリンクカバー	1
25	33476	Feed Mechanism Oil Shield	送りリンクカバー (小)	1
26	33461	Auxiliary Feed Dog	小送り	1
27	33460	Trimming Knife (Lower) Guide	下刃ガイド	1
28	7609	Screw for 33460	下刃ガイド止ネジ	1
29	33913	Suction Pipe Complete Set	吸込管 (組)	1
30	4353	Screws for 33913	吸込管 (組) 止ネジ	3
31	33915	Suction Pipe	吸込管	1
32	33459	Trimming Knife Holder Pin	刃支持ピン	1
33	33458	Trimming Knife Spring	下刃バネ	1
34	33456	Trimming Knife (Upper)	上刃	1
35	33907	Trimming Knife (Lower)	下刃	1
36	33912	Trimming Knife (Upper) Guide	上刃ガイド	1
37	33911	Trimming Knife Reinforced Spring	下刃圧差バネ	1
38	4237	Screw for 33911	下刃圧差バネ止ネジ	1
39	33474	Cloth Plate Hinge	横カバーヒンジ	1

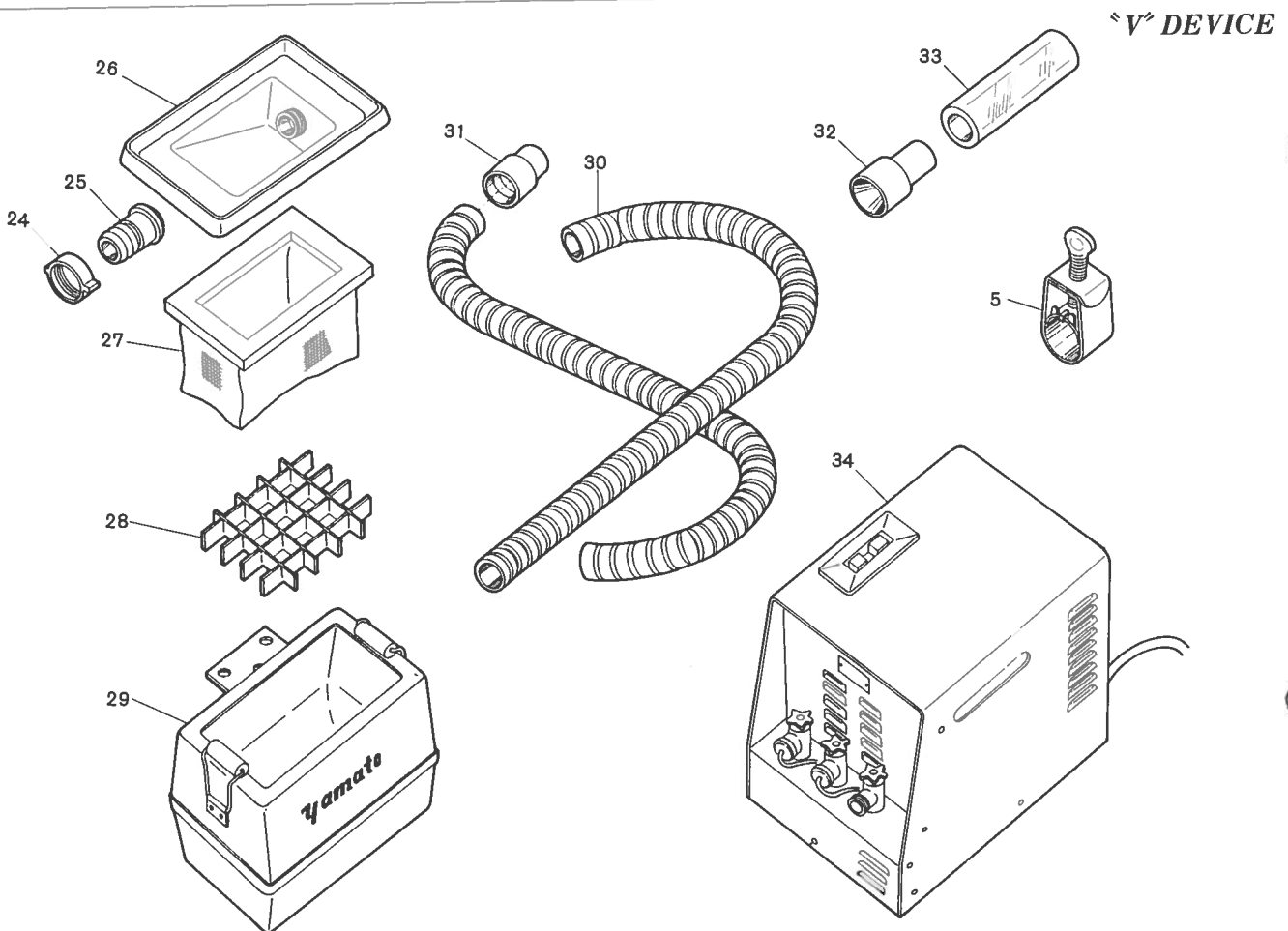
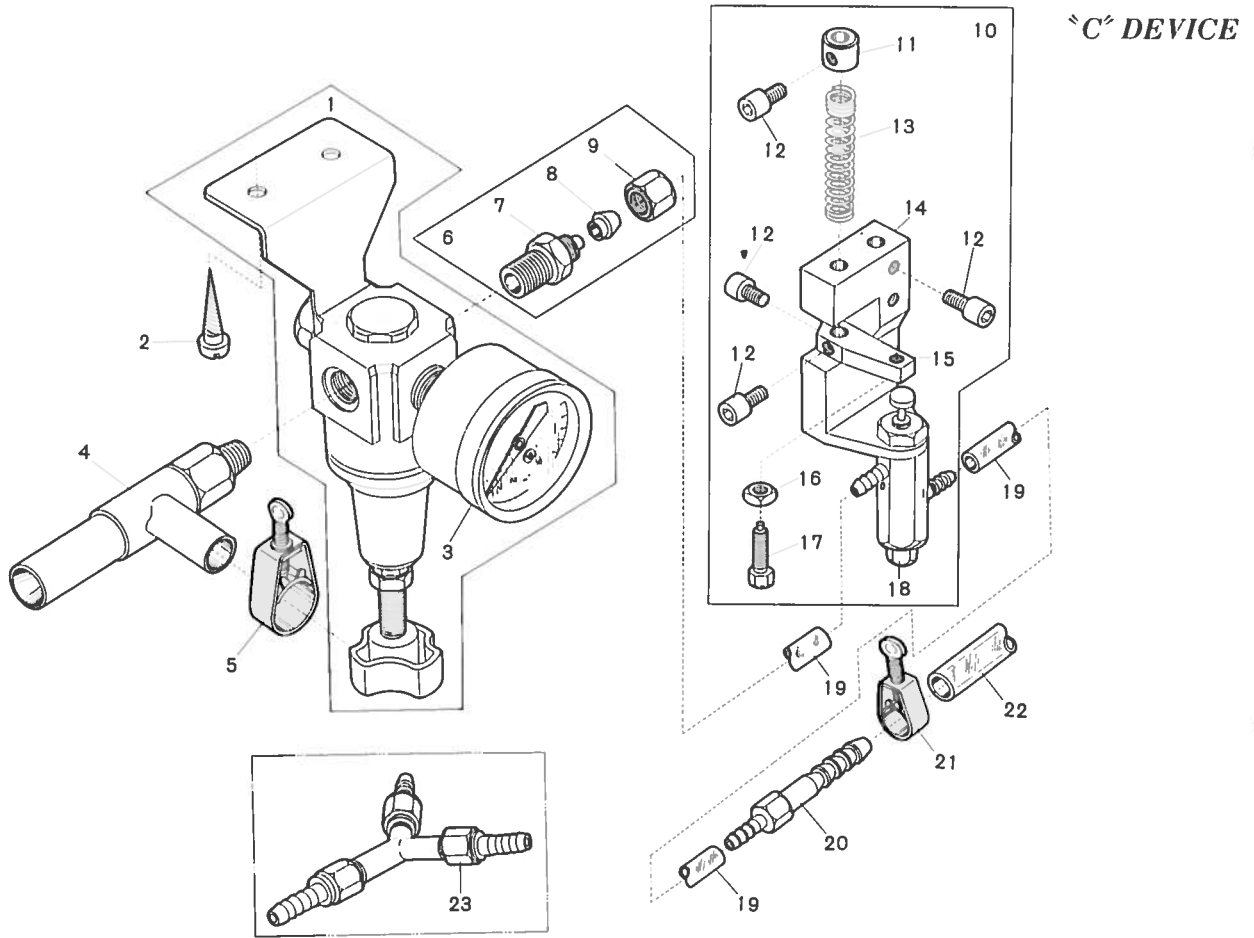

Ref. No.	Parts No.	Description	品名	Amt. Req.
1	33925	Regulator Complete Set	レギュレーター (組)	1
2	6905	Screws for	レギュレーター取付ネジ	2
3	33928	Pressure Gauge	プレッシャーゲージ	1
4	33930	Venturi Tube Complete Set	ベンチュリー管 (組)	1
5	33940	Hose Band 3/8"	3/8"ホースバンド	1
6	33931	Mouth-Piece Charge 1/8" Complete Set	1/8"ストレートジョイント (組)	1
7	33949	Mouth-Piece Charge 1/8"	1/8"ストレートジョイント	1
8	33951	Pipe Holder	ナイロンホルダー	1
9	33950	Nut for Straight Joint	ナット	1
10	33953	Air Valve Complete Set	エヤバルブ (組)	1
11	33938	Collar for Air Valve Spring	エヤバルブ補助バネカラー	1
12	5040	Screws for 33938, 33935, 33936	止ネジ	6
13	33937	Return Spring for Air Valve Stopper	エヤバルブ補助バネ	1
14	33936	Holder for Air Valve	エヤバルブ取付台	1
15	33935	Air Valve Stopper	エヤバルブストッパー	1
16	334	Nut for 33935	ナット	1
17	5505	Screw for 33935	エヤバルブストッパー調節ネジ	1
18	33934	Air Valve	エヤバルブ	1
19	33941	Nylon Hose	ナイロンホース	1
20	33932	Joint for Used A Single Head	ジョイント (ミシンが2台の時のみ使用)	1
21	33939	Hose Bands 1/4"	1/4"ホースバンド	3
22	33942	Nylon Hose	ナイロンホース	1
23	33933	Three Pronged Joint for Used Plural Heads	三又ジョイント (ミシンが2台以上の時使用)	1
24	33505	Hose Pipe Bases (Upper)	ホース口金 (上)	2
25	33506	Hose Pipe Bases (Lower)	ホース口金 (下)	2
26	33507	Trimmed Thread Collector Cap	コレクター蓋	1
27	33508	Trimmed Thread Collector Net	集塵袋	1
28	33509	Trimmed Thread Collector Net Holder	集塵袋支工	1
29	33495	Trimmed Thread Collector Complete Set	コレクター本体	1
30	33504	Hoses	ホース	2
31	33503	Hose Joints	ホースジョイント	3
32	33926	Middle Joint for Hose Pipe	ジョイント	2
33	33952	Nylon Hose	ナイロンホース	1
34	33486	YV-100 (Suction Pump)	吸引ポンプ (YV-100)	1

Note		注記	
Please note that the following devices have been explained.		下記装置の説明を参照下さい。	
“K” Device	Automatic Chain-thread Cutter	“K” 装置	自動カラ環切り装置
“C” Device	With this unit the thread chain trimmed with “K” chain-thread Cutter is blown into a Suction Pipe automatically by means of Air Compressor system. (A Compressor is available at extra charge.)	“C” 装置	この装置は自動カラ環切り装置で切断されたカラ環をエア・コンプレッサーによって自動的に吸込管に吸込む装置です。(コンプレッサーは必要に応じて特別注文で御利用下さい。)
“V” Device	With this unit the thread chain trimmed with “K” chain-thread Cutter is blown into a Pipe by means of Vacuum Pump system. (A Vacuum Pump is available at extra charge on request.)	“V” 装置	この装置は自動カラ環切り装置で切断されたカラ環を吸込ポンプによって自動的に吸込管に吸込む装置です。(吸引ポンプは必要に応じて特別注文で御利用下さい。)
“KC” Device	This is complete set consisting of “K” chain-thread Cutter and “C” Device of Air Compressor system.	“KC” 装置	この装置は“K”装置と“C”装置を併用しています。
“KV” Device	This is complete set consisting of “K” chain-thread Cutter and “V” Device of Vacuum Pump system.	“KV” 装置	この装置は“K”装置と“V”装置を併用しています。

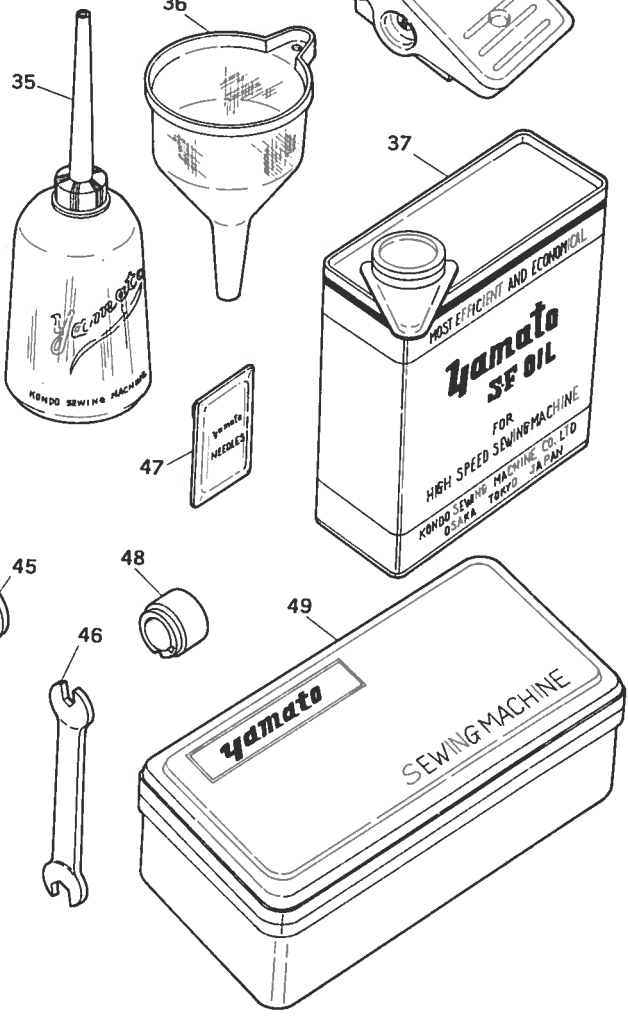
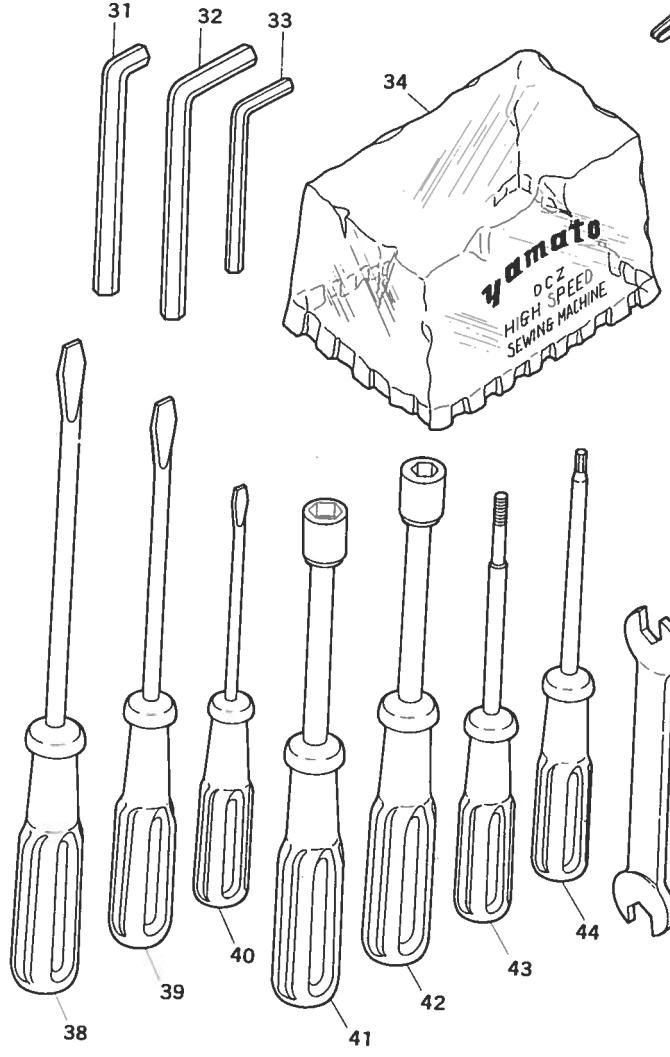
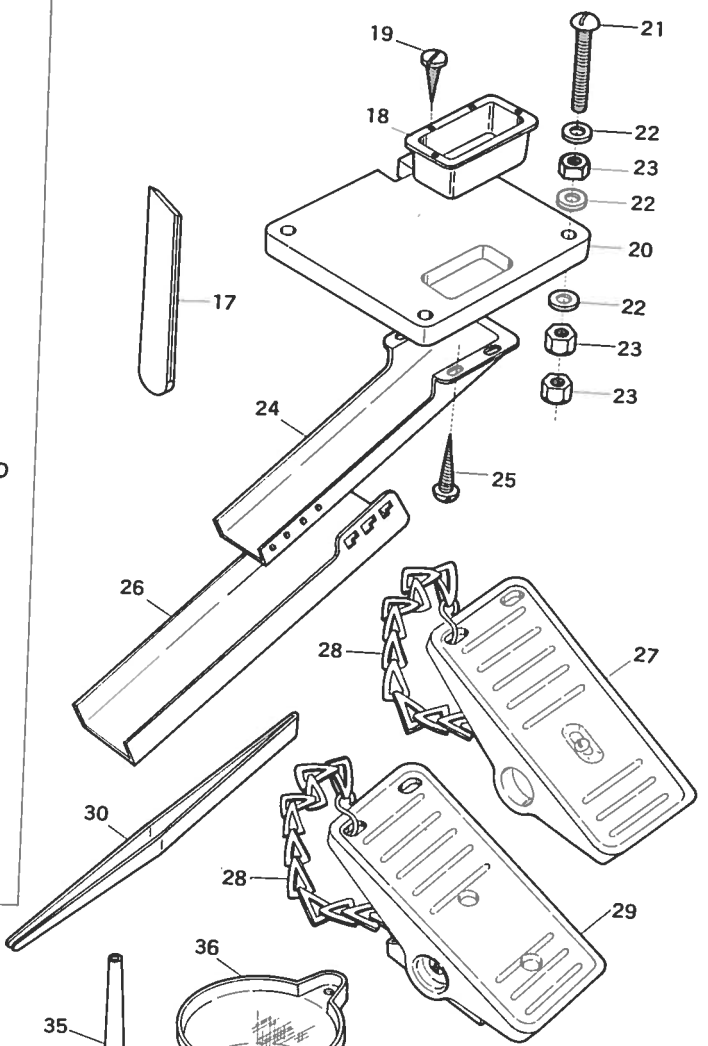
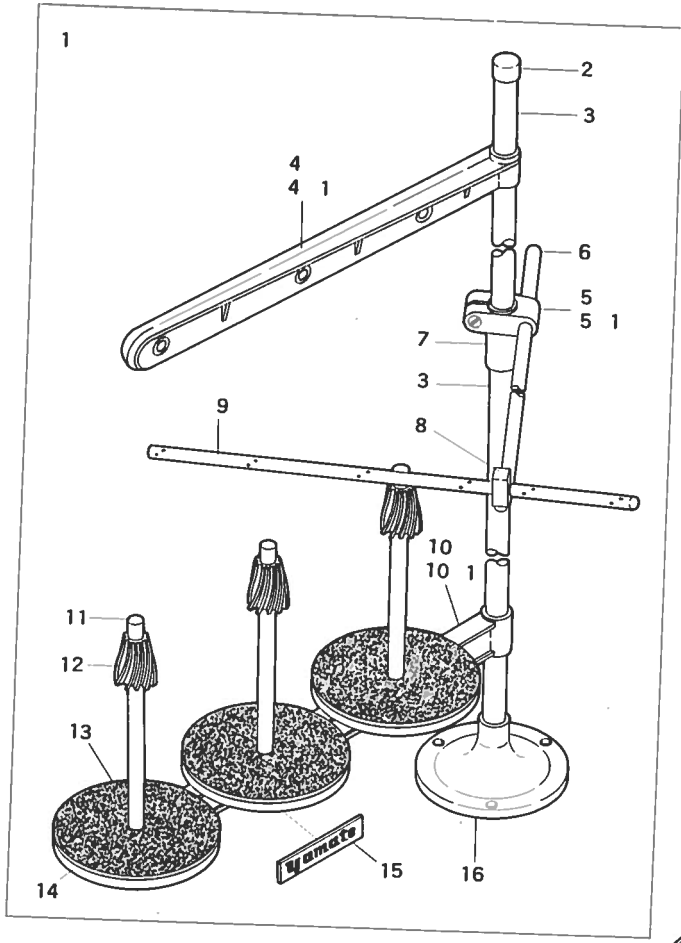

Ref. No.	Parts No.	Description	品名	Amt. Req. Exp't. 国内
1	99001	Thread Stand 3 Spool Type Complete Set	3本糸用糸立 (組)	1 . 1
2	99013	Culm Cap	コラムキャップ	1 . 1
3	99011	Culm Pipe	コラムパイプ	1 . 1
4	99026	Thread Hanger (3 Spool Type) Complete Set	スレッドハンガー (3本糸用) (組)	1 . 1
4-1	99027	Thread Hanger (3 Spool Type)	スレッドハンガー (3本糸用)	1 . 1
5	99028	Thread Guide Holder Complete Set	糸案内ホルダー (組)	1 . 1
5-1	99029	Thread Guide Holder	糸案内ホルダー	1 . 1
6	99030	Thread Guide Bar	糸案内支工棒	1 . 1
7	99012	Culm Socket	コラムソケット	1 . 1
8	99031	Thread Guide Bar Bracket	支工棒接点	1 . 1
9	99032	Thread Guide	糸案内	1 . 1
10	99024	Spool Holder (3 Spool Type) Complete Set	スプールホルダー (3本糸用) (組)	1 . 1
10-1	99025	Spool Holder (3 Spool Type)	スプールホルダー (3本糸用)	1 . 1
11	99017	Spool Pins	スプール軸	3 . 3
12	99020	Spool Cushions	スプールのクッション	3 . 3
13	99018	Spool Mats	スプールのマット	3 . 3
14	99019	Spool Seat Disc	受け皿	3 . 3
15	99016	Name Plate	ネームプレート	1 . 1
16	99010	Thread Stand Base	糸立台	1 . 1
17	30421	Lower Knife	下メス	1 . 1
18	30080	Window of Chute	トコ受け	1 . 1
19	—	Wood Screws	木ネジ	4 . 4
20	30083	Supporting Board	受板	1 . 1
21	—	Bolts for Supporting Board	受板吊りボルト	4 . 4
22	—	Washers	座金	4 . 4
23	—	Nuts	ナット	4 . 4
24	30081	Chute (Upper)	トユ (上)	1 . 1
25	—	Wood Screws	木ネジ	4 . 4
26	30082	Chute (Lower)	トユ (下)	1 . 1
27	37911	Pedal Complete Set	ペダル (組)	1 . 1
28	37912	Chain	鎖	1 . 1
29	37907	Pedal Complete Set	ペダル (組)	1 . 1
30	37909	Thread Tweezers	ピンセット	1 . 1
31	37921	Hexagon Wrench Key	キーレンチ	1 . 1
32	37922	Hexagon Wrench Key	キーレンチ	1 . 1
33	37916	Hexagon Wrench Key	キーレンチ	1 . 1
34	37939	Machine Cover	ビニールカバー	1 . 1
35	37932	Oiler	油差シ	1 . 1
36	37943	Funnel	ショウゴ	1 . 1
37	—	Oil	オイル	1 . 1
38	37901	Screw Driver (Large)	ドライバー (大)	1 . 1
39	37902	Screw Driver (Medium)	ドライバー (中)	1 . 1
40	37903	Screw Driver (Small)	ドライバー (小)	1 . 1
41	37946	Socket Wrench (9.52mm)	ソケットレンチ (9.52mm)	1 . 1
42	37918	Socket Wrench	ソケットレンチ	1 . 1
43	37947	Feed Driving Eccentric Extactor	送りエキセン抜き	1 . 1
44	37923	Hexagon Screw Driver (1.98mm)	六角レンチ付ドライバー (1.98mm)	1 . 1
45	37945	Wrench (Large) (7.14mm×7.94mm)	両口スパナ (7.14mm×7.94mm)	1 . 1
46	37915	Wrench (Small) (7.14mm×7.14mm)	両口スパナ (7.14mm×7.14mm)	1 . 1
47	—	Needles (GAS 154)	針	10 . 10
48	—	Feed Driving Eccentric	送り前後エキセン	3 . 2
49	37913	Attachment Box	付属品箱	1 . 1

INDEX

Parts No.	Page No.	Ref. No.	Parts No.	Page No.	Ref. No.	Parts No.	Page No.	Ref. No.	Parts No.	Page No.	Ref. No.
10	3	8	1448	2	29	5074	5	44	9853	3	4
20	8	24	1448	4	35	5076	1	45	9909	9	23
282	6	25	1457	4	26	5077	2	3	01111	2	12
286	2	13	1459	2	34	5089	1	7	30080	13	18
291	8	15	1459	7	18	5095	1	19	30081	13	24
304	6	31	1459	9	20	5131	1	29	30082	13	26
304	9	4	1892	7	13	5133	9	26	30083	13	20
331	9	27	2043	6	8	5401	5	35	30126	1	17
334	1	14	3311	6	26	5500	6	23	30228	5	1
334	12	16	3404	6	10	5505	7	32	30228	6	49
340	5	54	3432	9	6	5505	12	17	30254	2	16
340	6	5	3433	2	8	5508	5	32	30291	4	30
340	7	31	3433	4	9	5520	5	5	30421	5	45
355	5	11	3434	1	47	5522	5	24	30421	13	17
451	8	17	3436	4	7	5550	5	9	30619	7	4
461	2	19	3632	8	2	5550	6	15	30619	10	10
518	4	37	3635	6	12	5550	7	22	30619	11	11
520	5	4	3635	8	3	6000	7	28	30711	9	19
520	6	22	3638	6	42	6004	2	32	32375	1	36
529	2	4	4237	11	38	6004	3	9	32377	1	38
530	9	11	4351	3	13	6007	6	19	32417	9	32
532	3	20	4353	2	22	6040	1	18	32421	1	44
550	9	13	4353	3	6	6262	1	39	32519	2	25
563	1	37	4353	5	47	6403	2	20	32586	1	13
567	1	42	4353	8	30	6405	2	37	32604	1	16
570	9	37	4353	9	14	6542	2	11	32604	5	40
605	8	23	4353	11	30	6662	5	39	32609	1	40
606	6	18	4358	1	41	6905	12	2	32610	1	23
698	5	50	4358	2	40	6910	1	11	32611	1	28
722	8	8	4358	5	19	7302	6	33	32612	1	46
723	5	28	4358	6	29	7405	10	37	32646	5	20
726	1	5	4358	9	31	7605	1	9	32666	5	34
726	2	6	4402	4	23	7609	8	33	32667	5	34-1
727	1	31	4404	7	10	7609	11	28	32669	10	20
750	9	24	4404	10	32	7616	5	27	32671	10	16
839	1	48	4404	11	9	7650	4	11	32672	10	16-1
977	1	4	4437	5	52	7650	5	37	32673	10	16-2
1175	2	24	4440	1	24	7650	6	35	32682	5	34-2
1175	9	17	4440	5	49	8163	5	25	32684	4	31
1222	1	27	4440	8	24	9106	9	22	32708	10	14
1228	3	11	4440	9	35	9127	7	30	32710	10	15
1228	10	13	4441	4	20	9142	6	39	32710	11	17
1228	11	15	4591	5	42	9142	9	12	32711	7	27
1230	7	7	5000	8	28	9150	1	3	32715	7	26
1230	10	8	5002	2	5	9150	3	15	32716	7	29
1230	11	6	5003	2	2	9200	2	27	32732	10	19
1326	1	27	5004	6	37	9200	7	16	32736	7	2
1326	3	14	5006	4	24	9200	8	5	32740	10	6
1326	6	48	5036	7	5	9202	4	22	32743	7	3-1
1326	10	28	5036	10	11	9209	2	9	32743	10	10-1
1330	1	25	5036	11	12	9209	4	3	32744	7	3
1330	3	21	5040	12	12	9604	5	2	32744	10	9
1330	10	24	5043	5	53	9604	6	50	32744	11	10
1333	2	43	5070	5	16	9730	8	35	32745	10	7
1435	4	13	5070	6	2	9851	1	43	32745	11	14

INDEX

14

Parts No.	Page No.	Ref. No.	Parts No.	Page No.	Ref. No.	Parts No.	Page No.	Ref. No.	Parts No.	Page No.	Ref. No.
32775	4	16	33460	11	27	33941	12	19	34097	6	13
32777	4	17	33461	11	26	33942	12	22	34098	4	38
32778	4	15	33465	11	18	33949	12	7	34099	6	11
32779	4	14	33466	11	18-1	33950	12	9	34100	6	7
32786	6	9	33467	11	18-2	33951	12	8	34101	6	46
32789	6	40	33468	11	5	33952	12	33	34102	6	6
32792	6	14	33469	11	13	33953	12	10	34103	6	4
32817	4	19	33470	11	16	34000	3	1	34104	6	21
32818	4	18	33471	11	6	34002	2	38	34105	6	27
32819	5	17	33473	11	23	34003	1	12	34110	9	10
32819	6	47	33474	11	39	34007	1	30	34111	6	48
32848	6	16	33475	11	24	34008	1	32	34113	6	32
32849	6	17	33476	11	25	34011	1	22	34114	4	33
32853	8	16	33486	12	34	34012	1	21	34115	4	8
32864	8	7	33487	11	1	34013	2	47	34116	4	32
32866	8	14	33488	11	1-1	34014	1	34	34117	4	1
32867	8	12	33489	11	2	34015	2	39	34118	6	45
32883	8	34	33490	11	2-1	34016	2	44	34120	10	29
32898	9	1	33491	11	3	34017	3	7	34121	4	34
32899	5	48	33492	11	3-1	34018	1	20	34122	6	24
32902	5	21	33495	12	29	34019	3	14	34130	8	13
32903	5	22	33503	12	31	34020	8	29	34131	8	6
32911	5	29	33504	12	30	34021	1	10	34132	8	22
32912	5	26	33505	12	24	34025	5	38	34133	8	18
32913	5	31	33506	12	25	34026	3	2	34134	8	1
32914	5	30	33507	12	26	34039	1	33	34135	8	4
32916	5	41	33508	12	27	34040	2	1	34136	8	25
32917	5	46	33509	12	28	34045	3	10	34137	8	21
32919	5	43	33510	8	31-1	34050	5	15	34138	8	11
32924	2	41	33511	8	32	34051	5	14	34139	8	9
32925	4	10	33512	8	31	34052	5	3	34141	8	19
32930	2	42	33813	10	17	34053	5	6	34142	8	10
32933	9	2	33814	10	18	34054	4	28	34143	9	5
32943	10	9-1	33816	10	17-1	34055	5	8	34190	5	33
32944	9	25	33817	10	17-2	34056	5	10	34192	4	25
32952	2	45	33818	10	18-1	34057	5	51	34193	4	27
32955	3	22	33907	11	35	34058	5	36	34194	5	23
32958	3	19	33911	11	37	34059	8	27	34195	4	5
32960	3	18	33912	11	36	34060	5	13	34196	6	1
32962	2	10	33913	11	29	34061	10	26	34197	6	3
32965	2	17	33915	11	31	34062	10	30	34201	9	33
32971	2	15	33925	12	1	34063	10	21	34202	9	38
32976	1	1	33926	12	32	34064	10	27	34203	9	34
32977	1	2	33928	12	3	34066	10	4	34204	9	36
33070	4	29	33930	12	4	34079	7	1	34205	3	3
33077	4	12	33931	12	6	34080	7	1-1	34206	9	15
33142	2	26	33932	12	20	34081	10	1	34207	9	9
33342	10	33	33933	12	23	34082	10	1-1	34208	9	16
33343	10	35	33934	12	18	34083	10	2	34217	6	30
33344	10	34	33935	12	15	34084	10	2-1	34218	2	46
33355	10	38	33936	12	14	34087	10	3	34219	2	21
33400	10	39	33937	12	13	34091	4	6	34220	2	7
33456	11	34	33938	12	11	34092	4	2	34222	2	23
33458	11	33	33939	12	21	34094	4	21	34223	5	18
33459	11	32	33940	12	5	34096	4	4	34225	3	23

