

### A 机壳部件/Machine Body & Thread Tension Adjusting Mechanism

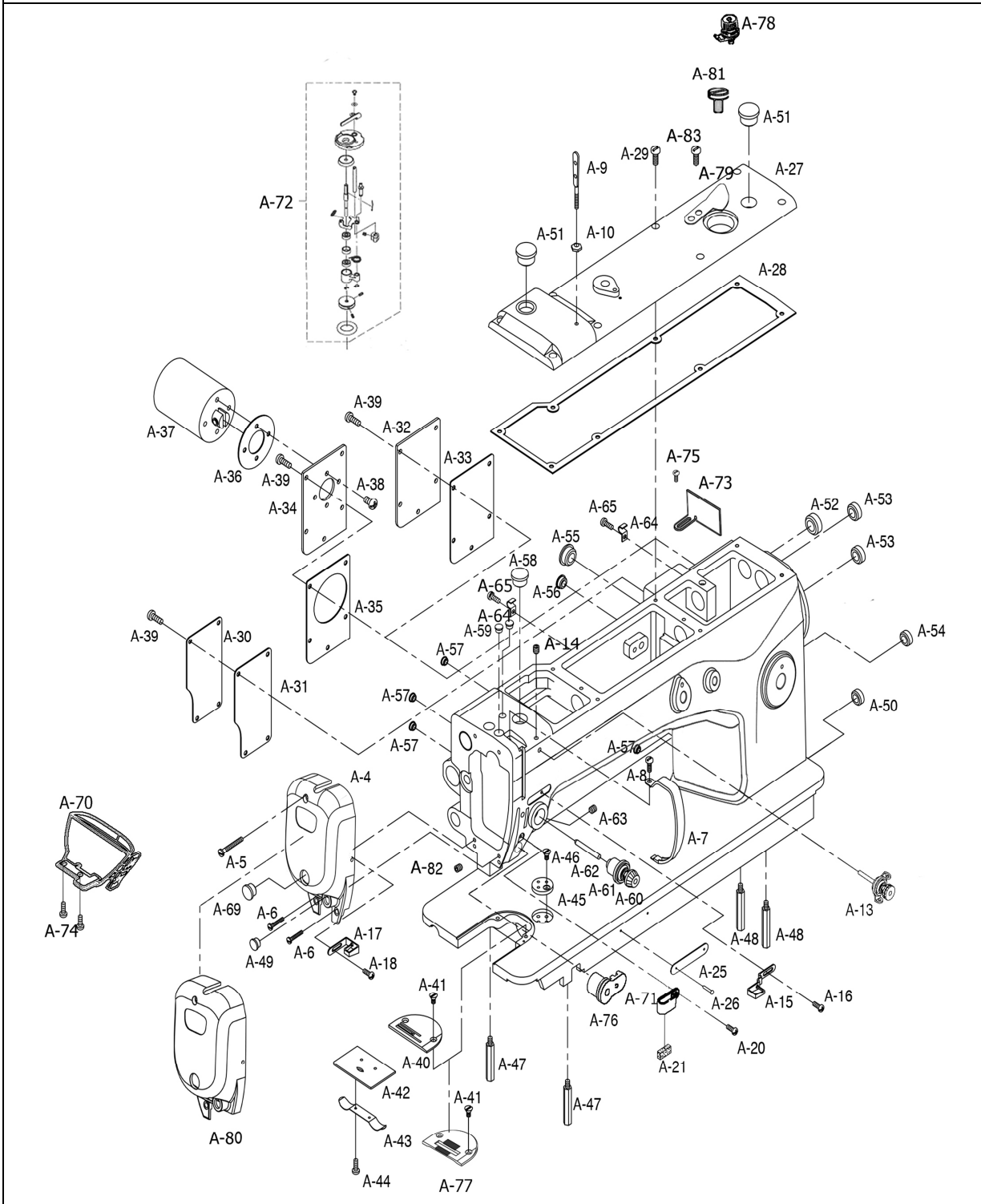

A 机壳部件/Machine Body & Thread Tension Adjusting Mechanism							
序号 No	公司件号	名称 PartName	零件描述 Description	数量			
				30-3Q	30-4Q	60-3Q	60-4Q
A-4	14201001	面板	Face Plate	1			
A-5	142S11001	面板上螺钉	Screw For Face Plate(Upper)	1		1	
A-6	135S11047	面板下螺钉	Screw(11/64" n=40)	2		2	
A-7	14212001	挑线杆防护罩	Thread Take Up Cover	1		1	
A-8	401S11031	挑线杆防护罩螺钉	Screw(11/64" n=40)	1		1	
A-9	14213001	针杆上过线	Upper Thread Guide Pin	1		1	
A-10	142S16001	针杆上过线锁紧螺	Nut For A-9	1		1	
A-13	1351300100	小夹线器组件	Sub Upper Thread Tension	1		1	
A-14	135S15001	小夹线器支头螺钉	Screw(11/64" n=40)	1		1	
A-15	14213004	机壳线勾	Arm Thread Guide	1		1	
A-16	101S11005	机壳线勾螺钉	Screw(9/64" n=40)	1		1	
A-17	14213005	面板线勾	Face Plate Thread Guide	1		1	
A-18	101S11005	面板线勾螺钉	Screw(9/64" n=40)	1		1	
A-20	101S11005	线勾螺钉	Screw(9/64" n=40)	1		1	
A-21	14223001	机针过线夹硅油毡	Upper Thread Oil Felt	1		1	
A-23	14237001	机器型号牌	Model Mark	1		1	
A-24	14237002	机器型号牌	Model Mark	1		1	
A-25	14237003	机器机号牌	Machine Number Plate	1		1	
A-26	14226001	机号牌铆钉	Pin For A-25	2		2	
A-27	14201002	上盖	Top Cover	1		1	
A-28	14222001	上盖密封垫	Gasket For Top Cover	1		1	
A-29	201S11020	上盖螺钉	Screw(11/64" n=40)	8		8	
A-30	14212002	后前盖板	Back Cover(A)	1		1	
A-31	14222002	后前盖板密封垫	Gasket For Back Cover(A)	1		1	
A-32	14212003	后盖板	Rear cover Plate	1		1	
A-33	14222003	后盖板密封垫	Rear COVER PLATE Gasket	1		1	
A-34	14212004	电磁铁盖板	B/T Solenoid Bracket	1		1	
A-35	14222004	电磁铁盖板密封垫	Gasket for B/T Solenoid	1		1	
A-36	14212005	电磁铁连接垫板	Gasket for B/T Solenoid	1		1	
A-37	14230001	倒缝电磁铁组件	B/T Solenoid Asm	1		1	
A-38	406S11009	螺钉 11/64×40×8	Screw(11/64" n=40)	4		4	
A-39	402S11003	螺钉 11/64×40×10	Screw(11/64" n=40)	9		9	
A-40	14215001	针板	Needle Plate	1			
A-4	14201001	面板	Face Plate	1			
A-42	14215002	推板	Slide Plate	1		1	
A-43	14227001	推板簧	Slide Plate Spring	1		1	
A-44	101S11019	推板簧螺钉	Screw For A-43	2		2	
A-45	13812111	夹边座	Gauge Plate	1		1	
A-46	101S11002	夹边座螺钉	Screw(11/64" n=40)	2		2	
A-47	142S30002	机头前支撑杆	Bed Base(Front)	2		2	
A-48	142S30003	机头后支撑杆	Bed Base(Rear)	2		2	
A-49	12922001	橡皮塞	Face Plate Rubber Cap	3		4	
A-50	13522008	下轴后端橡皮塞	Bed Rubber Cap	1		1	
A-51	14222007	上盖橡皮塞	Top Cover Rubber Cap	3		3	
A-52	14222008	倒缝架后孔橡皮塞	Feed Regulator Shaft Rubber	1		1	
A-53	14222009	压脚摆动轴后橡皮	Climb Device Adjusting Shaft	2		2	

A 机壳部件/Machine Body & Thread Tension Adjusting Mechanism

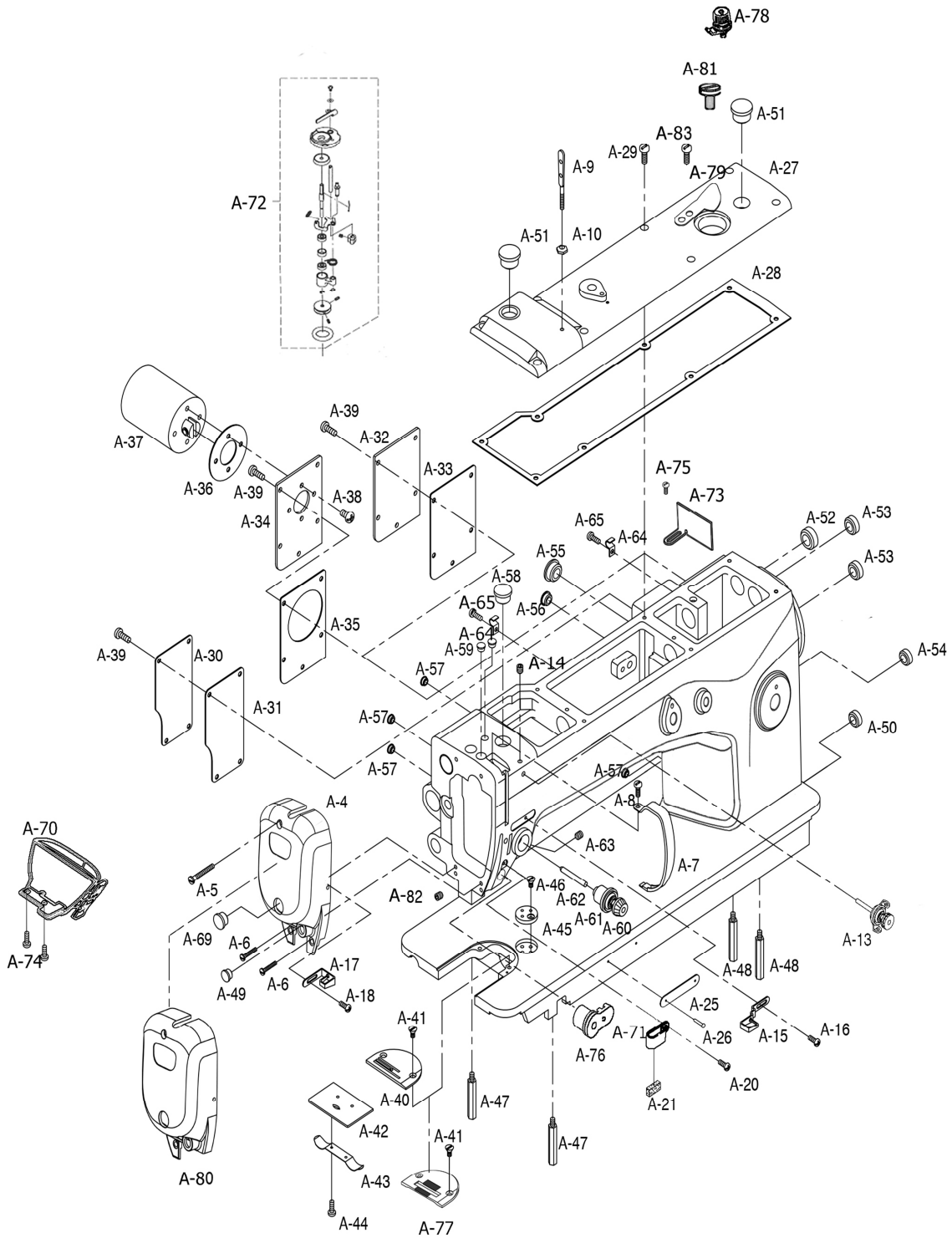

**A 机壳部件/Machine Body & Thread Tension Adjusting Mechanism**

序号 No	公司件号	名称 PartName	零件描述 Description	数量			
				30-3Q	30-4Q	60-3Q	60-4Q
A-54	14222010	倒缝后支点橡皮塞	Feed Adjusting Shaft Rubber	1		1	
A-55	13522008	后大橡皮塞	Arm Back Part Rubber	1		1	
A-56	12922001	橡皮塞	Arm Back Part Rubber	1		1	
A-57	10122005	机壳后左橡皮塞	Arm Back Part Rubber	6		6	
A-58	14222014	倒缝电磁铁电线橡	Arm Upper Part Rubber	1		1	
A-59	10122013	针杆上套橡皮塞	Arm Upper Part Rubber	1			
A-60	11421300100	夹线器组件	Thread Tension Control	1		1	
A-61	14222016	夹线器防油圈	Rubber Cap For A-60	1		1	
A-62	14226002	松线钉	Tension Release Pin	1		1	
A-63	135S11001	夹线器紧固螺钉	Screw(15/64" n=28)	1		1	
A-64	14212007	电线夹	Cable Holder	3		3	
A-65	101S11002	电线夹螺钉	Screw(11/64" n=40)	3		3	
A-66	14212008	侧盖板电线夹	Holder for Upper Thread Oil	1		1	
A-69	14222007	面板橡皮塞	Rubber Cap	1		1	
A-70	1423001000	倒送料开关组件	Reverse Feed Assembly	1		1	
A-71	14213011	下过线勾	Arm Thread Guide Plate(L)	1		1	
A-72	1423102600	绕线器组件	Bobbin Winder Assembly	1		1	
A-73	14212067	挡油板	Keep off Plate	1		1	
A-74	421S13061	开关固定螺钉	Screw (M3)	2		2	
A-75	421S13038	螺钉 M3×6	Screw (M4)	2		2	
A-76	1423001100	电子夹线器	Electronic Thread Clamp	1		1	
A-77	14215003	针板 (三同步)	Needle plate (triple sync)			1	
A-78	4031360100	张力控制组件	Tension control Component	1		1	
A-79	11419001	割线刀	Thread Cutter	1		1	
A-80	14201014	面板 (三同步)	Panel (triple Sync)			1	
A-81	114S11003	绕线器螺钉	Screw	3		3	
A-82	S10008	内六角支头螺钉	Screw (M4)	1		1	
A-83	114S11015	螺钉	Screw (9/64"×40)	2		2	

# B 上轴针杆部件/Upper Shaft & Needle Bar Mechanism

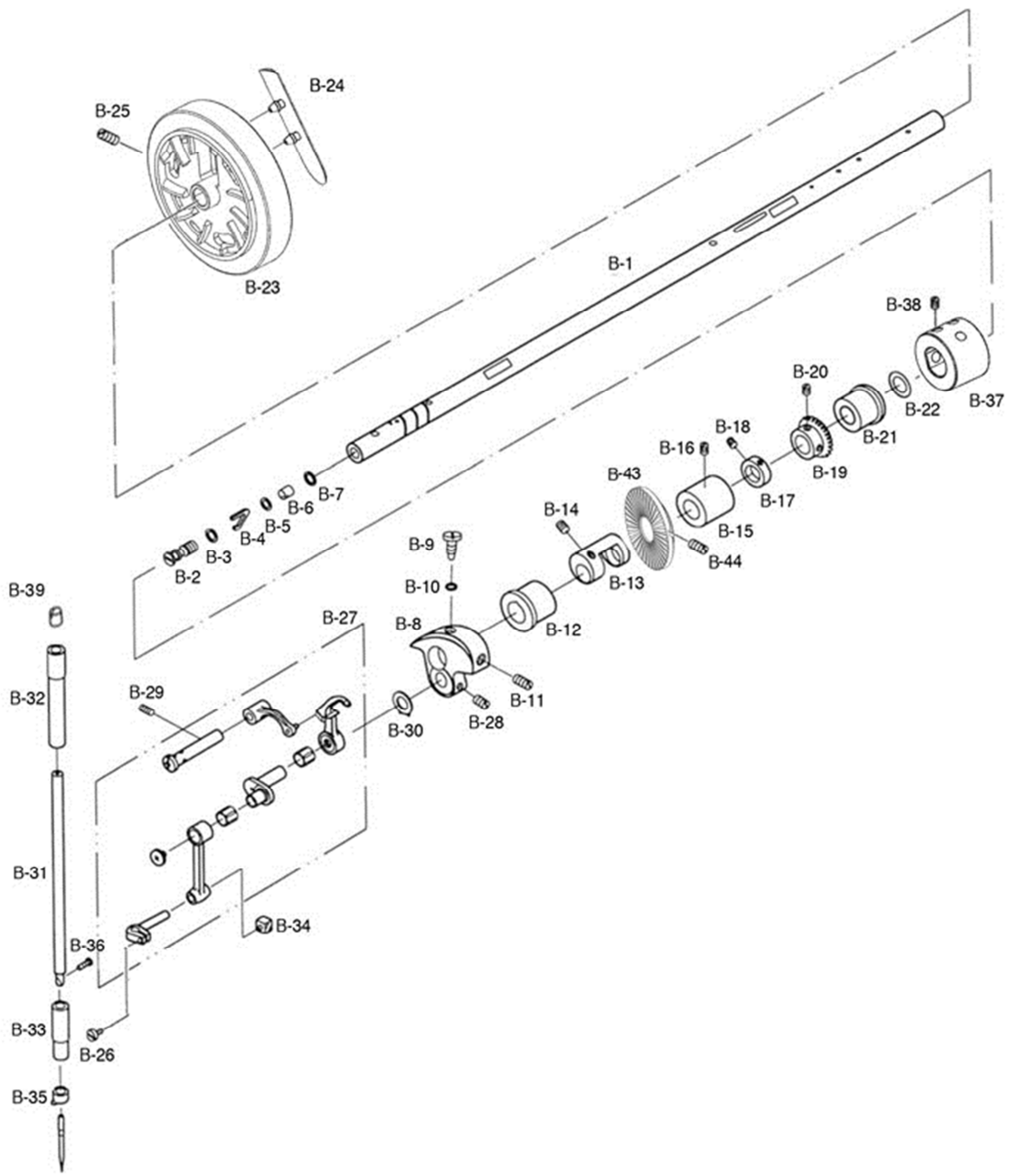

B 上轴针杆部件/Upper Shaft & Needle Bar Mechanism							
序号 No	公司件号	名称 PartName	零件描述 Description	数量			
				30-3Q	30-4Q	60-3Q	60-4Q
B-1	14202001	上轴	Upper Shaft	1		1	
B-2	14226003	上轴油量调节销	Oil Adjusting Pin For B-1	1		1	
B-3	114222002	调节销 O 型圈	O-Ring For B-2	2		2	
B-4	10123003	油芯	Spring for B-2	1		1	
B-5	14228001	油量调节销平面垫	Washer for B-6	1		1	
B-6	14223003	油量调节销滤油毡	Upper Shaft Felt	1		1	
B-7	14228002	油量调节销橡胶垫	Upper Shaft Urethan Washer	1		1	
B-8	14204001	针杆曲柄	Link Cam	1		1	
B-9	142S30004	针杆曲柄定位螺钉	Screw(9/32" n=28)	1		1	
B-10	114222002	针杆曲柄定位 o 型圈	O-Ring for B-9	1		1	
B-11	402S30005	针杆曲柄紧固螺钉	Screw(9/32" n=28)	1		1	
B-12	14203001	上轴前轴套	Upper Shaft Front Bushing	1		1	
B-13	14210001	上轴平衡块	Balance Cam	1		1	
B-14	409S14001	上轴平衡块螺钉	Screw(1/4" n=40)	2		2	
B-15	14203002	上轴中轴套	Upper Shaft Middle Bushing	1		1	
B-16	135S15008	上轴中轴套支头螺	Screw(15/64" n=28)	1		1	
B-17	14208001	上轴紧圈	Upper Shaft Collar	1		1	
B-18	101S15007	上轴紧圈螺钉	Screw(1/4" n=40)	2		2	
B-19	1422500100	上轴齿轮组件	Upper Shaft Gear Ass' v	1 组		1 组	
B-20	101S15002	上轴齿轮螺钉	Screw(1/4" n=40)	2		2	
B-21	14203003	上轴后轴套	Upper Shaft Rear Bushing	1		1	
B-22	14222020	上轴后轴套油封	Oil Seal for B-21	1		1	
B-23	14201003	手轮	Pulley	1		1	
B-24	14237005	商标牌	plate with trademark	1		1	
B-25	S10009	手轮紧固螺钉	Screw(15/64" n=28)	2		2	
B-26	101S11005	螺钉	Screw(9/64" n=40)	1		1	
B-27	1423800100	挑线杆组件	Thread Take-Up Lever	1 组		1 组	
B-28	101S15002	挑线曲柄定位螺钉	Screw(1/4" n=40)	2		2	
B-29	136S14002	挑线杆销紧固螺钉	Screw(15/64" n=28)	1		1	
B-30	14208002	挑线杆组件后定位	Protection Plate for B-8	1		1	
B-31	14202002	针杆	Needle Bar	1		1	
B-32	14203004	针杆上轴套	Needle Bar Upper Bushing	1			
B-33	14203005	针杆下轴套	Needle Bar Lower Bushing	1			
B-34	14209001	针杆接头滑块	Needle Bar Guide Slide Block	1			
B-35	13513011	针杆过线环	Needle Bar Thread Guide	1		1	
B-36	101S11006	针杆过线环螺钉	Screw(1/8" n=44)	1		1	
B-37	1420302800	联轴器组件	Coupling (type d)	1		1	
B-38	S10018	联轴器螺钉	Screw(M6)	6		6	
B-39	13523001	羊毛毡	Upper Shaft Felt	1			
B-43	14235001	绕线驱动轮	Winding wheel	1		2	

# C 竖轴下轴部件/Upright Shaft & Lower Shaft Mechanism

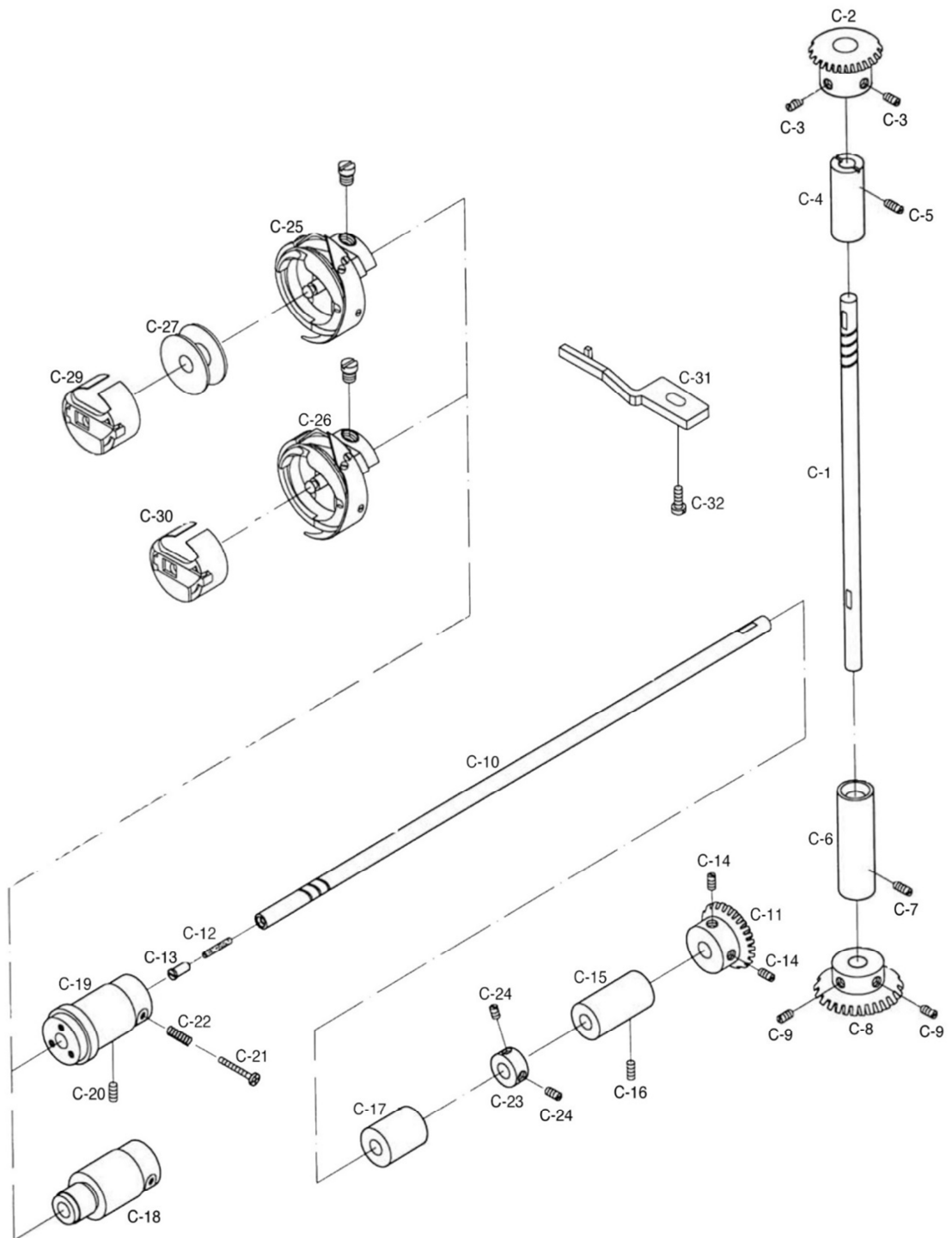

**C 竖轴下轴部件/Upright Shaft & Lower Shaft Mechanism**

序号 No	公司件号	名称 PartName	零件描述 Description	数量			
				30-3Q	30-4Q	60-3Q	60-4Q
C-1	14202003	竖轴	Upright Shaft	1		1	
C-2	14225002	竖轴上齿轮组件	Upright Shaft Upper Gear Asm	1		1	
C-3	101S15002	竖上齿轮螺钉	Screw(1/4" n=40)	2		2	
C-4	14203006	竖轴上轴套	Upright Shaft Upper Bushing	1		1	
C-5	135S15008	竖轴上轴套紧固螺	Screw(15/64" n=28)	1		1	
C-6	14203007	竖轴下轴套	Upright Shaft Lower Bushing	1		1	
C-7	135S15008	竖轴下轴套紧固螺	Screw(15/64" n=28)	1		1	
C-8	14225003	竖轴下齿轮组件	Upright Shaft Lower Gear Asm	1		1	
C-9	101S15002	竖轴下齿轮螺钉	Screw(1/4" n=40)	2		2	
C-10	14202004	下轴	Lower Shaft	1		1	
C-11	14225004	下轴齿轮	Lower Shaft Gear Asm	1		1	
C-12	10123003	下轴滤油塞	Lower Shaft Felt	1		1	
C-13	135S20007	下轴滤油塞螺钉	Cap Screw for Lower Shaft Oil	1		1	
C-14	101S15002	下轴齿轮紧固螺钉	Screw(1/4" n=40)	2		2	
C-15	14203008	下轴后轴套	Lower Shaft Rear Bushing	1		1	
C-16	135S15009	下轴后轴套紧固螺	Screw(15/64" n=28)	1		1	
C-17	14203009	下轴中轴套	Lower Shaft Middle Bushing	1		1	
C-18	14203010	下轴前轴套	Lower Shaft Front Bushing		1		1
C-19	14203011	下轴前轴套	Lower Shaft Front Bushing	1		1	
C-20	135S15008	下轴前轴套紧固螺	Screw(15/64" n=28)	1		1	
C-21	142S30007	下轴油量调节螺钉	Screw(3/16" n=32)	1		1	
C-22	14227002	油量调节弹簧	Spring for C-23	1		1	
C-23	10108002	下轴紧圈	Lower Shaft Collar	1		1	
C-24	101S11012	下轴紧圈螺钉	Screw(11/64" n=40)	2		2	
C-25	13618003	旋梭组件	Rotary Hook Asm	1		1	
C-26	10818001	旋梭组件	Rotary Hook Asm		1		1
C-27	10818501	梭心	Bobbin	1		1	
C-29	13618001	梭心套组件	Bobbin Case Asm				
C-30	10818502	梭心套组件	Bobbin Case Asm		1		1
C-31	13612005	旋梭定位勾	Inner Bobbin Stopper	1		1	
C-32	201S11020	旋梭定位勾螺钉	Screw(11/64" n=40)	1		1	





D 针距调节部件/Lower Feed Mechanism							
序号 No	公司件号	名称 PartName	零件描述 Description	数量			
				30-3Q	30-4Q	60-3Q	60-4Q
D-1	142S30008	针距调节螺杆	Feed Regulator Dial Shaft	1		1	
D-2	14222021	针距调节螺杆 O 型	O-Ring For D-1	1		1	
D-3	1421100100	针距标盘	Dial	1		1	
D-4	101S11022	针距标盘螺钉	Screw(3/16" n=28)	1		1	
D-5	11426022	止动销	Stopper pin	1		1	
D-6	11427034	止动销簧	Spring for stopper pin	1		1	
D-8	14201006	针距座	Feed Regulator	1		1	
D-9	14226005	针距座销	Feed Adjusting Shaft	1		1	
D-10	136S14002	针距座销支头螺钉	Screw(15/64" n=28)	1		1	
D-11	H05032	针距座销开口挡圈	E-Ring For D-8	1		1	
D-12	14227004	针距座拉簧	Spring For D-8	1		1	
D-13	14212013	针距座拉簧板	Holder For D-12	1		1	
D-14	402S11003	针距座拉簧板螺钉	Screw(11/64" n=40)	2		2	
D-15	14202005	倒缝扳手轴	Reverse feed lever shaft	1		1	
D-16	O01137	O 型圈	O-Ring For D-15	1		1	
D-18	1420400300	倒缝扳手曲柄组件	Reverse Feed Lever Crank	1 组		1 组	
D-19	409S11015	倒缝扳手曲柄夹紧	Screw(3/16" n=28)	1		1	
D-20	201S11020	倒缝扳手曲柄支头	Screw(11/64" n=40)	1		1	
D-21	14227005	倒缝扳手曲柄拉簧	Return Spring For D-17, D-18	1		1	
D-24	14205001	针距连杆	Connecting Rod For Feed	1		1	
D-25	14226006	针距连杆销	Pin For D-24	1		1	
D-26	S09006	螺钉 M4×4	Screw(M4)	1		1	
D-28	14205002	倒缝连杆	B/T Solenoid Crank	1		1	
D-29	14226007	倒缝连杆销	Pin For D-28	1		1	
D-30	H05029	倒缝连杆销开口挡	E-Ring For D-29	1		1	
D-31	14212064	倒缝连杆垫圈	B/T Solenoid Crank Spacer	1		1	
D-32	14202023	倒缝台	Feed Regulator Shaft	1		1	
D-33	14203025	倒缝台轴套	Feed Regulator Shaft Bushing	1		1	
D-34	135S15008	倒缝台轴套紧固螺	Screw(15/64" n=28)	1		1	
D-35	14208001	倒缝台紧圈	Stopper Collar For D-32	1		1	
D-36	101S15007	倒缝台紧圈螺钉	Screw(1/4" n=40)	2		2	
D-37	14212065	倒缝台滑块导板	Slide Block Guide Plate	2		2	
D-38	101S11008	滑块导轨螺钉	Screw(11/64" n=40)	4		4	
D-39	14209012	倒缝台滑块	Slide Block	2		2	
D-40	14202024	倒缝台滑块轴	Slide Block Shaft	1		1	
D-41	14202025	倒缝台支承轴	Reverse Shaft For D-32	1		1	
D-42	14226020	倒缝台支承轴销	Connecting Pin For D-41	1		1	
D-43	136S14002	支承轴紧固螺钉	Screw(15/64" n=28)	1		1	
D-44	14210006	拾牙送布凸轮	Feed Cam	1		1	
D-45	101S15007	拾牙送布凸轮螺钉	Screw(1/4" n=40)	2		2	
D-46	H04003	送布凸轮开口挡圈	C-Ring For D-44	1		1	
D-47	14205012	送布连杆	Connecting Rod For D-44	1		1	
D-48	14226023	送布连杆销	Pin For D-47	1		1	
D-49	406S11009	送布连杆销螺钉	Screw(11/64" n=40)	1		1	
D-50	14205013	送布轴连杆	Feed Connecting Rod	1		1	
D-51	14226021	送布轴连杆下连杆	Pin For D-50	1		1	

# D 针距调节部件/Lower Feed Mechanism

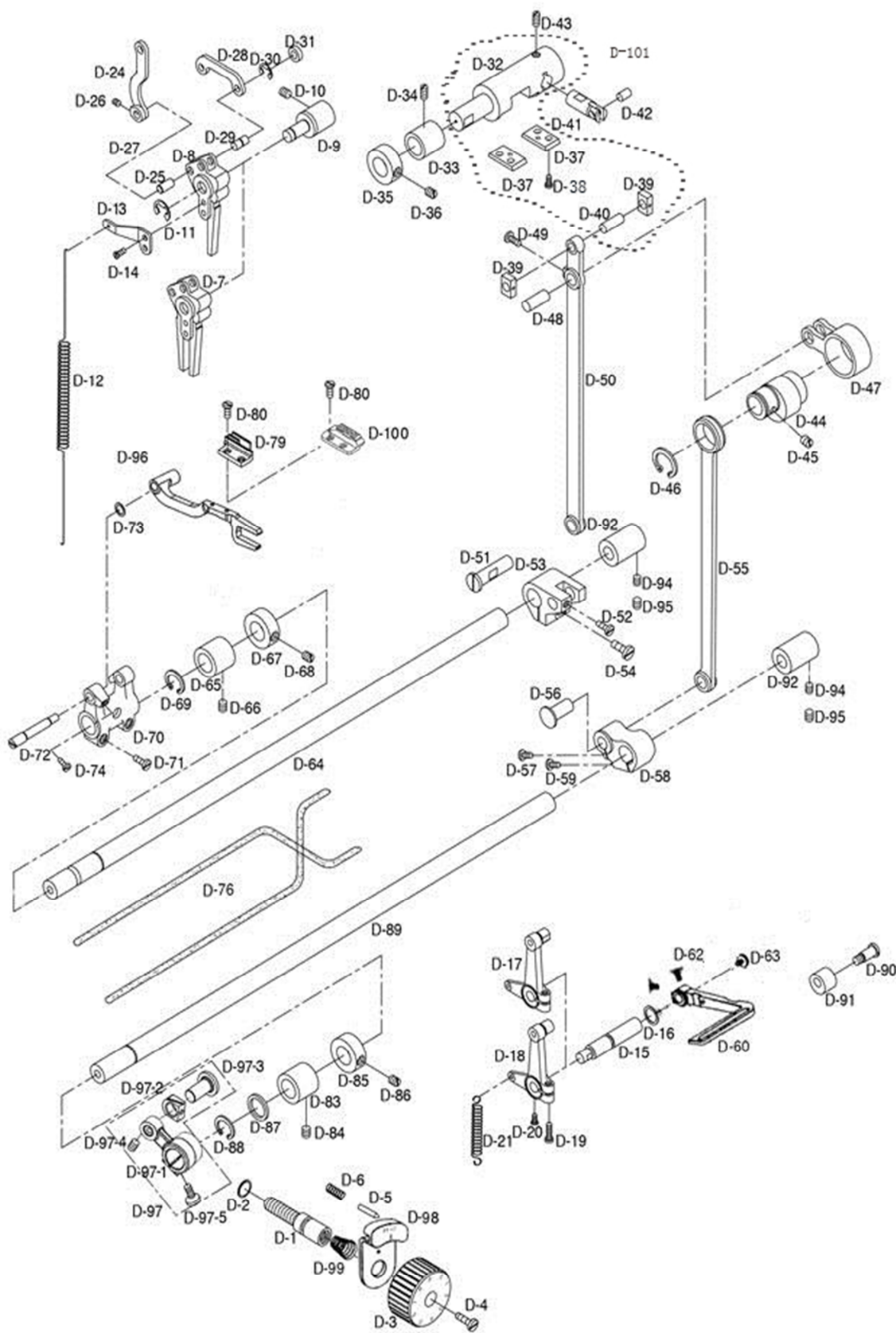

D 针距调节部件/Lower Feed Mechanism							
序号 NO.	公司件号	名称 PartName	零件描述 Description	数量			
				30-3Q	30-4Q	60-3Q	60-4Q
D-52	135S11009	下连杆销支头螺钉	Screw(15/64" n=28)	1		1	
D-53	14204021	送布轴连杆下曲柄	Level Feed Shaft Crank(Rear)	1		1	
D-54	135S13002	送布轴连杆下曲柄	Screw(15/64" n=28)	1		1	
D-55	14205014	抬牙连杆	Crank Rod	1		1	
D-56	14226022	抬牙连杆销	Connecting Pin for D-55	1		1	
D-57	135S11048	抬牙连杆销支头螺	Screw(3/16" n=32)	1		1	
D-58	14204022	抬牙后曲柄	Feed Lifting Shaft Crank(Rear)	1		1	
D-59	135S11048	抬牙后曲柄夹紧螺	Screw(3/16" n=32)	1		1	
D-60	13531001	倒缝扳手(301763)	Reverse feed lever	1		1	
D-62	135S11009	倒缝扳手夹紧螺钉	Screw(15/64" n=28)	2		2	
D-63	135S11022	倒缝扳手轴螺钉	Screw(3/16" n=28)	1		1	
D-64	14202006	送布轴	Level Feed Shaft	1		1	
D-65	14203012	送布轴左轴套	Level Feed Shaft Bushing	1		1	
D-66	409S15004	送布轴左轴套紧固	Screw(15/64" n=28)	1		1	
D-67	10108003	送布轴紧圈	Collar for D-64	1		1	
D-68	135S15004	送布轴紧固螺钉	Screw(1/4" n=40)	2		2	
D-69	H03001	送布轴开口挡圈	C-Ring for D-64	1		1	
D-70	14204004	牙架曲柄	Feed Bar Crank	1		1	
D-71	101S11016	牙架曲柄夹紧螺钉	Screw(3/16" n=28)	2		2	
D-72	14202007	牙架偏心轴	Feed Bar Shaft	1		1	
D-73	13528004	牙架偏心轴垫圈	Washer For D-72	1		1	
D-74	406S11009	牙架偏心轴螺钉	Screw(11/64" n=40)	1		1	
D-76	10423005	送布抬牙轴油线	Oil wick	2		2	
D-79	14214001	送布牙	Feed Dog	1			
D-80	101S11018	送布牙螺钉	Screw(1/8" n=44)	2		2	
D-83	14203025	抬牙轴左轴套	Feed Lifting Shaft Bushing	1		1	
D-84	135S15009	抬牙轴左轴套螺钉	Screw(15/64" n=28)	1		1	
D-85	10108003	抬牙轴紧圈	Collar for D-89	1		1	
D-86	135S15004	抬牙轴紧圈螺钉	Screw(1/4" n=40)	2		2	
D-87	14212018	抬牙轴左轴套垫圈	Washer for D-89	1		1	
D-88	H03001	抬牙轴开口挡圈	C-Ring for D-89	1		1	
D-89	14202008	抬牙轴	Feed Lifting Shaft	1		1	
D-90	142S20001	倒缝扳手定位圈螺	Stud Screw for D-91	1		1	
D-91	14222023	倒缝扳手定位圈	Upper Stopper Rubber for	1		1	
D-92	14203014	抬牙送布轴右轴套	Lifting tooth feeding shaft	2		2	
D-94	409S15004	送布轴右轴套螺钉	Screw(15/64" n=28)	1		1	
D-95	135S15009	抬牙轴右轴套螺钉	Screw(15/64" n=28)	1		1	
D-96	14206002	牙架	Feed bar asm	1		1	
D-97	1420600100	抬牙曲柄组件	Crank assembly	1 组		1 组	
D-97-1	14205003	抬牙曲柄	Lift crank	1		1	
D-97-2	14209002	抬牙滑块	Lifting block	1		1	
D-97-3	14202009	抬牙滑块轴	Lift shaft	1		1	
D-97-4	406S11009	抬牙销螺钉	Screw	1		1	
D-97-5	101S11016	抬牙曲柄螺钉	Screw	1		1	
D-98	14212068	按键	Feed regulator key-press	1		1	
D-99	13527009	按键簧	Dial spring for stopper pin	1		1	
D-100	14214002	送布牙(三同步)	Send Bougat (triple sync)			1	
D-101	1420202300	倒缝台组件	Feed Regulator Shaft Asm.	1		1	

# E 剪线部件/Thread Trimmer Mechanism

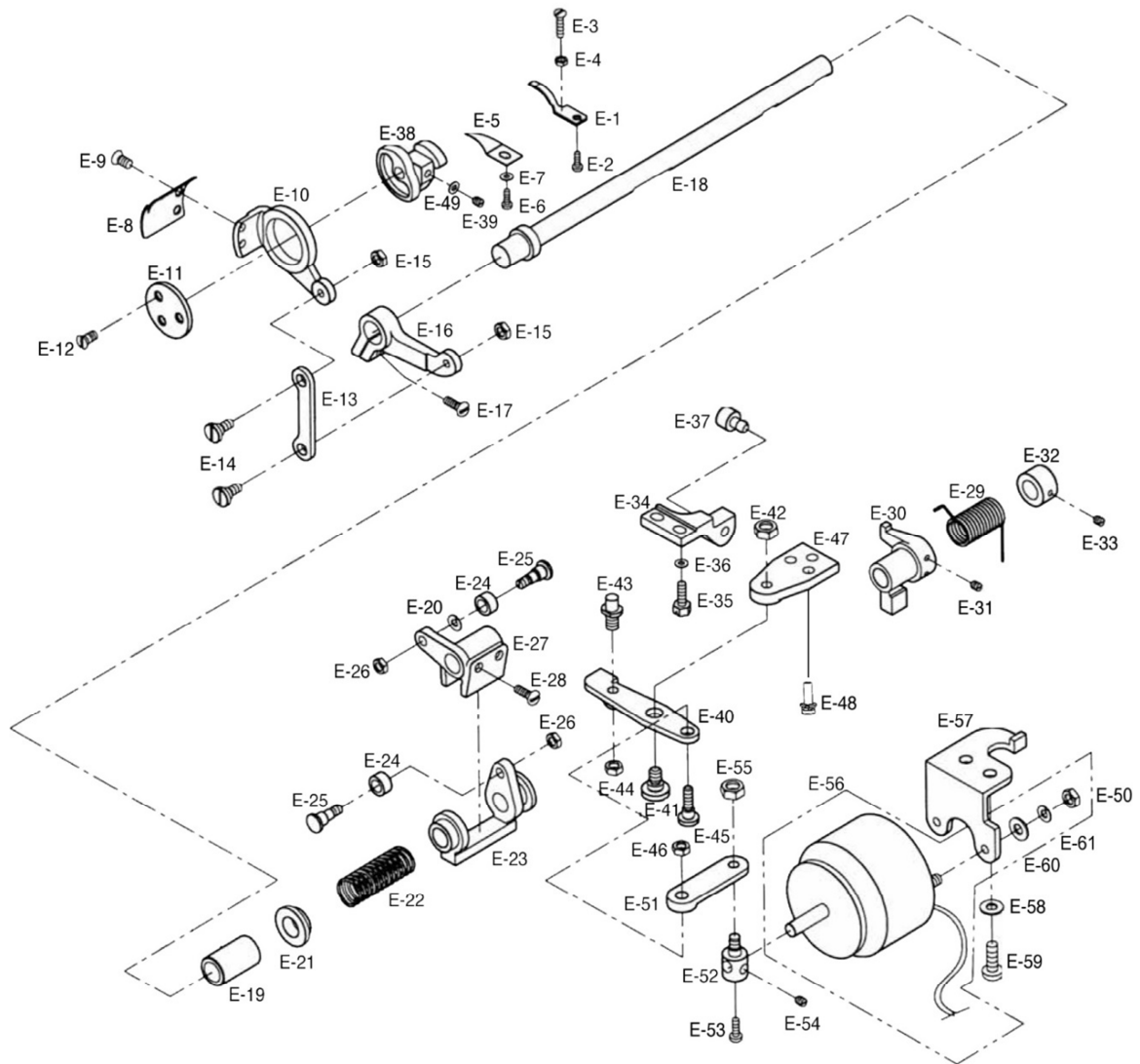

E 剪线部件/Thread Trimmer Mechanism							
序号 No	公司件号	名称 PartName	零件描述 Description	数量			
				30-3Q	30-4Q	60-3Q	60-4Q
E-1	13619001	定刀	Fixed Mes	1		1	
E-2	136S17001	定刀螺钉	Screw(9/64" n=40)	1		1	
E-3	113S15002	定刀压力调节螺钉	Screw(1/8" n=40)	1		1	
E-4	402S16007	压力调节螺钉锁紧	Nut(1/8" n=40)	1		1	
E-5	14212019	分线板	Thread Retaining Plate	1		1	
E-6	406S11009	分线板螺钉	Screw(11/64" n=40)	1		1	
E-7	42128003	分线板螺钉垫圈	Washer for E-5	1		1	
E-8	13619002	动刀	Rotary Mes	1		1	
E-9	136S17003	动刀螺钉	Screw(11/64" n=40)	2		2	
E-10	14204005	动刀架	Thread Trimming Holder	1		1	
E-11	14212021	动刀架压板	Thread Trimming Holder	1		1	
E-12	136S17001	动刀架压板螺钉	Screw(9/64" n=40)	3		3	
E-13	14205004	切刀连杆	Thread Trimming Lever	1		1	
E-14	142S20002	切刀连杆轴位螺钉	Stud Screw for E-13	2		2	
E-15	116S16006	切刀连杆轴位螺母	Nut for E-14	2		2	
E-16	14204006	切刀驱动曲柄	Thread Trimming Lever	1		1	
E-17	413S13023	切刀驱动曲柄夹紧	Screw(M6)	1		1	
E-18	14202010	切刀驱动轴	Thread Trimming Shaft	1		1	
E-19	14203015	切刀驱动轴轴套	Thread Trimming Shaft	1		1	
E-20	W02001	弹簧垫圈	Spring Washer	2		2	
E-21	13601010	切线凸轮轴曲柄端	Guide Bush for Return Spring	1		1	
E-22	13627005	切线凸轮曲柄复位	Slide Arm Return Spring	1		1	
E-23	14204007	凸轮右曲柄	Slide Arm	1		1	
E-24	14208007	凸轮左右曲柄滚柱	Roller	2		2	
E-25	142S20003	滚柱轴位螺钉	Stud Screw for E-24	2		2	
E-26	142S16005	滚柱轴位螺母	Nut(3/16" n=32)	2		2	
E-27	14204008	凸轮左曲柄	Cam Follower Crank	1		1	
E-28	136S14002	凸轮左曲柄螺钉	Screw(15/64" n=28)	2		2	
E-29	14227007	驱动轴复位簧	Return Spring	1		1	
E-30	14204009	驱动轴复位块	Stopper Lever	1		1	
E-31	136S14002	驱动轴复位块螺钉	Screw(15/64" n=28)	2		2	
E-32	20108001	驱动轴紧圈	Collar for E-18	1		1	
E-33	201S14002	驱动轴紧圈螺钉	Screw(11/64" n=40)	2		2	
E-34	14209003	驱动轴限位块	Stopper	1		1	
E-35	135S11048	驱动轴限位块螺钉	Screw(3/16" n=32)	2		2	
E-36	40928020	驱动轴限位块螺钉	Washer	2		2	
E-37	14222024	限位块缓冲垫	Stopper Lever Cushion Rubber	1		1	
E-38	13610003	切线凸轮	Mes Cam	1		1	
E-39	116S14005	切线凸轮螺钉	Screw(1/4" n=40)	2		2	
E-40	14212023	电磁铁连杆杠杆	Clutch Lever	1		1	
E-41	142S20004	杠杆中轴位螺钉	Stud Screw for E-38	1		1	
E-42	409S16020	限位调节螺母	Nut(15/64" n=28)	1		1	
E-43	142S30009	杠杆限位调节螺钉	Stud Screw for E-38	1		1	
E-44	409S16020	限位调节螺母	Nut(15/64" n=28)	1		1	
E-45	142S20005	电磁铁连杆轴位螺	Stud Screw for E-47	1		1	
E-46	116S16006	电磁铁连杆轴位螺	Nut(3/16" n=32)	1		1	

# E 剪线部件/Thread Trimmer Mechanism

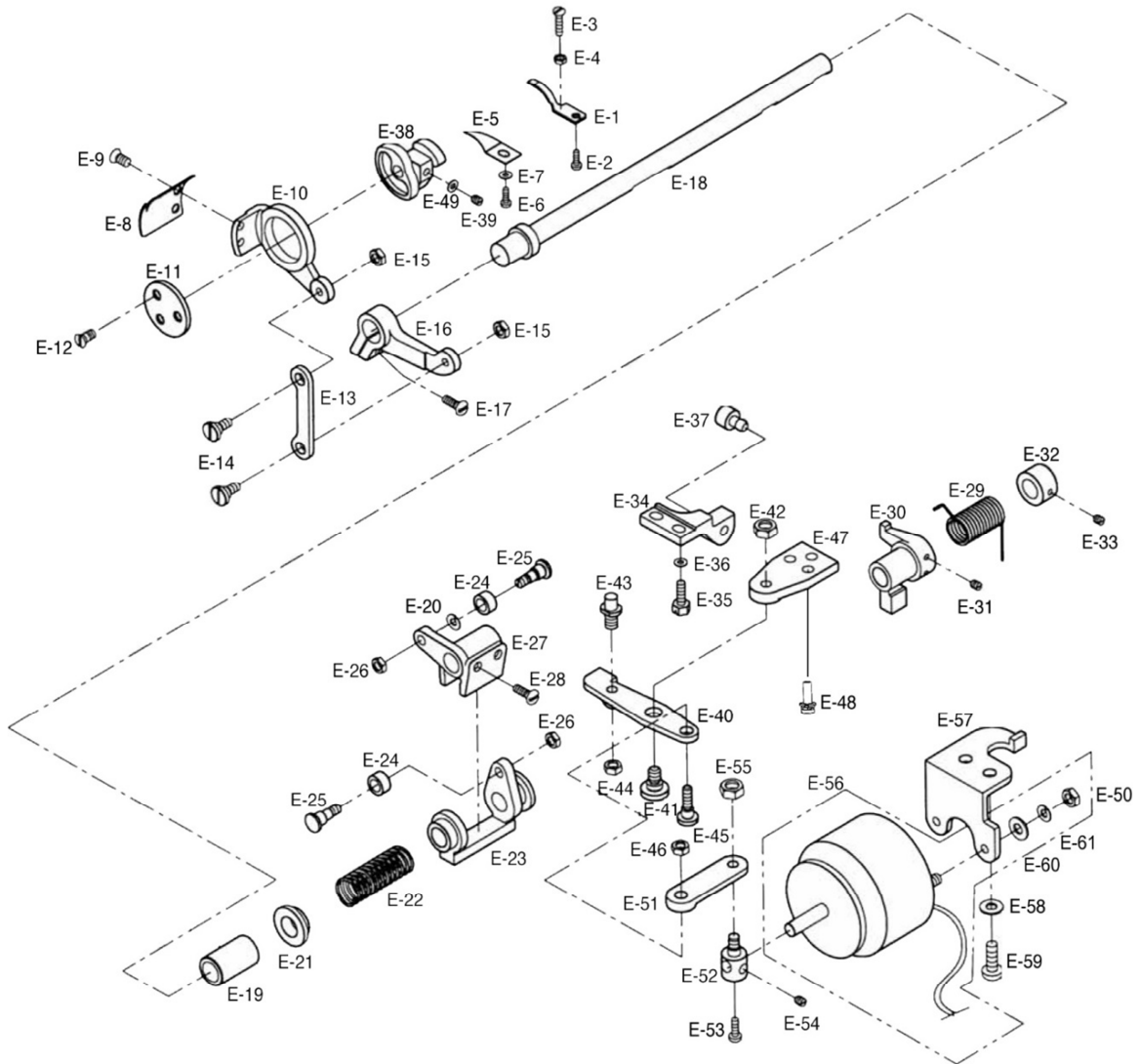

**E 剪线部件/Thread Trimmer Mechanism**

序号 No	公司件号	名称 PartName	零件描述 Description	数量			
				30-3Q	30-4Q	60-3Q	60-4Q
E-47	14212024	连杆杠杆连接板	Base Plate	1		1	
E-48	417S30306	螺钉带垫 M5x15	Screw(M5)	3		3	
E-49	13628003	切线凸轮螺钉垫圈	Washer For E-39	2		2	
E-50	N01001	螺母 M4	Screw(M4)	2		2	
E-51	14205005	电磁铁连杆	Solenoid Connecting Link	1		1	
E-52	14226008	电磁铁连杆销	Solenoid Pin	1		1	
E-53	402S11003	电磁铁连杆销螺钉	Screw(11/64" n=40)	1		1	
E-54	125S15003	电磁铁连杆销紧固	Screw(11/64" n=40)	1		1	
E-55	N01004	电磁铁连杆销螺母	Nut(M5)	1		1	
E-56	1423000500	切刀电磁铁组件	Thread Trimming Solenoid	1		1	
E-57	14212027	电磁铁固定架	Base for E-51	1		1	
E-58	W02004	电磁铁固定架弹簧	Washer	2		2	
E-59	401S13001	电磁铁固定架螺钉	Screw(15/64" n=28)	2		2	
E-60	W01001	垫圈	Washer	2		2	
E-61	W02018	弹簧垫圈	Spring Washer	2		2	



F 上送料部件/Thread Trimmer Mechanism

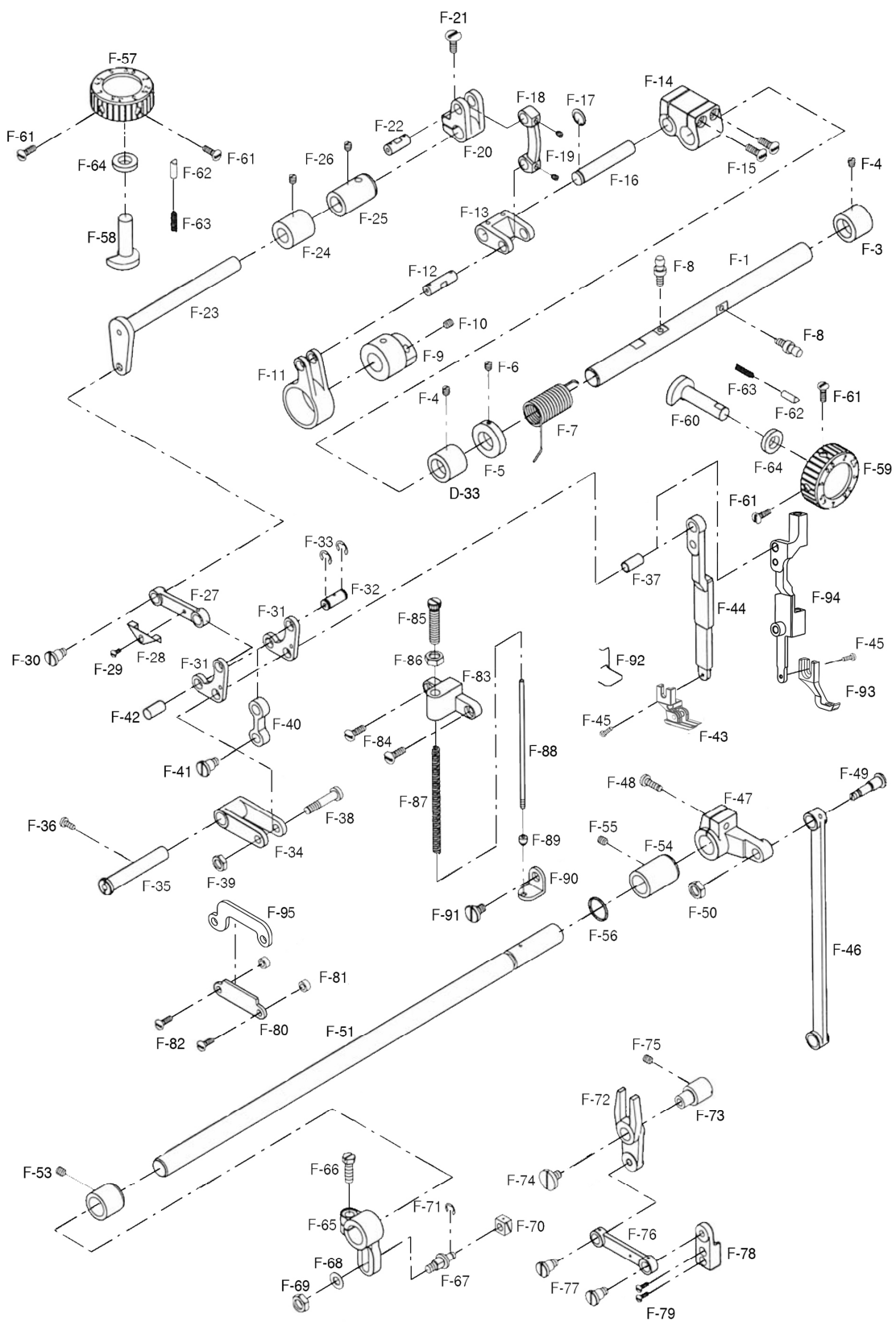

F 上送料部件/Thread Trimmer Mechanism							
序号 No	公司件号	名称 PartName	零件描述 Description	数量			
				30-3Q	30-4Q	60-3Q	60-4Q
F-1	14202011	压脚提升调节轴	Climb Device Adjusting Shaft	1		1	
D-33	14203025	压脚提升调节轴左轴	Climb Device Adjusting Shaft	1		1	
F-3	14203018	压脚提升调节轴右轴	Climb Device Adjusting Shaft	1		1	
F-4	125S15003	压脚提升调节轴轴套	Screw(11/64" n=40)	1		1	
F-5	10108003	紧圈	Collar for F-1	2		2	
F-6	135S15004	紧圈螺钉	Screw(1/4" n=40)	4		4	
F-7	14227008	压脚提升轴复位簧	Return Spring for F-1	1		1	
F-8	142S30010	压脚提升轴螺钉	Holder for F-7	2		2	
F-9	14210003	送料左曲柄凸轮	Upper Feed Driving	1		1	
F-10	101S15007	送料左曲柄凸轮螺钉	Screw(1/4" n=40)	2		2	
F-11	14204010	送料左曲柄	Upper Feed Driving	1		1	
F-12	14226009	送料左曲柄销	Connecting Pin for F-11	1		1	
F-13	14204011	压脚提升轴支架曲柄	Connecting Link for F-11	1		1	
F-14	14202012	压脚提升轴支架	Upper Feed Driving Control	1		1	
F-15	101S11016	压脚提升轴支架螺钉	Screw(3/16" n=40)	4		4	
F-16	14202013	压脚提升轴支架轴	Connecting Shaft for F-14	1		1	
F-17	H05011	支架轴开口挡圈	C-Ring for F-16	1		1	
F-18	14205006	提升轴调节曲柄连杆	Upper Feed Driving	1		1	
F-19	113S14002	提升轴调节曲柄连杆	Screw(11/64" n=40)	2		2	
F-20	14204012	提升轴调节曲柄	Upper Feed Driving Crank	1		1	
F-21	401S11009	提升轴调节曲柄夹紧	Screw(15/64" n=28)	1		1	
F-22	14226010	提升轴调节曲柄销	Connecting Pin for F-20	1		1	
F-23	14202014	压脚提升轴组件	Upper Feed Driving Shaft	1		1	
F-24	14203019	压脚提升轴左轴套	Upper Feed Driving Shaft	1		1	
F-25	14203020	压脚提升轴右轴套	Upper Feed Driving Shaft	1		1	
F-26	135S15008	提升轴左右轴套螺钉	Screw(15/64" n=28)	2		2	
F-27	14205007	压脚送料曲柄连杆	Upper Feed Driving Rod	1		1	
F-28	14212029	压脚送料曲柄连杆油	Upper Feed Driving Rod	1		1	
F-29	101S11005	连杆油线夹螺钉	Screw(9/64" n=40)	1		1	
F-30	142S20006	压脚送料曲柄连杆轴	Hinge Screw for Upper Feed	1		1	
F-31	14204013	压脚送料曲柄	Upper Feed Connecting Link	2		2	
F-32	14202015	送料曲柄铰链轴	Upper Feed Connecting Link	1		1	
F-33	H05031	送料曲柄铰链轴开口	E-Ring for F-32	2		2	
F-34	14204014	压脚送料曲柄支架	Upper Feed Lever Rock	1		1	
F-35	14204015	送料曲柄轴	Upper Feed Lever Rock	1		1	
F-36	135S15009	送料曲柄轴螺钉	Screw(15/64" n=28)	1		1	
F-37	14203021	压脚连杆销套	Upper Feed Lever	1		1	
F-38	142S20007	送布曲柄连杆轴位螺	Upper Feed Lever Driving	1		1	
F-39	409S16020	送布曲柄连杆轴位螺	Nut(15/64" n=28)	1		1	
F-40	14205008	送料曲柄连杆	Presser Bar Bracket	1		1	
F-41	142S20006	送料曲柄连杆轴位螺	Hinge Screw for F-40	1		1	
F-42	14226011	送料曲柄铰链销	Pin for F-40	1		1	
F-43	1421600100	压脚组件	Upper Feed Presser Foot	1			
F-44	14205009	压脚连杆	Upper Feed Lever	1			
F-45	135S11030	压脚螺钉	Screw(9/64" n=40)	1		1	
F-46	14205010	压脚摆动轴右曲柄连	Upper Feed Lever Level	1		1	
F-47	14204016	压脚摆动轴右曲柄	Upper Feed Lever Level	1		1	
F-48	135S13002	压脚摆动轴右曲柄夹	Screw(15/64" n=28)	1		1	

F 上送料部件/Thread Trimmer Mechanism

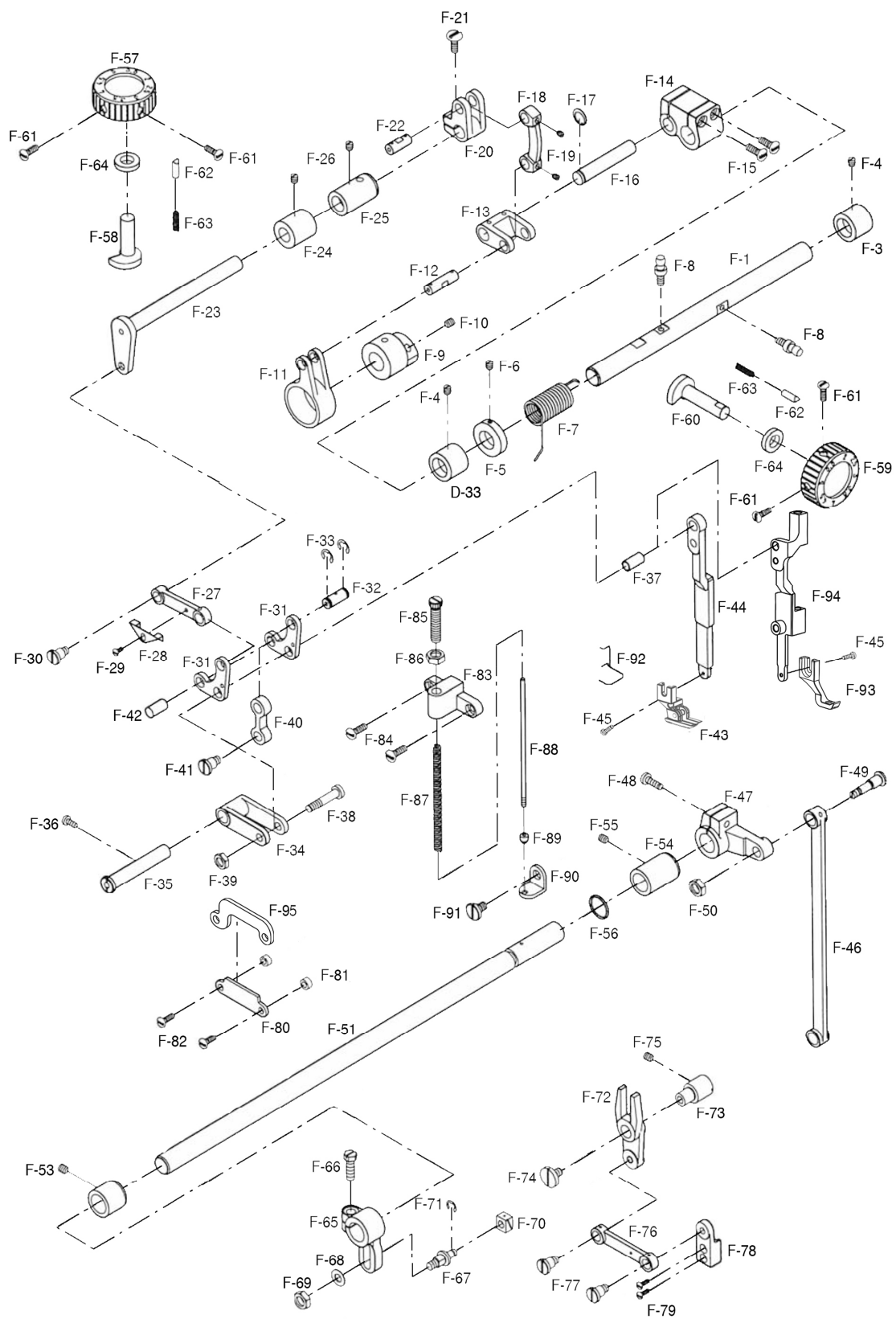

F 上送料部件/Thread Trimmer Mechanism							
序号 No	公司件号	名称 PartName	零件描述 Description	数量			
				30-3Q	30-4Q	60-3Q	60-4Q
F-49	142S20009	右曲柄连杆轴位螺	Screw(9/32" n=28)	1		1	
F-50	135S16006	右曲柄连杆轴位螺	Nut(9/32" n=28)	1		1	
F-51	14202016	压脚摆动轴	Upper Feed Lever Level	1		1	
D-92	14203014	拾牙送布轴右轴套	Upper Feed Lever Level	1		1	
F-53	135S15008	压脚摆动轴左轴套	Screw(15/64" n=28)	1		1	
F-54	14203023	压脚摆动轴右轴套	Upper Feed Lever Level	1		1	
F-55	409S15004	压脚摆动轴右轴套	Screw(15/64" n=28)	1		1	
F-56	O01046	压脚摆动轴 O 型圈	O-Ring for F-51	1		1	
F-57	1421100200	压脚调节上盖标盘	Climb Device Dial Ass' v(Top	1		1	
F-58	14210004	上盖标盘调节凸轮	Climb Device Eccentric	1		1	
F-59	1421100300	压脚调节机头标盘	Climb Device Dial Ass' y(Arm)	1		1	
F-60	14210005	机头标盘调节凸轮	Climb Device Eccentric	1		1	
F-61	101S15010	调节凸轮支头螺钉	Screw(15/64" n=28)	4		4	
F-62	14226012	标盘止动销	Pin for F-57, F-59	2		2	
F-63	14227009	标盘止动销簧	Spring for F-62	2		2	
F-64	14212031	调节凸轮垫片	Climb Device Dial Support	2		2	
F-65	13504008	压脚摆动轴左曲柄	Upper Feed Lever Level	1		1	
F-66	135S11032	压脚摆动轴左曲柄	Screw(15/64" n=28)	1		1	
F-67	1420900400	摆动轴左曲柄调节	Upper Feed Level Adjusting				
F-67	142S30011	摆动轴左曲柄调节	Upper Feed Level Adjusting	1		1	
F-68	11628005	曲柄调节柱垫圈	Washer for F-67	1		1	
F-69	413S16005	曲柄调节柱螺母	Nut(M6)	1		1	
F-70	14209004	曲柄调节柱滑块	Block for F-67	1		1	
F-71	H05029	曲柄调节柱开口挡	E-Ring for F-67	1		1	
F-72	14204018	提升压脚摆动曲柄	Upper Feed Level Driving Link	1		1	
F-73	14202017	提升压脚摆动曲柄	Hinge Shaft for F-72	1		1	
F-74	142S11044	提升压脚摆动曲柄	Set Screw for F-72	1		1	
F-75	135S15008	曲柄支点轴螺钉	Screw(15/64" n=28)	1		1	
F-76	14205011	摆动曲柄连杆	Upper Feed Level Driving Rod	1		1	
F-77	142S20006	摆动曲柄连杆轴位	Hinge Screw for F-76	2		2	
F-78	14204019	摆动曲柄连杆座	Upper Feed Level Holder	1		1	
F-79	101S11005	摆动曲柄连杆座螺	Screw(9/64" n=40)	2		2	
F-80	14212034	压脚连杆导板	Upper Feed Lever Support	1			
F-81	14209005	压脚连杆导板垫块	Upper Feed Lever Support	2		2	
F-82	116S11005	压脚连杆导板螺钉	Screw(11/64" n=40)	2		2	
F-83	14209006	提升压脚调节架	Frame for Upper Feed	1		1	
F-84	201S11020	提升压脚调节架螺	Screw(11/64" n=40)	2		2	
F-85	135S30007	提升压脚调节螺钉	Screw(9/32" n=28)	1		1	
F-86	135S16006	提升压脚调节螺钉	Nut(9/32" n=28)	1		1	
F-87	14227010	提升压脚簧	Upper Feed Pressure	1		1	
F-88	1350202100	压脚簧导柱	Upper Feed Pressure	1		1	
F-89	13502027	压脚簧导柱头	Fulcrum for F-87	1		1	
F-90	14209009	压脚簧导柱导向块	Fulcrum for F-88	1		1	
F-91	135S11036	压脚簧导柱导向块	Hinge Screw for F-90	1		1	
F-92	14227011	护指簧	Needle Bar Safety Guide	1		1	
F-93	14216005	内压脚（三同步）	Internal pressure foot (triple			1	
F-94	14205015	压脚连杆（三同步）	Pin Rod (triple sync)			1	
F-95	14212062	压脚连杆导板（三同	Pin-Lever guide plate (triple			1	

# G 压脚调节部件/Presser Foot&Tension Release Mechanism

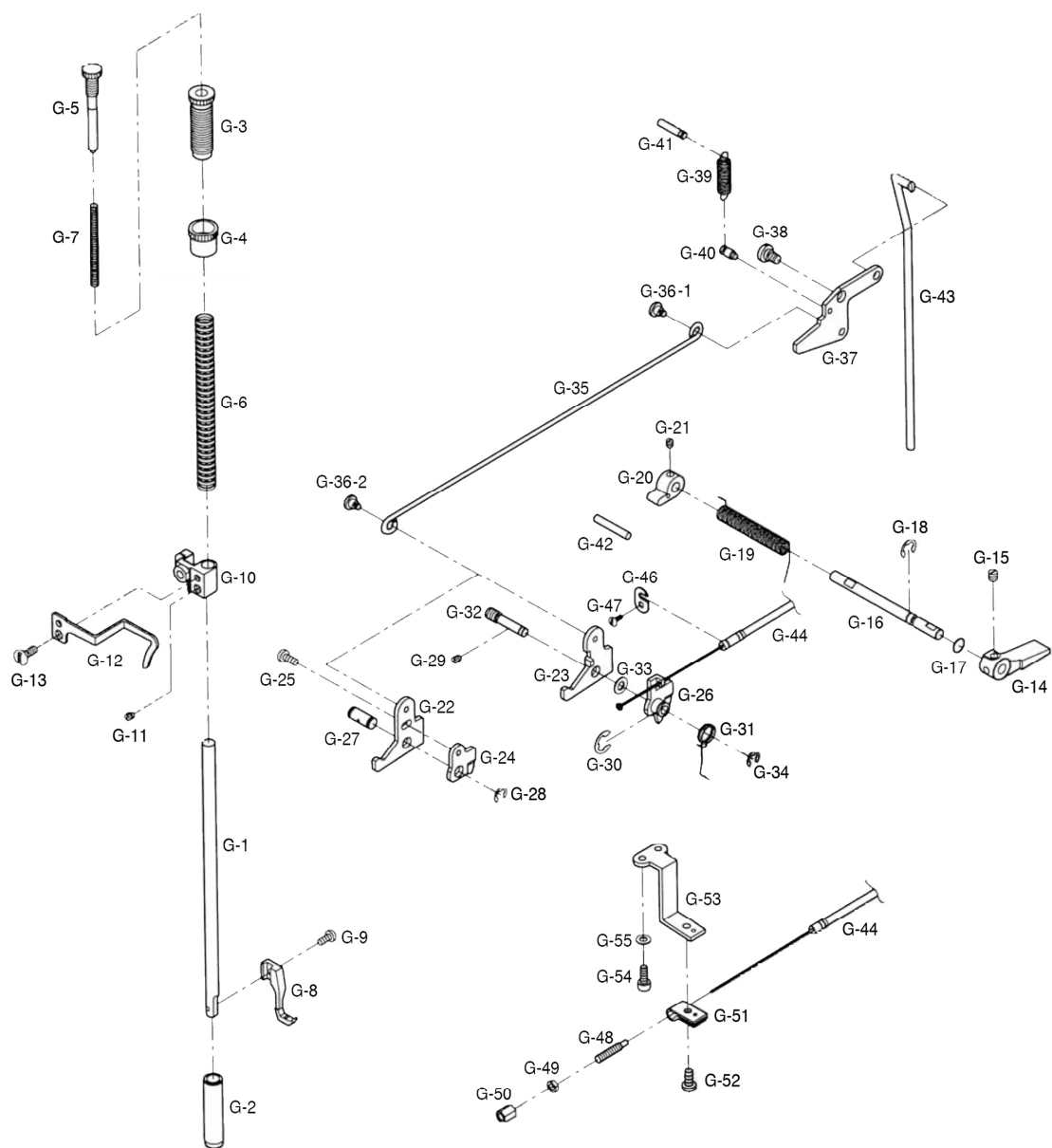

G 压脚调节部件/Presser Foot&Tension Release Mechanism							
序号 No	公司件号	名称 PartName	零件描述 Description	数量			
				30-3Q	30-4Q	60-3Q	60-4Q
G-1	14202018	压紧杆	Presser bar	1		1	
G-2	14203024	压紧杆轴套	Presser bar bushing	1		1	
G-3	135S30004	调压螺钉	Pressure Adjusting Screw	1		1	
G-4	135S16003	调压螺钉锁紧螺母	Nut for Pressure Adjusting	1		1	
G-5	135S30005	小压脚调节螺钉	Sub Pressure Adjusting	1		1	
G-6	14227012	调压簧	Pressure Adjusting Spring	1		1	
G-7	13527012	小压脚调节螺钉簧	Sub Pressure Adjusting	1		1	
G-8	14216002	小压脚	Sub Press Foot	1			
G-9	135S11030	小压脚螺钉	Screw(9/64" n=40)	1		1	
G-10	14209010	压紧杆导架	Presser Bar Bracket	1		1	
G-11	135S11001	压紧杆导架螺钉	Screw(15/64" n=28)	1		1	
G-12	14213009	大线勾	Thread Guide Plate	1		1	
G-13	401S11031	大线勾螺钉	Screw(11/64" n=40)	1		1	
G-14	14216003	压脚扳手	Presser Bar Lifter	1		1	
G-15	409S15004	压脚扳手螺钉	Screw	2		2	
G-16	14202019	压脚扳手轴	Presser Bar Lifter Shaft	1		1	
G-17	14222018	压脚扳手轴 O 型圈	O-Ring for G-16	1		1	
G-18	H05013	压脚扳手轴开口挡圈	E-Ring for G-16	1		1	
G-19	14227014	压脚扳手轴扭簧	Torsion Spring for G-14	1		1	
G-20	14209011	压脚扳手凸轮	Presser Lifter Cam	1		1	
G-21	135S15004	压脚扳手凸轮螺钉	Screw(1/4" n=40)	1		1	
G-22	14212036	膝控提升杠杆(左)	Knee control lifting Lever		1		1
G-23	14212037	膝控提升杠杆(右)	Knee Control lifting Lever	1		1	
G-24	14212038	松线凸轮板	Loose WIRE CAM Plate		1		1
G-25	402S11003	膝控提升杠杆左螺钉	Screw(11/64" n=40)		1		1
G-26	14212039	松线板组件	Pine Board components	1		1	
G-26-	14212069	松线板底板	Pine Board floor	1		1	
G-26-	14202031	松线板连接轴	Loose wire connection sha	1		1	
G-27	14226013	支点销轴	Pivot PIN SHAFT		1		1
G-28	H05013	支点销轴开口挡圈			1		1
G-29	125S15003	支点轴螺钉	Screw(11/64" n=40)	1		1	
G-30	H05033	钢绳上开口挡圈		1		1	
G-31	14227015	钢绳上扭簧	Spring for G-26	1		1	
G-32	14202020	膝控提升杠杆(左)支	Shaft for G-26	1		1	
G-33	41728005	支点轴垫圈	Washer for G-32	1		1	
G-34	H05006	支点轴开口挡圈		1		1	
G-35	14212044	膝控提升杠杆	Presser Bar Lifting Link	1		1	
G-36-	135S11027	膝控提升杠杆轴位螺钉	Hinge Screw for Presser	1		1	
G-36-	142S11052	膝控提升杠杆轴位螺钉	Hinge Screw for Presser	1		1	
G-37	14212045	膝控提升杠杆(右)	Knee Lifting Link	1		1	
G-38	142S11053	膝控提升杠杆(右)螺钉	Hinge Screw for G-37	1		1	
G-39	14227016	膝控提升杠杆(右)拉簧	Spring for G-37	1		1	
G-40	14226014	拉簧下勾销	Connecting Screw for G-39	1		1	
G-41	13526005	拉簧上勾销	Holder for G-39	1		1	
G-42	14226016	限位销	Stopper Pin for G-20	1		1	

# G 压脚调节部件/Presser Foot&Tension Release Mechanism

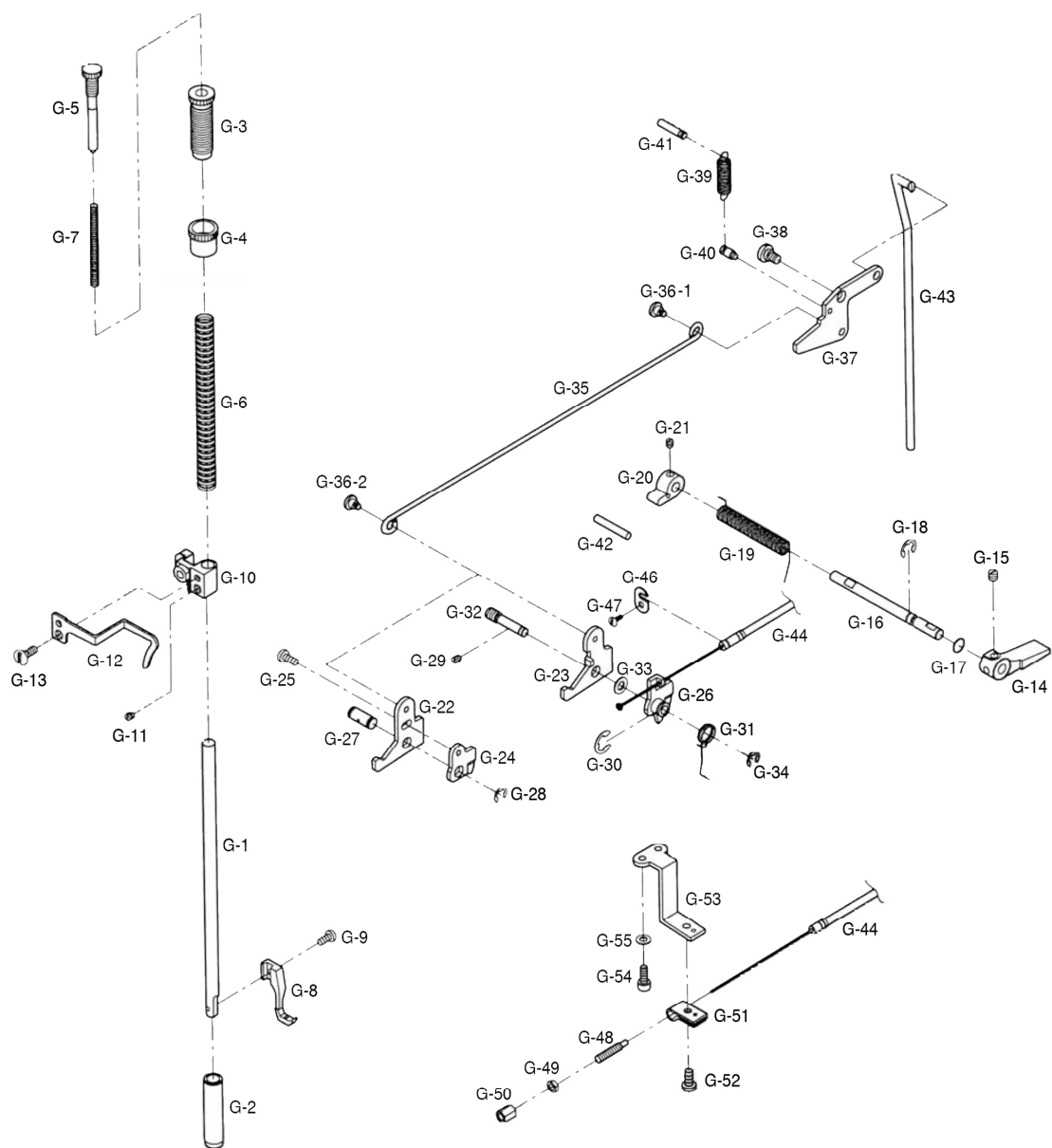

**G 压脚调节部件/Presser Foot&Tension Release Mechanism**

序号 No	公司件号	名称 PartName	零件描述 Description	数量			
				30-3Q	30-4Q	60-3Q	60-4Q
G-43	14212046	抬压脚顶杆	Knee Lifting Bar Stick	1		1	
G-44	14213010	松线钢绳组件	Tension Release Cable Ass'y	1		1	
G-46	14212047	钢绳上固定架	Tension Release Cable	1		1	
G-47	101S11005	钢绳上固定架螺钉	Screw	1		1	
G-48	14226017	钢绳松线调节柱	Connecting Bolt for G-44	1		1	
G-49	N01004	调节柱左锁紧螺母	Nut A for G-44	1		1	
G-50	142S16017	调节柱锁紧螺母	Nut B for G-44	1		1	
G-51	14212048	钢绳下固定架	Tension Release Cable	1		1	
G-52	402S11003	钢绳下固定架螺钉	Screw	1		1	
G-53	14212049	松线钢绳下固定架	Bracket for G-51	1		1	
G-54	421S10012	钢绳下固定架螺钉	Screw for G-53	2		2	
G-55	40928021	钢绳固定架螺钉垫圈	Washer for G-53	2		2	
G-57	14216004	外压脚（三同步）	External pressure foot			1	



H 电控电机部件/Electronic Control Unit

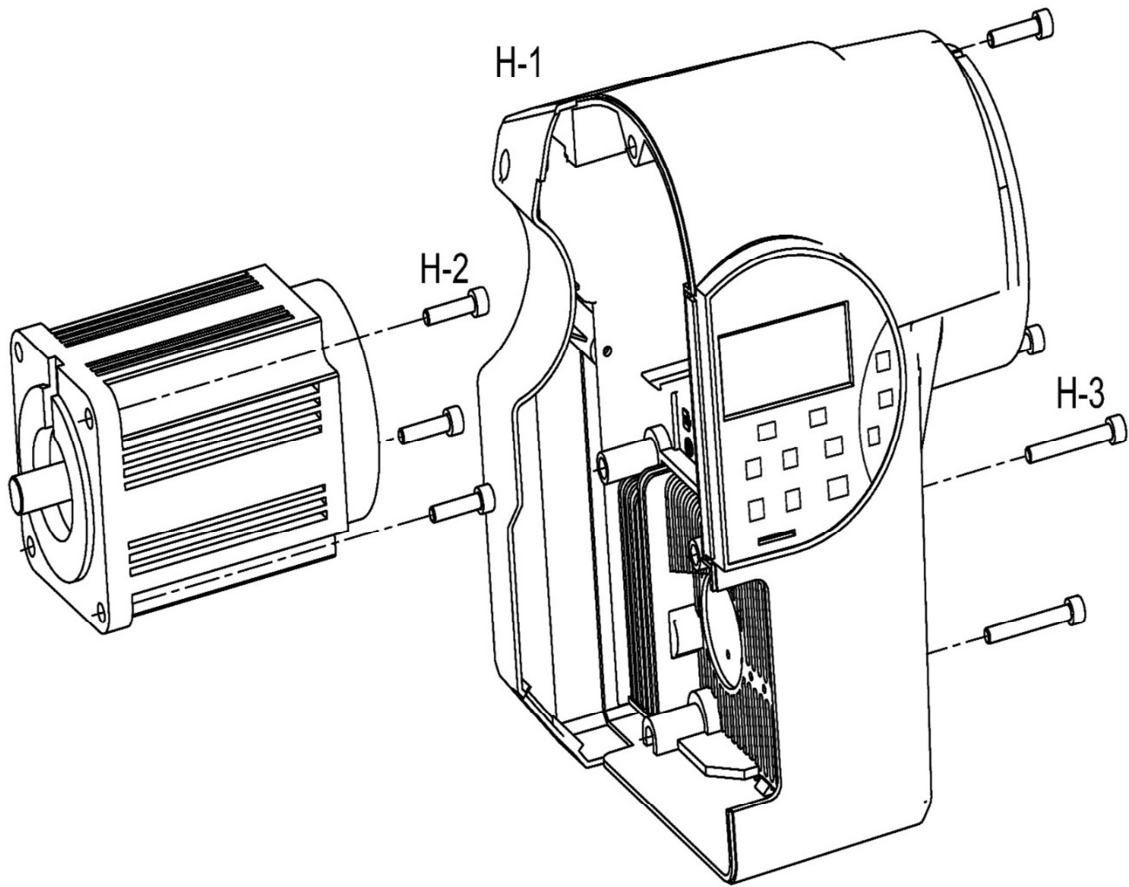

**H 电控电机部件/Electronic Control Unit**

序号 No	公司件号	名称 PartName	零件描述 Description	数量			
				30-3Q	30-4Q	60-3Q	60-4Q
H-1	114233003	2030G 琦星电控(中	Electronic control asm	1		1	
H-2	114S13001	电机安装螺钉	Screw(M5)	4		4	
	W02001	弹簧垫圈	Spring Washer	3		3	
	13628013	电机垫圈	Washer	3		3	
H-3	136S13001	电控安装螺钉	Screw(M5)	3		3	

I 供油部件/Lubrication

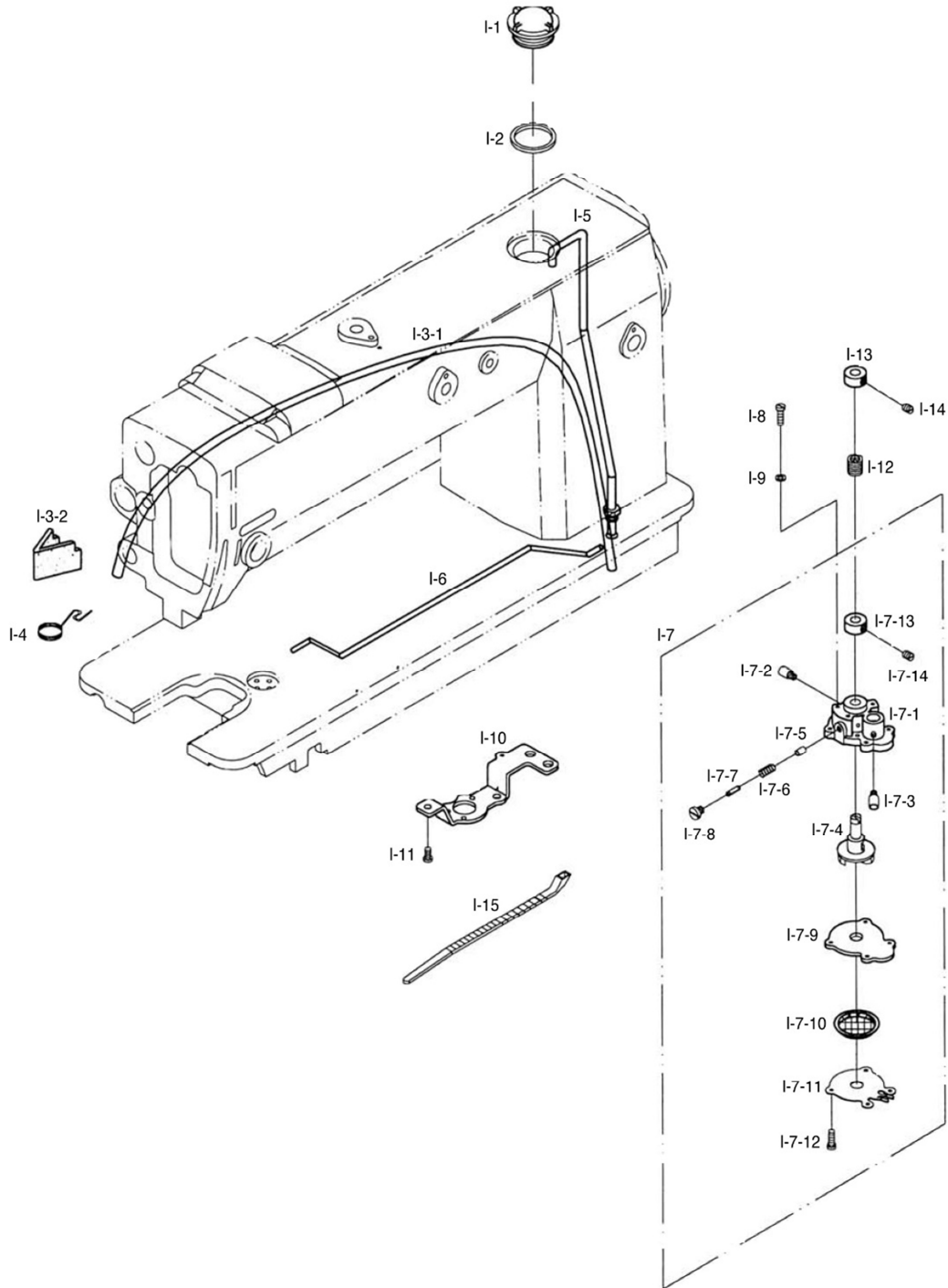

I 供油部件/Lubrication							
序号 No	公司件号	名称 PartName	零件描述 Description	数量			
				30-3Q	30-4Q	60-3Q	60-4Q
I-1	10111004	油窗	Oil Gauge Window	1		1	
I-2	10122019	油窗密封垫 O 型圈	O-Ring	1		1	
I-3-1	12921002	上回油管	Oil Return Tube	1		1	
I-3-2	13523003	上回油管吸油毡	Oil Return Felter	1		1	
I-4	14227018	上回油管吸油毡压	Oil Return Felter Holder	1		1	
I-5	1422100200	上输油管组件	Oil pipe complete for upper	1		1	
I-6	14221003	下输油管	Oil pipe for shaft	1		1	
I-7	1422000100	油泵组件	Oil pump asm	1		1	
I-7-1	14220002	油泵体	Oil pump body	1		1	
I-7-2	14221004	下输油嘴	Nipple for Oil Return Tube	1		1	
I-7-3	14221005	上输油嘴	Nipple for Lower Shaft Oil	1		1	
I-7-4	14220003	油泵叶轮	Impeller	1		1	
I-7-5	14220004	柱塞	Piston	1		1	
I-7-6	14227019	柱塞弹簧	Piston Spring	1		1	
I-7-7	14226019	柱塞弹簧销	Piston Spring Pin	1		1	
I-7-8	142S11061	柱塞弹簧螺钉	Piston Spring Pin Screw	1		1	
I-7-9	14212055	油泵体盖板	Oil Pump Cover	1		1	
I-7-10	14212056	油泵过滤网	Oil Pump Cap	1		1	
I-7-11	14212057	油泵磁铁夹	Magnetic Holder	1		1	
I-7-12	402S11010	油泵体盖板螺钉	Screw(9/64" n=40)	4		4	
I-7-13	14208011	油泵体上紧圈	Collar for Impeller Shaft	1		1	
I-7-14	413S14006	油泵体上紧圈螺钉	Screw(M4)	2		2	
I-7-15	14202030	油泵叶轮安装轴	Impeller Axis	1		1	
I-8	206S11002	油泵体连接螺钉	Screw(9/64" n=40)	3		3	
I-9	W02002	油泵体连接螺钉垫	Oil Pump Body Washer	3		3	
I-10	14212059	油泵体连接支架	Oil Pump Bracket	1		1	
I-11	409S11003	油泵体连接支架螺	Screw(3/16" n=28)	1		1	
I-12	14227020	竖轴弹簧	Oil Pump Connecting Spring	1		1	
I-13	14208012	竖轴紧圈	Oil Pump Connecting Collar	1		1	
I-14	125S15003	竖轴紧圈螺钉	Screw(11/64" n=40)	2		2	
I-15	40111005	油管定位扎带	Nylon Clib	2		2	

K 自动抬压脚部件/Automatic presser Foot Parts

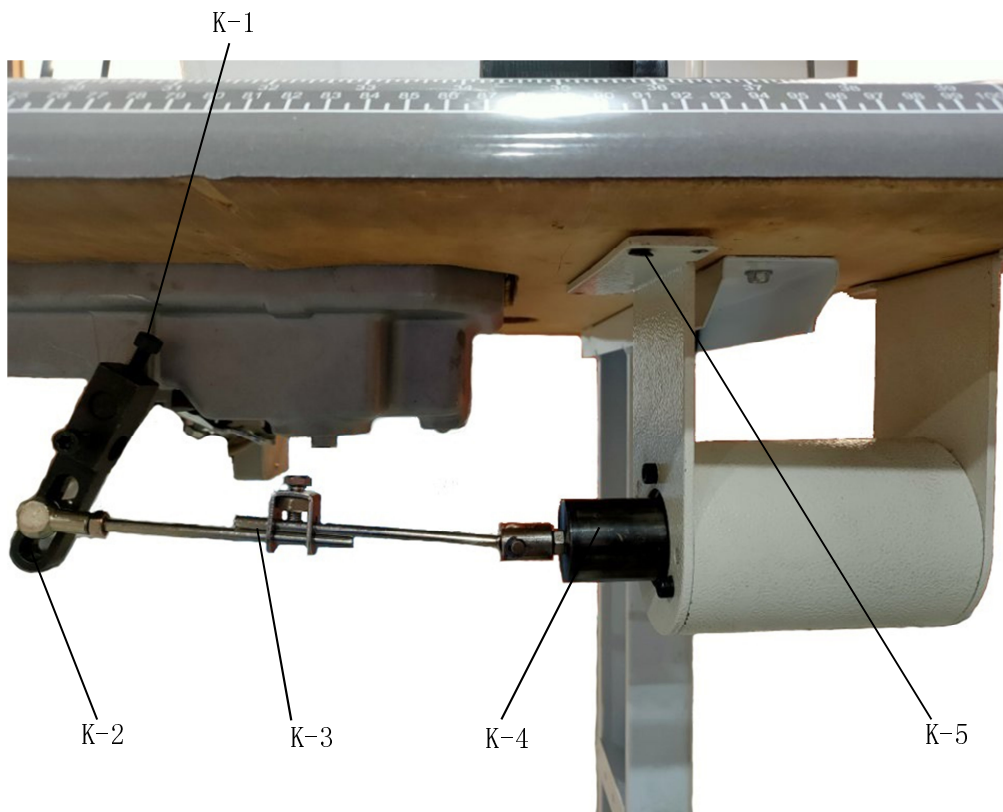

**K 自动抬压脚部件/Automatic presser Foot Parts**

序号 No	公司件号	名称 PartName	零件描述 Description	数量			
				30-3Q	30-4Q	60-3Q	60-4Q
K-1	207S11026	螺钉 M6×16	Screw M6x16		1		1
K-2	14204024	抬压脚曲柄	Presser Foot Crank		1		1
K-3	1423103600	拉杆组件	Lever Assembly		1		1
K-4	1423001200	抬压脚电磁铁组件	Pressure-carryingfoot		1		1
K-5	101S30014	绕线器木螺钉 M4×20	Screw M4x20		8		8

K 自动抬压脚部件/Automatic presser Foot Parts

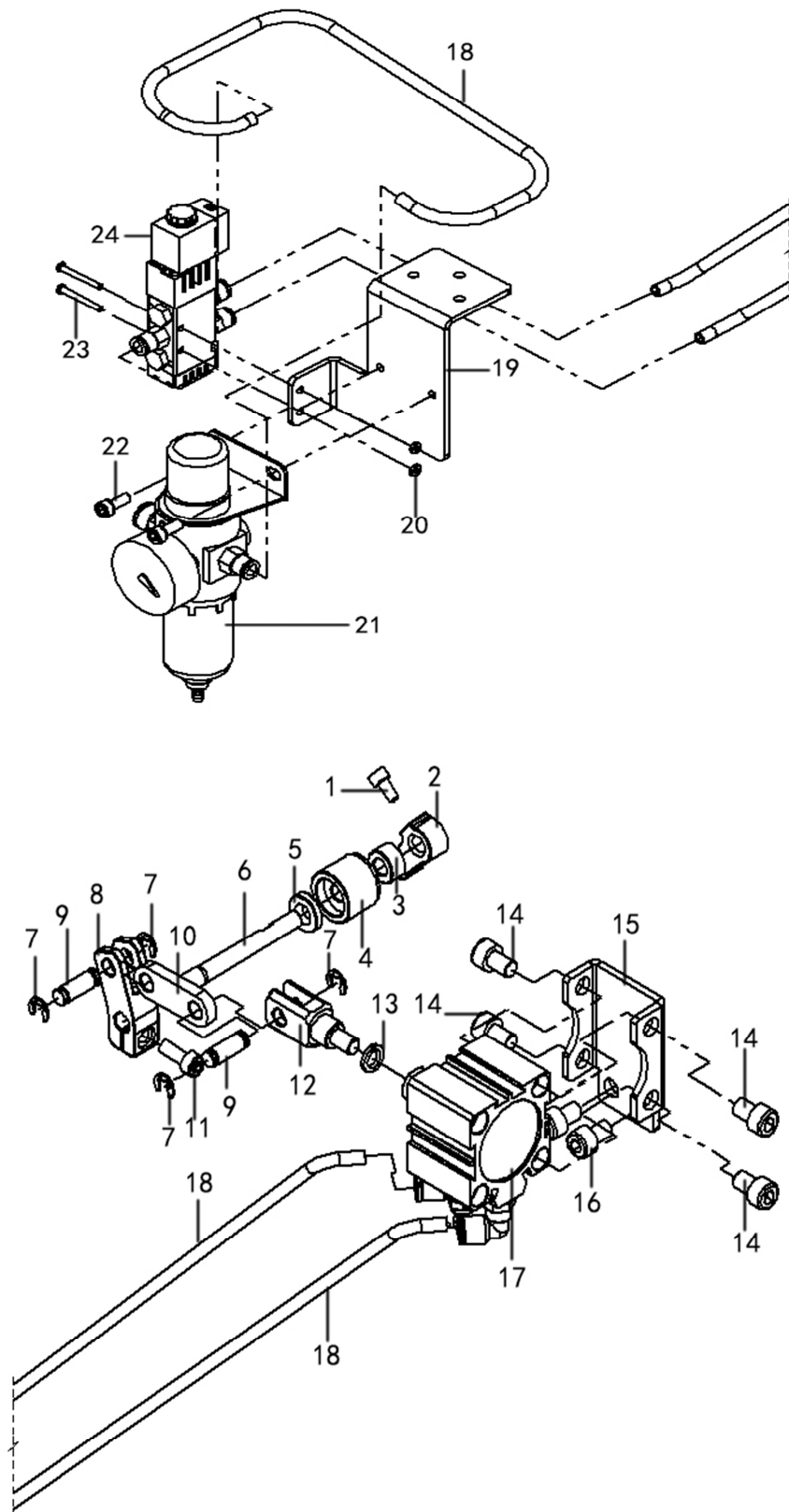

### K 气动抬压脚部件/Pneumatic presser Foot Parts

序号 No	公司件号	名称 PartName	零件描述 Description	数量			
				30-3Q	30-4Q	60-3Q	60-4Q
K-1	413S13023	螺钉 M6×12	Screw M6x12		1		1
K-2	114204002	气动抬压脚曲柄	Presser Foot Crank		1		1
K-3	114208001	挡圈	Retaining ring		1		1
K-4	114203001	气动抬压脚轴套	Pressure-carrying foot		1		1
K-5	10122015	油封	Oil seal		1		1
K-6	114202001	气动抬压脚轴	Lifting foot shaft		1		1
K-7	H05013	开口挡圈 6	Open retaining ring 6		4		4
K-8	114204001	气动抬压脚连杆	Lifting foot connecting rod		1		1
K-9	114226002	连接销	Connection pin		2		2
K-10	114205001	气缸接头连杆	Cylinder joint connecting rod		1		1
K-11	207S11026	螺钉 M6×16	Screw M6x16		1		1
K-12	114236003	气缸接头	Cylinder joint		1		1
K-13	W02023	GB/T 93 标准型弹簧	Spring washer φ8		1		1
K-14	S05007	螺钉 M8×20	Screw M8x20		4		4
K-15	114212002	气缸安装板	Cylinder mounting plate		1		1
K-16	S05079	螺钉 M8×12	Screw M8x12		2		2
K-17	1142450010	抬压脚气缸	Lifting foot cylinder assembly		1		1
K-18		气管	Trachea		3		3
K-19	142312006	气压阀安装板	Valve mounting plate		1		1
K-20	N01013	GB/T6170-1986 螺母	Nut M3		2		2
K-21	114245004	气源处理元件	Gas source processing		1		1
K-22	S05005	螺钉 M5×12	Screw M5x12		2		2
K-23	407S04053	十字半圆头螺钉	Screw M3x25		2		2
K-24	114245005	电磁阀	The electromagnetic valve		1		1