

Jamato®

INDUSTRIAL SEWING MACHINE

ILLUSTRATED SPARE PARTS LIST
FOR
SUPER HIGH SPEED
OVERLOCK MACHINE

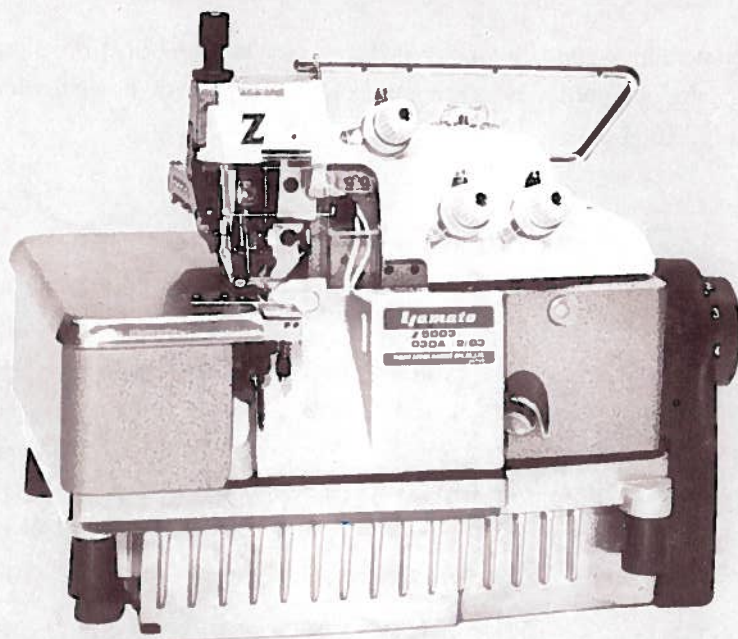

MODELS & DEVICES

Z5003	Z5000	Z5006	Z5016	Z5020
Z5021	Z5025	Z5026	Z5027	Z5037
Z5045	Z5046	Z5056	Z5057	

— C —	— K2 —	— KT2 —	— KR2 —	— MT2 —	— MU4 —	— MU5 —
— CH20 —	— BT13 —	— B3 —	— SP —	— HR —		

Guideline to utilize Parts Book for Class Z5000

Quickly and without mistake, you will obtain the right object in your hand by means of Parts Book which shows name and numbers in contrast with their illustrations by each mechanism, when certain part must be replaced or modified.

Parts for Z5003-03DF (04, 05, 06), standard model, are shown from page 1 to 14, and those for Sub-models, Attachments and Extra Parts separately supplied from page 15.

Note: * Parts for Sub-models are shown only by those different from standard model.
* Parts in common with standard model are not shown except those of virtual lines (two-dots chain lines).

For your convenience, Gauge Parts are shown in "List of Main Spare Part", page 60, 61 and 62.

By Part Number in "INDEX" from page 63, you can easily check its shape and/or setting spot on machines. Your purchase order must be placed by its own part number!

Additionally, kindly understand that there may be some differences in numbers or shapes of parts owing to our constant improvements, because the Parts Book has been made on the basis of production in January, 1984.

〈パーツブックご利用に際して〉

この度は、ヤマトZ5000クラスのみシンをお買上げ頂き、誠にありがとうございます。

このパーツブックは修理交換用の部品や他のモデルに改造する場合等に目的の部品をいち早く捜して頂くため、分かり易く機構別にイラストと表を対比して掲載しております。

すなわち、Z5003-03DF (04, 05, 06) を基本モデルとし、1ページから14ページまでを基本モデル、15ページからサブモデル、附帯装置及び特注部品の部品を掲載しております。このサブモデルの部品構成は、基本モデルと異なる部品のみを掲載しており、仮想線(2点鎖線)及び無掲載の部品は基本モデルと共通使用のものでありますから、この点ご注意ください。

ゲージパーツ関係は60, 61, 62ページに主要部品リストとして分かり易く表にしてありますので合わせてご利用ください。

また、部品番号で部品の形状や、ミシンのどの部分に組込まれている部品か等をお調べの場合は63ページからの索引 (INDEX) にて簡単に引き出せます。

部品をお求めの際は部品番号でお間違いのないようお願いいたします。

なお、このパーツブックは1984年1月現在製造中のミシンを基本に作成しております。品質性能に関しましては絶えず研究し、日々改良を加えておりますので部品番号及び形状等が異なる場合がありますからご了承ください。

1

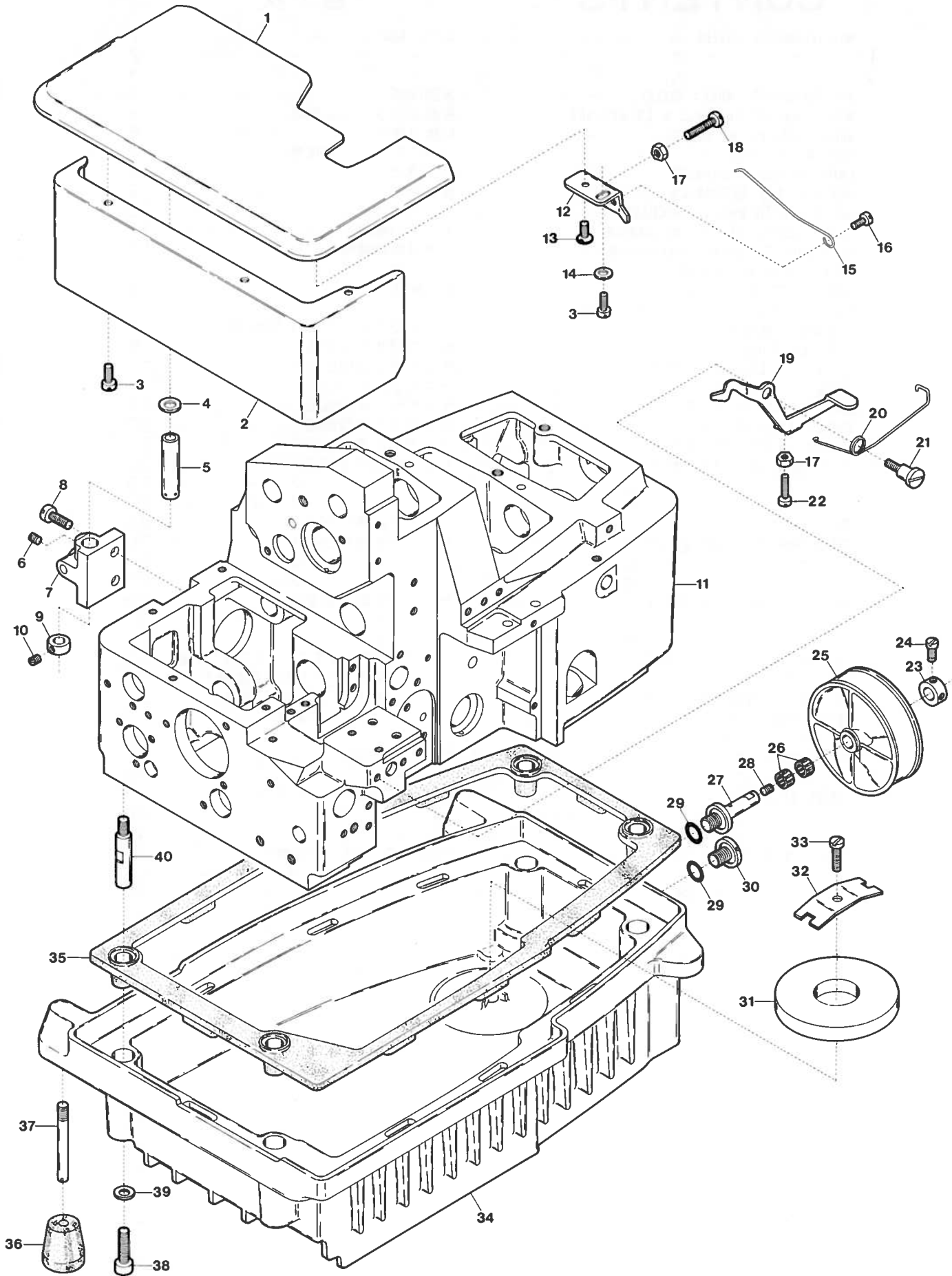

Ref. No.	Parts No.	Description	品名	Amt. Req.
1	21727	Cloth Plate	クロスプレート	1
2	20034	Cloth Plate (Lower)	クロスプレート(下)	1
3	4358	Screw for 20034, 20035	止ネジ	4
4	528	Washer for 21727	ワッシャ	1
5	34637	Cloth Plate Eccentric Bushing	クロスプレートエキセンブッシュ	1
6	7650	Screw for 34637	止ネジ	2
7	21725	Cloth Plate Hinge	クロスプレートヒンジ	1
8	5089	Screw for 21725	クロスプレートヒンジ止ネジ	2
9	34505	Cloth Plate Hinge Pin Collar	クロスプレートヒンジピンカラー	1
10	1459	Screw for 34505	ヒンジピンカラー止ネジ	2
11	21888	Machine Frame	フレーム	1
12	20035	Cloth Plate Latch Bracket	クロスプレートラッチ	1
13	9143	Screw for 20035	クロスプレートラッチ止ネジ	1
14	532	Washer for 20035	ワッシャ	1
15	34510	Cloth Plate Spring	クロスプレート戻シバネ	1
16	7006	Screw for 34510	クロスプレート戻シバネ止ネジ	1
17	335	Stopper Nut for 21727, 20036	ナット	2
18	1170	Stopper Screw for 21727	クロスプレートストップバネ止ネジ	1
19	20036	Cloth Plate Latch	クロスプレートフック	1
20	20038	Cloth Plate Latch Spring	クロスプレートストップバネ	1
21	4117	Screw for 20036	クロスプレートフック止ネジ	1
22	1132	Screw for 20036	クロスプレートフック調節ネジ	1
23	30228	Oil Cooling Fan Shaft Collar	ファンシャフトカラー	1
24	9604	Screw for 30228	ファンシャフトカラー止ネジ	2
25	20054	Oil Cooling Fan	ファン	1
26	77366	Roller Bearing	ニードルベアリング	2
27	20056	Oil Cooling Fan Shaft	ファンシャフト	1
28	3646	Screw for 20056	ファンシャフト止ネジ	1
29	32421	O-Ring	Oリング	2
30	5076	Drain Hole Screw	油受け油抜キネジ	1
31	35149	Oil Reservoir Magnet	油受けマグネット	1
32	35150	Oil Reservoir Magnet Holder	油受けマグネット押工	1
33	9150	Screw for 35150	油受けマグネット押工止ネジ	1
34	20048	Oil Reservoir	油受け	1
35	20049	Oil Reservoir Gasket	油受けパッキン	1
36	20053	Oil Reservoir Rubber Cushion	防振ゴム	4
37	6816	Screw for 20053	防振ゴム止ネジ	4
38	5108	Screw for 20048	油受け止ネジ	4
39	184	Washer for 20048	ワッシャ	4
40	20080	Oil Reservoir Positioning Bar	油受け固定棒	4

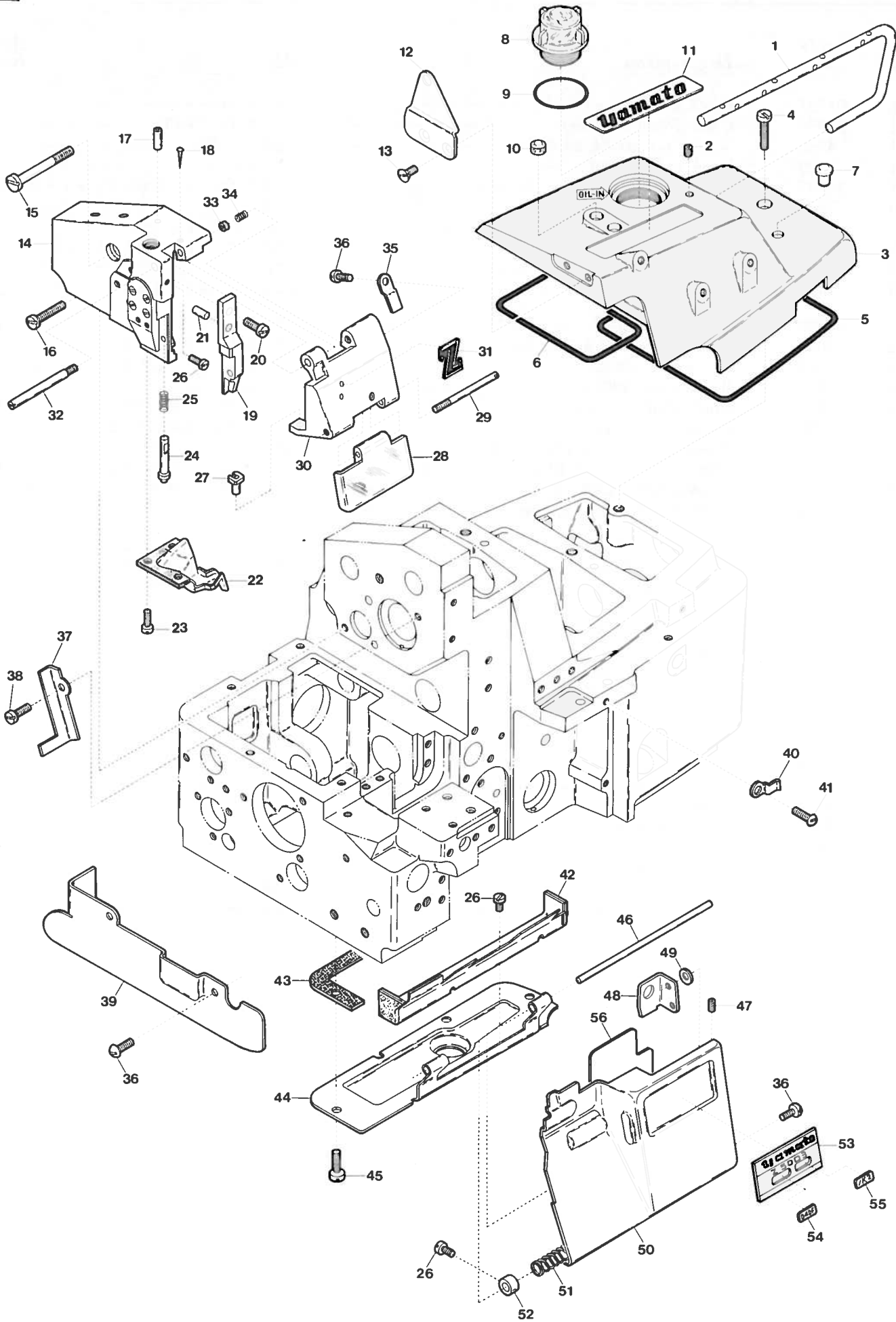

Ref. No.	Parts No.	Description	品名	Amt. Req.
1	24040	Thread Lead Bar	糸道棒	1
2	3632	Screw for 24040	糸道棒止ネジ	1
3	24074	Top Cover	上カバー	1
4	5083	Screw for 24074	上カバー止ネジ	2
5	20003	Top Cover Gasket (Right)	上カバーパッキン(右)	1
6	24075	Top Cover Gasket (Left)	上カバーパッキン(左)	1
7	32612	Top Cover Packing Piece (Small)	上カバー詰栓(小)	1
8	20004	Oil Cap	オイルキャップ	1
9	20005	Oil Cap Seal	オイルキャップOリング	1
10	24076	Top Cover Packing Piece (Large)	上カバー詰栓(大)	1
11	916	Brand Name Plate	銘板	1
12	23193	Thread Lead Bar Holder	糸道棒振レ止メ	1
13	5343	Screw for 23193	糸道棒振レ止メ止ネジ	2
14	22760	Side Cover Unit	側面カバー(組)	1
15	4122	Screw for 22760	側面カバー(組)止ネジ	1
16	4441	Screw for 22760	側面カバー(組)止ネジ	1
17	22370	Needle Driving Slider Oiling Pipe	針案内棒給油パイプ	1
18	726	Rivet for 22763	止メ鉄	1
19	21188	Dust Proof-off Block	防塵ブロック	1
20	4312	Screw for 21188	防塵ブロック止ネジ	2
21	652	Pin for 21188	ピン	1
22	22766	Oil Defender	針案内油受ケ	1
23	5133	Screw for 22766	針案内油受ケ止ネジ	3
24	22764	Needle Thread Cover Latch Pin	針糸カバーフックピン	1
25	22261	Needle Thread Cover Latch Spring	針糸カバーフックピンバネ	1
26	1228	Screw for 22764, 22758, 33081	止ネジ	4
27	22259	Needle Thread Cover Latch Pin Stopper	針糸カバーフックピン受ケ座	1
28	22765	Safety Plate	アイガード	1
29	20659	Safety Plate Hinge Pin	アイガードヒンジピン	1
30	22763	Needle Thread Cover	針糸カバー	1
31	1016	"Z" Mark	Zマーク	1
32	22260	Needle Thread Cover Pin	針糸カバーピン	1
33	396	Stop Rubber for 22371	ゴム座	1
34	22371	Needle Thread Cover Stop Spring	針糸カバー圧着バネ	1
35	20660	Safety Plate Latch Spring	アイガードヒンジバネ	1
36	1330	Screw for 20660, 21728, 22768	止ネジ	4
37	20079	Needle Driving Slider Cover (Rear)	針案内カバー(後)	1
38	9604	Screw for 20079	針案内カバー(後)止ネジ	1
39	21728	Dust-proof Cover (Left)	防塵カバー(左)	1
40	20014	Front Cover Latch Spring	前カバーラッチバネ	1
41	9121	Screw for 20014	前カバーラッチバネ止ネジ	1
42	22758	Dust-proof Cover (Lower)	防塵カバー(下)	1
43	24134	Front Cover Hinge Gasket	前カバーヒンジパッキン	1
44	20015	Front Cover Hinge	前カバーヒンジ	1
45	4440	Screw for 20015	前カバーヒンジ止ネジ	4
46	20016	Front Cover Hinge Pin	前カバーヒンジピン	1
47	3637	Screw for 20016	前カバーヒンジピン止ネジ	2
48	22768	Front Cover Hook	前カバーフック	1
49	538	Washer for 22768	ワッシャー	1
50	22746	Front Cover	前カバー	1
51	20017	Front Cover Hinge Spring	前カバーヒンジバネ	1
52	33081	Front Cover Hinge Spring Collar	前カバーヒンジバネカラー	1
53	—	Model Plate (See Page 62)	型式板(62ページ参照)	1
54	—	Gauge Indicate Plate (See Page 62)	ゲージ記号板(62ページ参照)	1
55	—	Device Indicate Plate (See Page 62)	デバイス記号板(62ページ参照)	1
56	—	Threading Chart (Right) (See Page 62)	糸通シ図(62ページ参照)	1

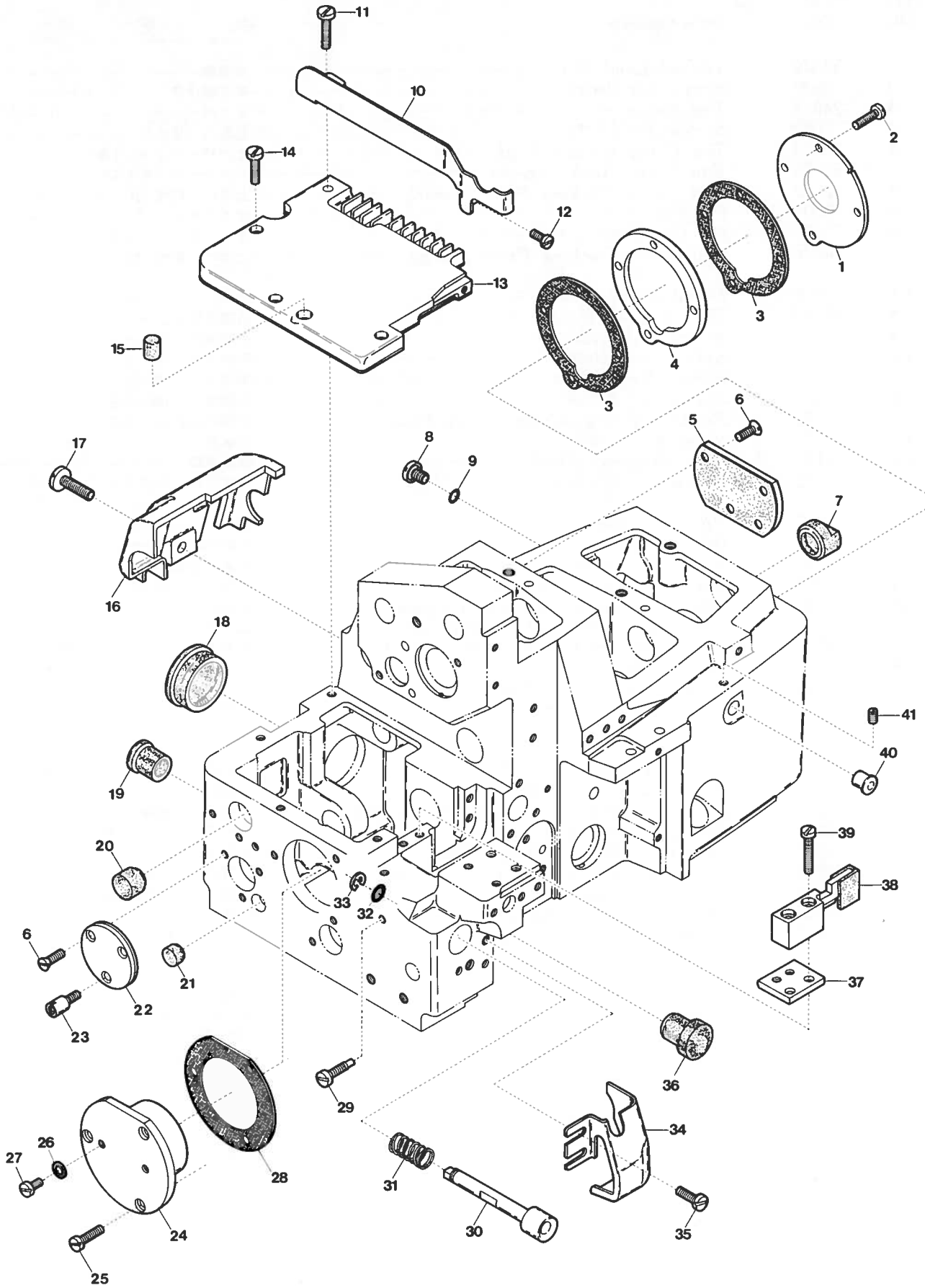

Ref. No.	Parts No.	Description	品名	Amt. Req.
1	24093	Ball Bearing Holder	ベアリング押工	1
2	5043	Screw for 24093	ベアリング押工止ネジ	4
3	24092	Ball Bearing Spacer Gasket	ベアリングスパーサパッキン	2
4	24091	Ball Bearing Spacer	ベアリングスパーサ	1
5	20060	Needle Driving Shaft End Cap	針振り軸蓋	1
6	5345	Screw for 20060, 33013	止ネジ	6
7	20061	Upper Knife Driving Shaft Oil Shield	上メス軸詰栓	1
8	5078	Screw for Machine Frame	フレームネジ蓋	1
9	20538	Seal for 5078	オリング	1
10	20043	Fabric Guide	クロスプレート布案内	1
11	4441	Screw for 20043	クロスプレート布案内止ネジ	1
12	4314	Screw for 20043	クロスプレート布案内止ネジ	1
13	21737	Feed Mechanism Cover	送り台カバー	1
14	4437	Screw for 21737	送り台カバー止ネジ	3
15	20072	Rubber Cushion	埋メ座(中)	1
16	24073	Rear Cover	後カバー	1
17	4635	Screw for 24073	後カバー止ネジ	1
18	20047	Feed Adjusting Window Cap	送り調節窓蓋	1
19	20046	Double Chaining Looper Driving Shaft Oil Shield	二重環ルーバ軸詰栓	1
20	20052	Eccentric Pin Oil Shield	エキセンピン詰栓	1
21	20051	Feed Driving Connecting Rod Oil Shield	送りロッドピン詰栓	1
22	33013	Feed Driving Shaft End Cap	送り軸蓋	1
23	4145	Screw for 33013	送り軸蓋止ネジ	1
24	21021	Ball Bearing Housing	ボールベアリングハウジング	1
25	4406	Screw for 21021	ボールベアリングハウジング止ネジ	3
26	550	Seal for 21021	パッキン	2
27	9944	Screw for 21021	ネジ蓋	2
28	20161	Ball Bearing Housing Gasket	ハウジングパッキン	1
29	5094	Screw for 20470	プッシュボタンガイドネジ	1
30	20470	Feed Regulating Pushbutton	プッシュボタン	1
31	33131	Feed Regulating Pushbutton Spring	プッシュボタンバネ	1
32	20472	Seal for 20470	オリング	1
33	33024	Retaining Ring for 20470	ストップリング	1
34	22835	Front Cover (Left)	前カバー(左)	1
35	9853	Screw for 22835	前カバー(左)止ネジ	2
36	21006	Rubber Packing Piece (Large)	フレーム詰栓(大)	1
37	20228	Stitch Plate Stay Spacer	針板支エスパーサ	1
38	21731	Stitch Plate Stay	針板支工	1
39	9931	Screw for 21731	針板支工止ネジ	2
40	32612	Packing Pice	詰栓	1
41	4435	Screw for 32612	詰栓止ネジ	1

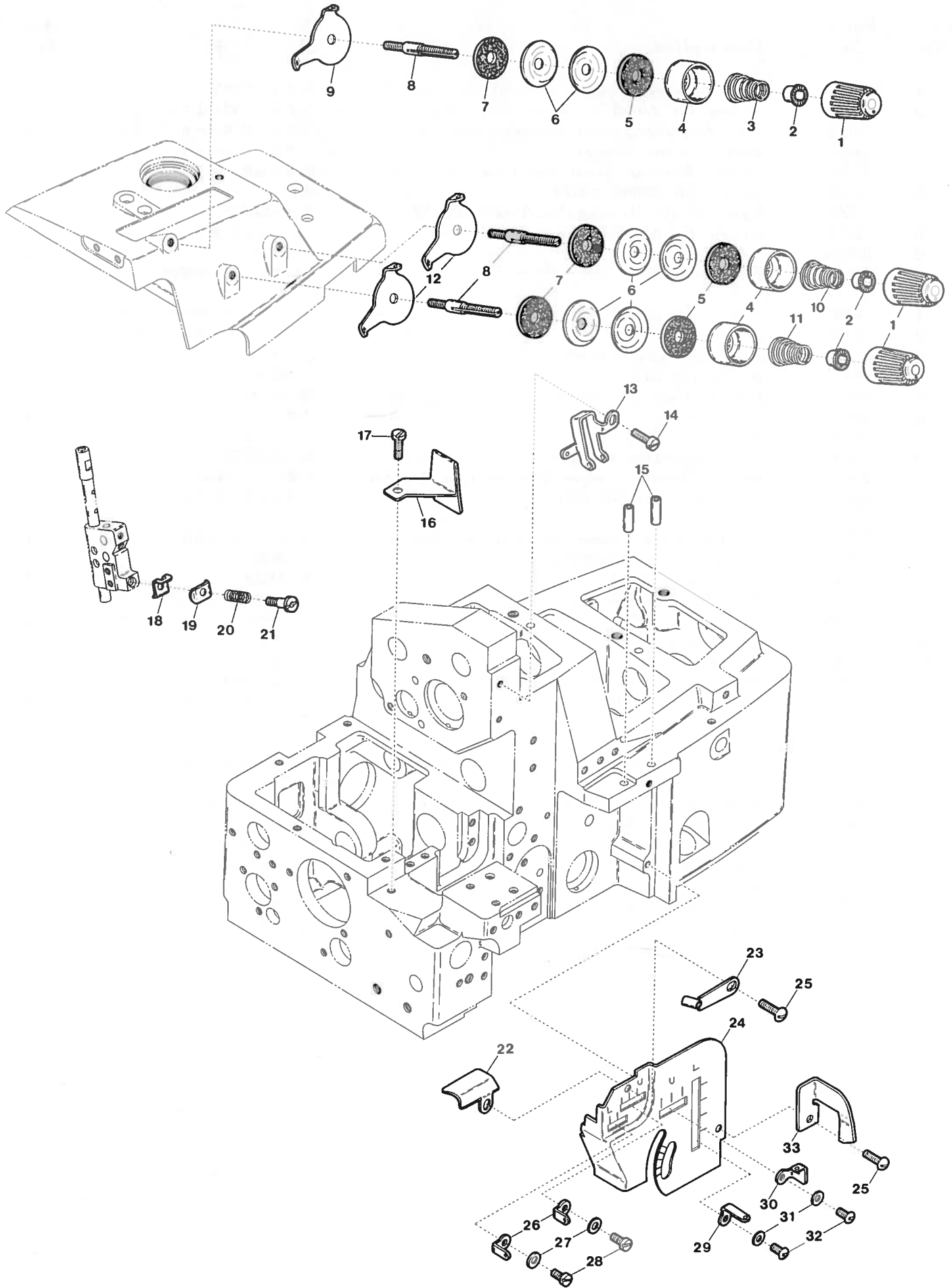

Ref. No.	Parts No.	Description	品名	Amt. Req.
1	20104	Thread Tension Spring Cap	糸調子バネキャップ	3
2	33890	Tension Spring Bushing	糸調子ナット回り止メ	3
3	20132	Needle Thread Tension Spring	糸調子バネ	1
4	20118	Thread Tension Spring Retainer	糸調子バネキャップ(下)	3
5	178	Felt for 31111	フェルト	3
6	31111	Tension Disc	糸調子皿	6
7	177	Felt for 31111	フェルト	3
8	7904	Tension Post (Long)	糸調子棒(長)	3
9	21001	Tension Disc Eyelet for Needle Thread	針糸調子台糸道	1
10	20102	Lower Looper Thread Tension Spring	下ルーバ糸調子バネ	1
11	20103	Upper Looper Thread Tension Spring	上ルーバ糸調子バネ	1
12	20101	Tension Disc Eyelet for Looper Thread	ルーバ糸調子台糸道	2
13	23466	Needle Thread Eyelet	針糸道	1
14	4353	Screw for 23466	針糸道止ネジ	1
15	22215	Looper Thread Tube	糸道パイプ	2
16	20667	Lower Looper Cover	下ルーバカバー	1
17	9853	Screw for 20667	下ルーバカバー止ネジ	1
18	21855	Thread Retainer Bracket	小調子台	1
19	21856	Thread Retainer Plate	小調子皿	1
20	20131	Thread Retainer Spring	小調子皿バネ	1
21	4137	Screw for 20131	小調子皿バネ止ネジ	1
22	21726	Looper Bar Oil Defender	ルーバ棒油除ケ	1
23	21720	Upper Looper Thread Pipe	上ルーバ糸道パイプ	1
24	21713	Looper Thread Eyelet Support	ルーバ糸道取付板	1
25	1326	Screw for 21713	ルーバ糸道取付板止ネジ	2
26	21714	Looper Thread Eyelet (Left)	ルーバ糸道(左)	2
27	444	Washer for 21714	ワッシャ	2
28	1227	Screw for 21714	ルーバ糸道(左)止ネジ	2
29	20110	Lower Looper Thread Eyelet	下ルーバ糸道	1
30	20108	Upper Looper Thread Eyelet (Right)	上ルーバ糸道(右)	1
31	532	Washer for 20110, 20108	ワッシャ	2
32	1330	Screw for 20110, 20108	ルーバ糸道止ネジ	2
33	22769	Front Cover Hook Guide	前カバーフックガイド	1

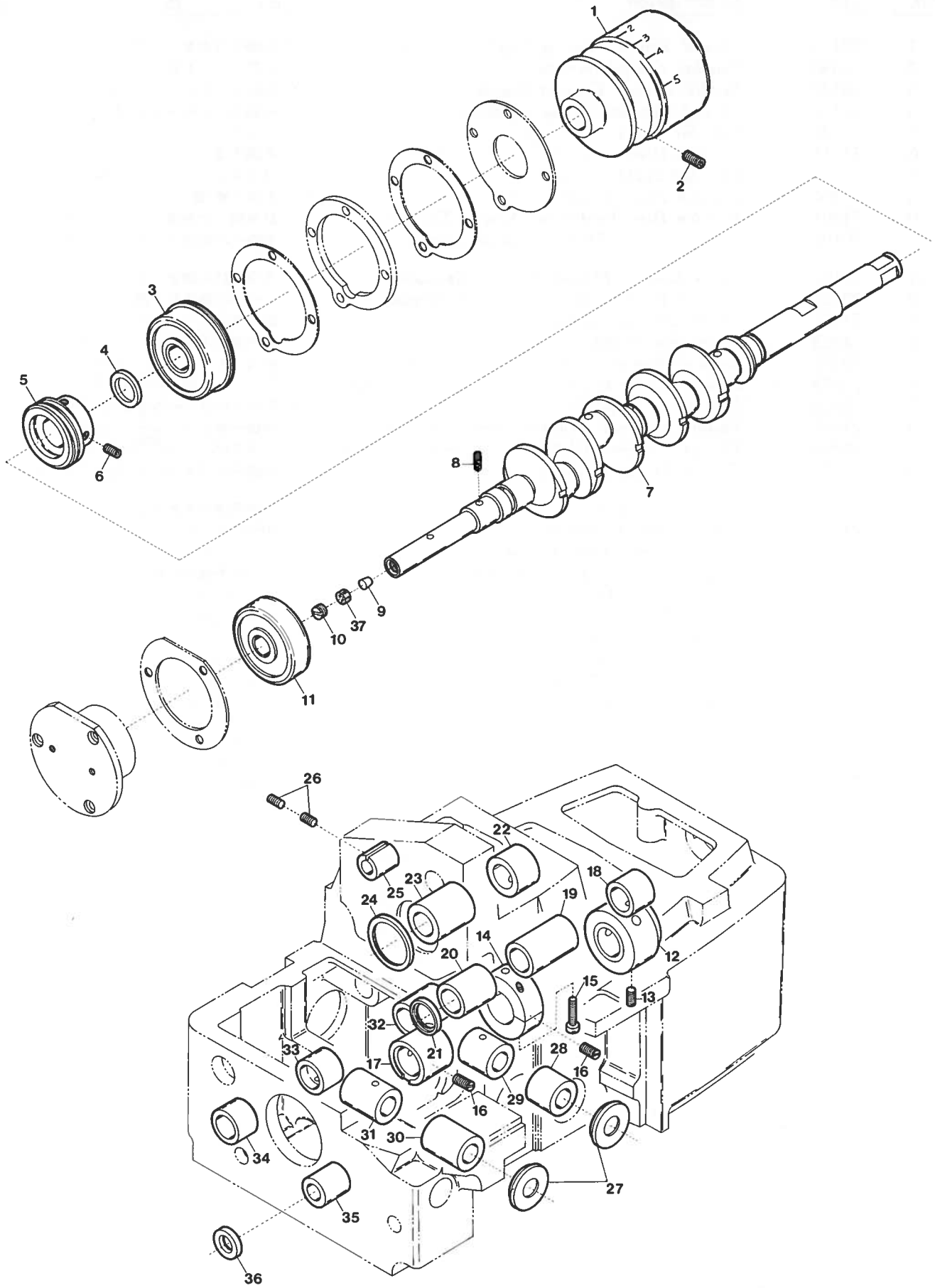

Ref. No.	Parts No.	Description	品 名	Amt. Req.
1	22591	Pulley	プーリ	1
2	4123	Screw for 22591	プーリ止ネジ	2
3	20154	Crankshaft Ball Bearing (Large)	ボールベアリング(大)	1
4	32779	Crankshaft Ball Bearing Retaining Washer	ベアリング位置決めリング	1
5	20155	Oil Pump Driving Worm	ウォーム	1
6	4108	Screw for 20155	ウォーム止ネジ	2
7	22580	Crankshaft	クランクシャフト	1
8	397	Oil Wick for 22580	油芯	1
9	740	Seal Plug for 22580	詰栓	1
10	7645	Screw for 22580	クランクシャフト詰ネジ	1
11	20159	Crankshaft Ball Bearing (Small)	ボールベアリング(小)	1
12	20156	Crankshaft Bushing (Right)	クランクシャフトブッシュ(右)	1
13	3434	Screw for 20156	クランクシャフトブッシュ(右)止ネジ	1
14	20157	Crankshaft Bushing (Center)	クランクシャフトブッシュ(中)	1
15	1170	Screw for 20157	クランクシャフトブッシュ(中)止ネジ	2
16	3654	Screw for 20157, 20158	止ネジ	2
17	20158	Crankshaft Bushing (Left)	クランクシャフトブッシュ(左)	1
18	20485	Upper Knife Driving Shaft Bushing (Right)	上メス軸ブッシュ(右)	1
19	20484	Upper Knife Driving Shaft Bushing (Center)	上メス軸ブッシュ(中)	1
20	20483	Upper Knife Driving Shaft Bushing (Left)	上メス軸ブッシュ(左)	1
21	32684	Upper Knife Driving Shaft Oil Seal	上メス軸オイルシール	1
22	20185	Needle Driving Shaft Bushing (Right)	針振り軸ブッシュ(右)	1
23	20186	Needle Driving Shaft Bushing (Left)	針振り軸ブッシュ(左)	1
24	20187	Needle Driving Shaft Oil Seal	針振り軸油切りリング	1
25	21889	Needle Driving Lever Link Shaft Bushing	針振りリンク軸ブッシュ	1
26	3635	Screw for 21889	針振りリンク軸ブッシュ止ネジ	2
27	20334	Looper Driving Shaft Oil Seal	ルーバ軸オイルシール	2
28	21721	Upper Looper Driving Shaft Bushing (Front)	上ルーバ軸ブッシュ(前)	1
29	20316	Upper Looper Driving Shaft Bushing (Rear)	上ルーバ軸ブッシュ(後)	1
30	20344	Lower Looper Driving Shaft Bushing (Front)	下ルーバ軸ブッシュ(前)	1
31	20345	Lower Looper Driving Shaft Bushing (Rear)	下ルーバ軸ブッシュ(後)	1
32	20412	Feed Bar Driving Shaft Bushing (Right)	送り軸ブッシュ(右)	1
33	20411	Feed Bar Driving Shaft Bushing (Center)	送り軸ブッシュ(中)	1
34	20410	Feed Bar Driving Shaft Bushing (Left)	送り軸ブッシュ(左)	1
35	95134	Differential Feed Control Lever Shaft Bushing	送り調節レバー軸ブッシュ	1
36	30291	Differential Feed Control Lever Shaft Oil Seal	送り調節レバー軸オイルシール	1
37	629	Rubber Seal for 22580	詰栓(ゴム)	1

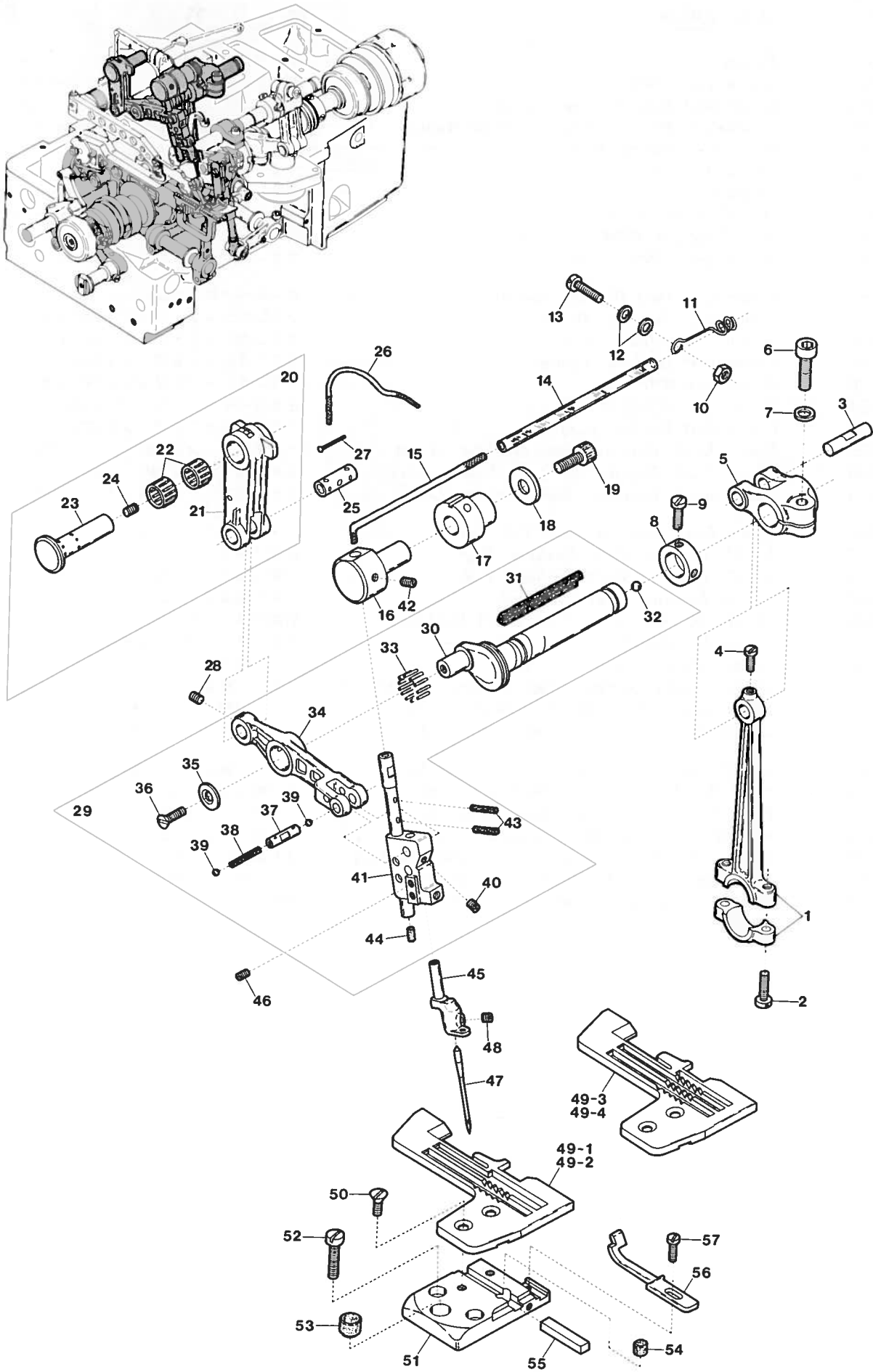

Ref. No.	Parts No.	Description	品名	Amt. Req.
1	20180	Needle Driving Connecting Rod	針ロッド	1
2	5070	Screw for 20180	針ロッド止ネジ	2
3	32921	Connecting Rod Pin	針ロッドピン	1
4	9508	Screw for 32921	針ロッドピン止ネジ	1
5	21722	Needle Driving Shaft Lever	針振り軸腕	1
6	5520	Screw for 21722	針振り軸腕止ネジ	1
7	520	Washer for 21722	ワッシャ	1
8	32646	Needle Driving Shaft Collar	針振り軸カラー	1
9	9604	Screw for 32646	針振り軸カラー止ネジ	2
10	334	Nut for 21724	ナット	1
11	21724	Needle Guide Bar Oil Wick Stay	針案内棒油芯支エ	1
12	550	Packing Ring for 21724	パッキン	2
13	4441	Screw for 21724	針案内棒油芯支エ止ネジ	1
14	20550	Oil Wick Tube (4×4.8×100mm)	油芯保護パイプ	1
15	194	Oil Wick for 20198 (300mm)	油芯	1
16	20198	Needle Guide Bar Holder	針案内棒ホルダ	1
17	20199	Needle Guide Bar Holder Bushing	針案内ホルダブッシュ	1
18	183	Washer for 20199	ワッシャ	1
19	5108	Screw for 20199	針案内棒ホルダブッシュ止ネジ	1
20	20237	Needle Driving Lever Link, Complete Set	針振りリンク(組)	1
21	20192	Needle Driving Lever Link	針振りリンク	1
22	20189	Roller Bearing for 20193	ニードルベアリング	2
23	20193	Needle Driving Lever Link Shaft	針振りリンク軸	1
24	3434	Screw for 20193	針振りリンク軸止ネジ	1
25	20191	Needle Driving Lever Link Pin	針振りリンクピン	1
26	195	Oil Wick for 20192 (175mm)	油芯	1
27	755	Pin for Oil Wick	油芯止メピン	1
28	3638	Screw for 20191	針振りリンクピン止ネジ	1
29	23461	Needle Driving Shaft, Complete Set	針振り軸(組)	1
30	22845	Needle Driving Shaft	針振り軸	1
31	174	Oil Wick for 22845	油芯	1
32	639	Seal Plug for 22845	詰栓	1
33	22616	Needle Roller	ニードルローラ	20
34	23460	Needle Driving Lever	針振りレバー	1
35	20190	Needle Driving Lever Retainer	針振りレバー押エ	1
36	7128	Screw for 20190	針振りレバー押エ止ネジ	1
37	20195	Needle Driving Lever Pin	針振りレバーピン	1
38	199	Oil Wick for 20195	油芯	1
39	636	Seal Plug for 20195	詰栓	2
40	1459	Screw for 20195	針振りレバーピン止ネジ	1
41	22584	Needle Driving Slider, Complete Set	針案内(組)	1
42	4133	Screw for 22584	針案内(組)止ネジ	1
43	171	Oil Wick for 22584	油芯	2
44	930	Rubber Seal for 22584	詰栓(ゴム)	1
45	21002	Needle Clamp	針止メ	1
46	4155	Screw for 21002	針止メ止ネジ	2
47		Needle (System; DC×1)	針	1
48	3637	Screw for Needle	針止ネジ	1
49-1	21768	Stitch Plate (03)	針板(03)	1
49-2	21769	" " (04)	" (04)	1
49-3	21774	" " (05)	" (05)	1
49-4	21775	" " (06)	" (06)	1
50	5345	Screw for Stitch Plate	針板止ネジ	2
51	20220	Stitch Plate Support	針板受ケ	1
52	1156	Screw for 20220	針板受ケ止ネジ	2
53	32604	Rubber Cushion (Large)	埋メ座(大)	1
54	20072	Rubber Cushion (Small)	埋メ座(小)	1
55	20238	Stitch Plate Positioner	針板位置決メ片	1
56	20223	Needle Guard (Front)	針受ケ(前)	1
57	4404	Screw for 20223	針受ケ(前)止ネジ	1

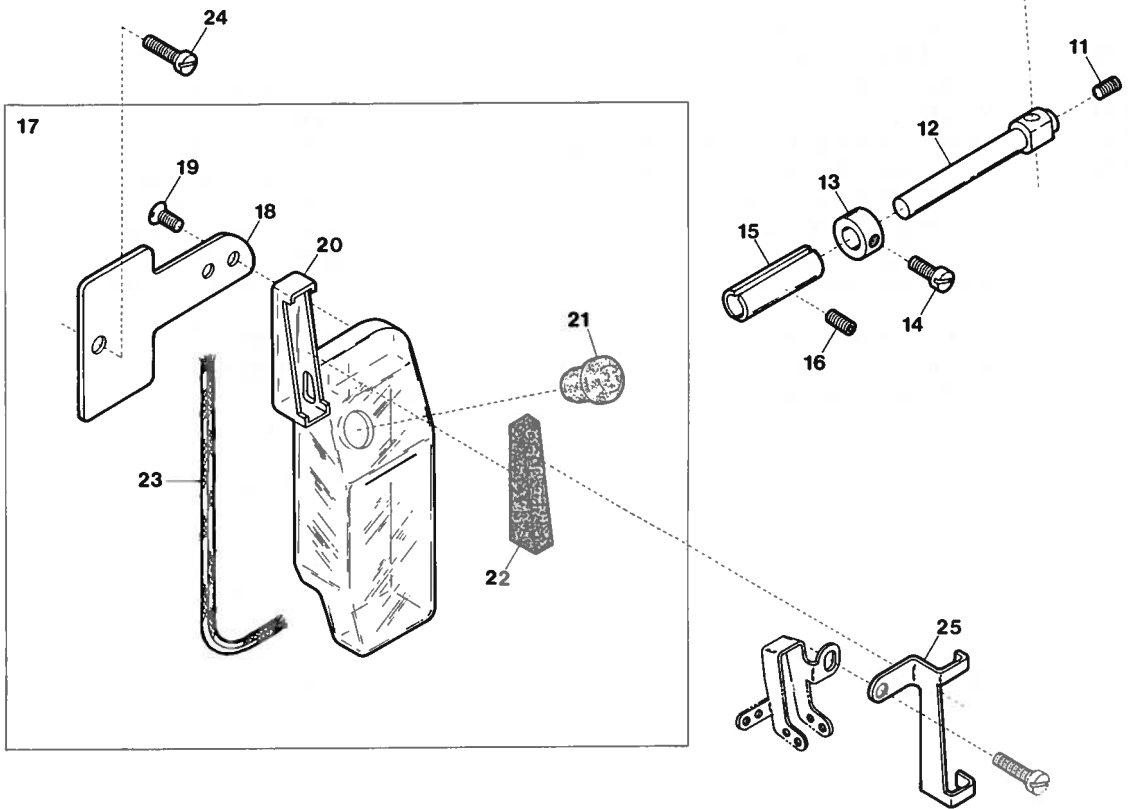
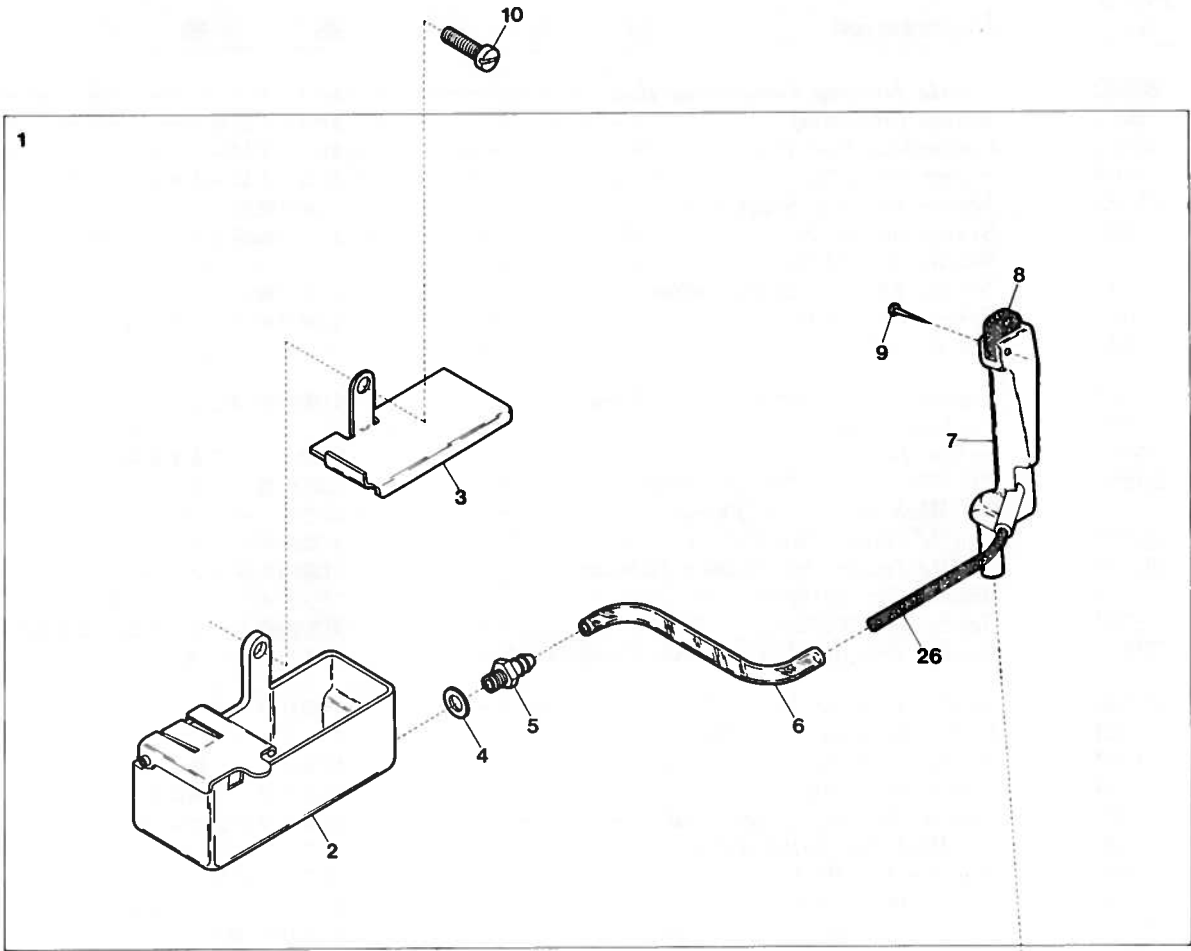

Ref. No.	Parts No.	Description	品名	Amt. Req.
1	22770	HR Unit, Complete Set	HR装置(組)	1
2	22771	HR Cap, Complete Set	HRカップ(組)	1
3	20651	Lid (Right) for HR Cap	HRカップ蓋	1
4	567	Seal for 9909	パッキン	1
5	9909	Pipe Joint	パイプ継手	1
6	22777	Oil Tube (82mm)	給油パイプ	1
7	22776	HR Felt Stay	HRフェルト支工	1
8	377	HR Felt	HRフェルト	1
9	755	Pin for 170	油芯止メピン	1
10	4440	Screw for 22771	HRカップ(組)止ネジ	1
11	3638	Screw for 22776	HRフェルト支工止ネジ	1
12	20230	Felt Stay Support	フェルト支工取付台	1
13	20376	Felt Stay Support Collar	フェルト支工取付台カラー	1
14	1208	Screw for 20376	フェルト支工取付台カラー止ネジ	1
15	20225	Bushing for 20230	フェルト支工取付台ブッシュ	1
16	3632	Screw for 20225	フェルト支工取付台ブッシュ止ネジ	1
17	21126	SP Unit, Complete Set	SP装置(組)	1
18	21125	Oil Container Support	SPタンク取付板	1
19	7619	Screw for 21124	SPタンク止ネジ	2
20	21124	Oil Container	SPタンク	1
21	93864	Oil Container Plug	詰栓	1
22	198	Felt for 21124	SPフェルト	1
23	240	Oil Wick for 21124	油芯(毛糸)	1
24	4353	Screw for 21125	SPタンク取付板止ネジ	1
25	21136	SP Felt Stay	SPフェルト押工	1
26	170	Oil Wick for 377 (Felt) (2.5×3×150mm)	油芯(フェルト)	1

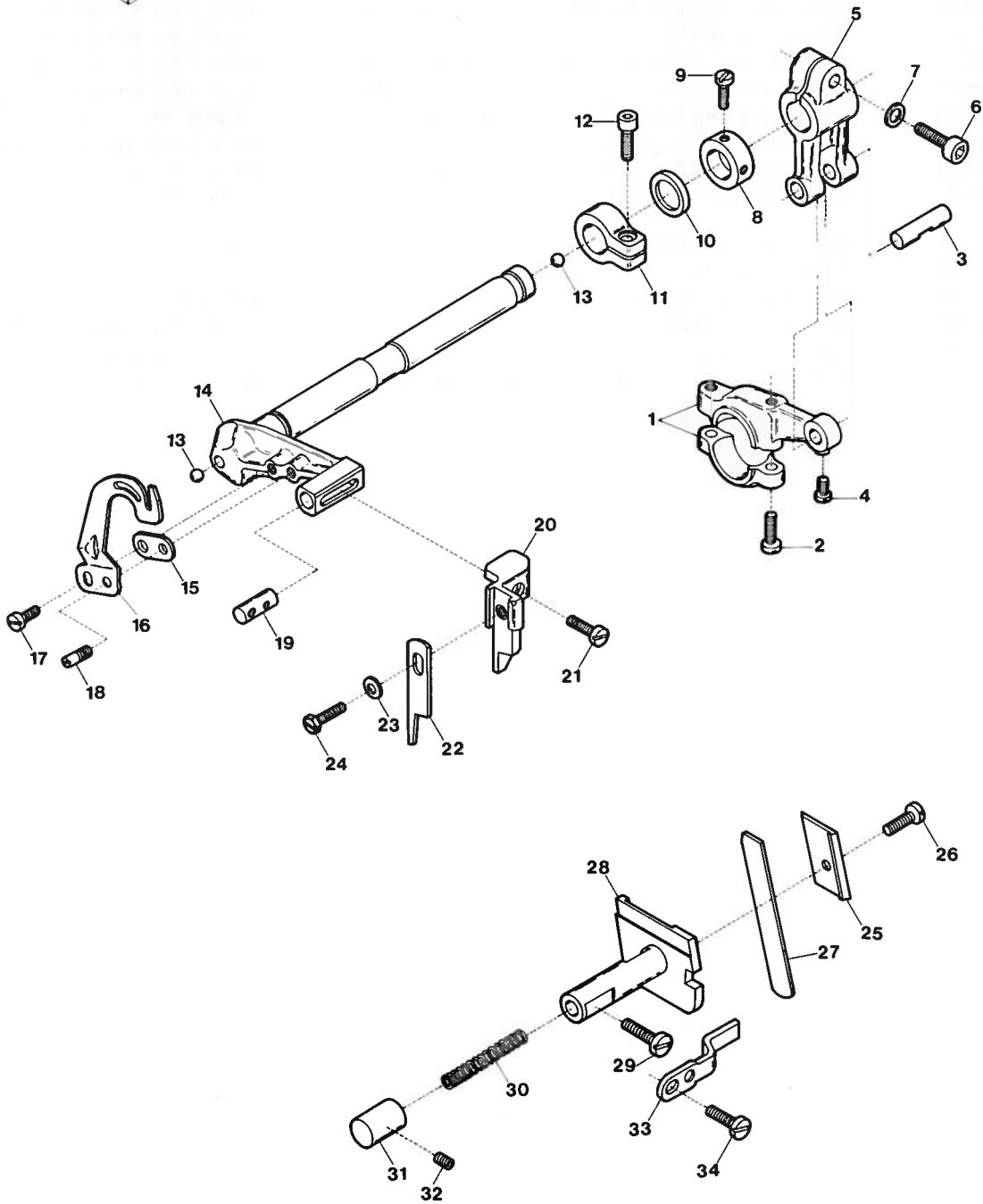
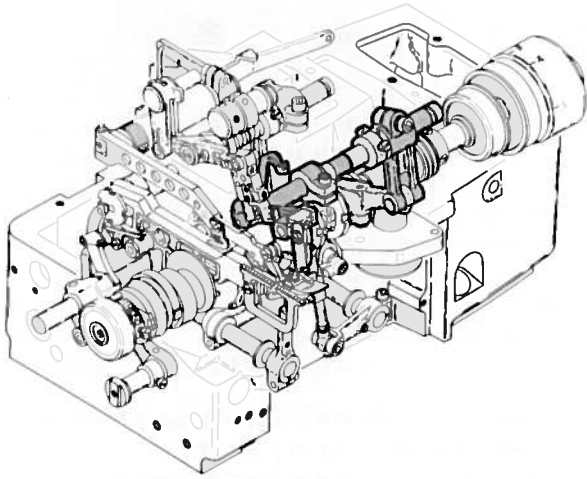

Ref. No.	Parts No.	Description	品名	Amt. Req.
1	20480	Upper Knife Driving Connecting Rod	上メスロッド	1
2	5070	Screw for 20480	上メスロッド止ネジ	2
3	32921	Connecting Rod Pin	上メスロッドピン	1
4	9508	Screw for 32921	上メスロッドピン止ネジ	1
5	21860	Upper Knife Driving Lever	上メス軸腕	1
6	5520	Screw for 21860	上メス軸腕止ネジ	1
7	520	Washer for 21860	ワッシャ	1
8	32646	Upper Knife Driving Shaft Collar (Right)	上メス軸カラー(右)	1
9	9604	Screw for 32646	上メス軸カラー(右)止ネジ	2
10	20487	Thrust Washer	上メス軸スラストリング	1
11	32920	Upper Knife Driving Shaft Collar (Left)	上メス軸カラー(左)	1
12	5550	Screw for 32920	上メス軸カラー(左)止ネジ	1
13	639	Seal Plug for 21669	詰栓	2
14	21669	Upper Knife Driving Shaft	上メス軸	1
15	21684	Needle Thread Pull-off Spacer	針糸繰リスペース	1
16	23465	Needle Thread Pull-off	針糸繰り	1
17	4153	Screw for 23465	針糸繰り止ネジ	1
18	4147	Screw for 23465	針糸繰り止ネジ	1
19	20490	Upper Knife Holder Positioner	上メスホルダ止メ	1
20	22839	Upper Knife Holder (Flat Type)	上メスホルダ(平)	1
21	7405	Screw for 22839	上メスホルダ止ネジ	1
22	20496	Upper Knife (Flat Type)	上メス(平)	1
23	532	Washer for 20496	ワッシャ	1
24	4106	Screw for 20496	上メス止ネジ	1
25	22196	Lower Knife Clamp	下メス押エ	1
26	4106	Screw for 22196	下メス押エ止ネジ	1
27	22195	Lower Knife	下メス	1
28	20497	Lower Knife Holder	下メス台	1
29	4591	Screw for 20497	下メス台止ネジ	1
30	32919	Lower Knife Holder Spring	下メスバネ	1
31	24029	Lower Knife Holder Spring Stopper	下メスバネ受け	1
32	3638	Screw for 24029	下メスバネ受け止ネジ	1
33	21117	Lower Knife Holder Locking Plate	下メス台回り止メ	1
34	4440	Screw for 21117	下メス台回り止メ止ネジ	2

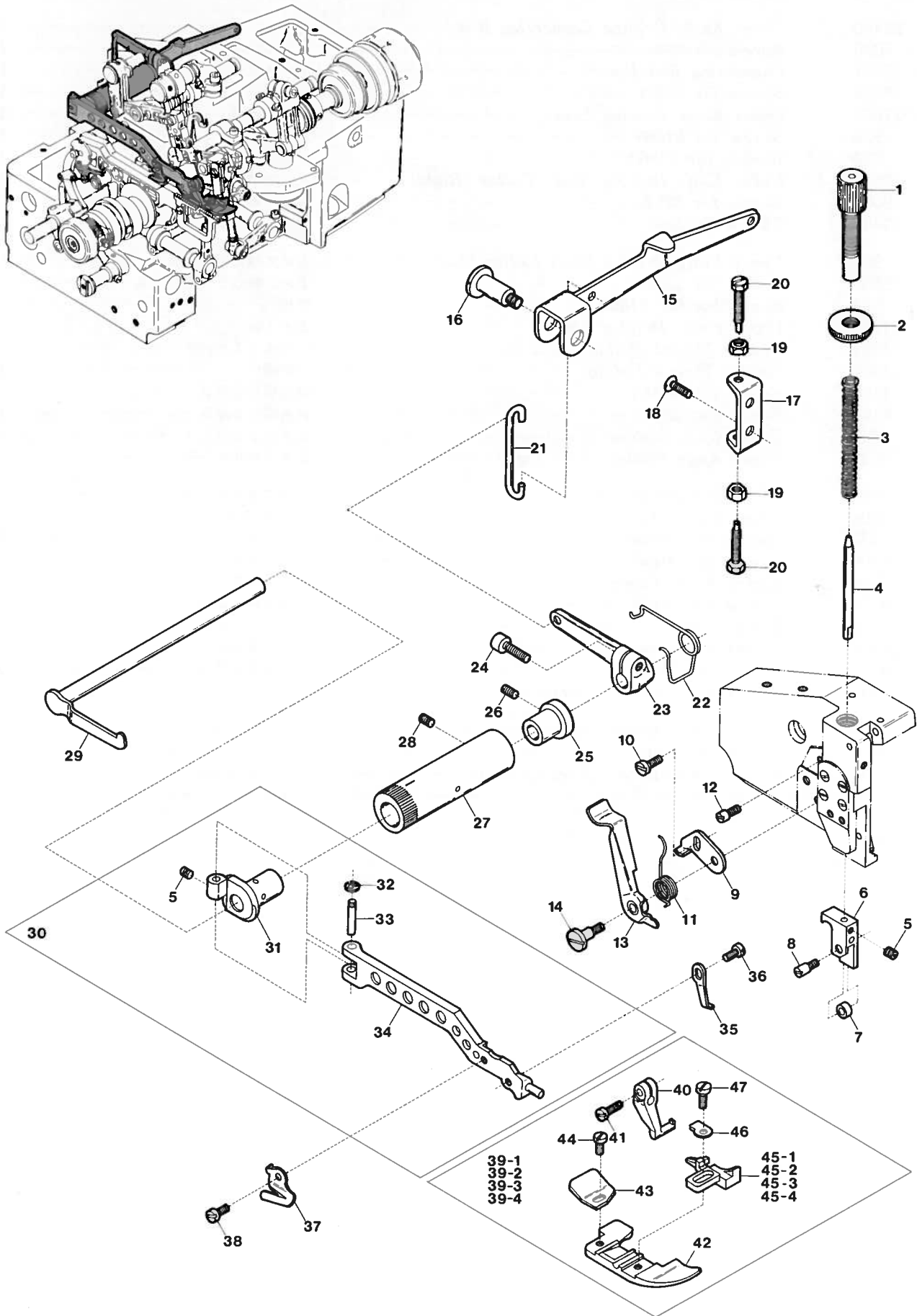

Ref. No.	Parts No.	Description	品 名	Amt. Req.
1	4119	Adjusting Screw for 22181	押工バネ調節ネジ	1
2	461	Lock Nut for 4119	ロックナット	1
3	22181	Presser Spring	押工バネ	1
4	22197	Presser Spring Guide Pin	押工バネ案内ピン	1
5	3637	Screw for 22197, 21018	止ネジ	2
6	22256	Presser Foot Positioning Guide	押工腕案内	1
7	34294	Presser Foot Roller	押工ローラ	1
8	6405	Screw for 34294	押工ローラ止ネジ	1
9	22257	Presser Arm Stopper	押工腕ストッパ	1
10	1202	Screw for 22257	押工腕ストッパ止ネジ	1
11	20293	Presser Foot Release Lever Spring	手掲ゲバネ	1
12	6094	Screw for 20293	手掲ゲバネ掛ケネジ	1
13	24080	Presser Foot Release Lever	手掲ゲ	1
14	4107	Screw for 24080	手掲ゲ止ネジ	1
15	20282	Presser Foot lifter Lever	押工掲ゲレバー	1
16	4103	Screw for 20282	押工掲ゲレバー止ネジ	1
17	20283	Presser Foot Lifer Lever Stopper	押工掲ゲストッパ	1
18	9127	Screw for 20283	押工掲ゲストッパ止ネジ	2
19	334	Lock Nut for 5505	ロックナット	2
20	5505	Adjusting Screw for 20282	押工掲ゲレバー調節ネジ	2
21	20281	Presser Foot Lifter Lever Connecting Link	押工掲ゲレバーリンク	1
22	20280	Intermediate Lever Spring	押工掲ゲ軸バネ	1
23	20279	Intermediate Lever	押工掲ゲ軸レバー	1
24	5550	Screw for 20279	押工掲ゲ軸レバー止ネジ	1
25	20300	Presser Foot Lifter Lever Shaft Sleeve	押工掲ゲ軸スリーブ	1
26	7650	Screw for 20300	押工掲ゲ軸スリーブ止ネジ	1
27	20299	Presser Foot Lifter Lever Shaft Bushing	押工掲ゲ軸ブッシュ	1
28	3639	Screw for 20299	押工掲ゲ軸ブッシュ止ネジ	1
29	20276	Presser Foot Lifter Lever Shaft	押工掲ゲ軸	1
30	22267	Presser Arm, Complete Set	押工腕(組)	1
31	22255	Presser Arm Hinge	押工腕ヒンジ	1
32	34293	Retaining Ring	ストップリング	1
33	21018	Presser Arm Hinge Pin	押工腕ヒンジピン	1
34	22252	Presser Arm	押工腕	1
35	21015	Presser Foot Half-stay	半固定片	1
36	4096	Screw for 21015	半固定片止ネジ	1
37	20271	Thread Chain Cutting Knife	チェーンカッタ	1
38	4097	Screw for 20271	チェーンカッタ止ネジ	1
39-1	23000	Presser Foot, Complete Set (03)	押工(組)(03)	1
39-2	23002	" " " " (04)	" (04)	1
39-3	23004	" " " " (05)	" (05)	1
39-4	23006	" " " " (06)	" (06)	1
40	21938	Presser Foot Hinge	押工ヒンジ	1
41	4351	Screw for 21938	押工ヒンジ止ネジ	1
42	21967	Presser Foot (Lower)	押工(下)	1
43	34535	Presser Foot Chain Shield	空糸押工	1
44	1228	Screw for 34535	空糸押工止ネジ	1
45-1	21871	Presser Foot Stitch Tongue (03)	爪	1
45-2	21872	" " " " (04)	"	1
45-3	21873	" " " " (05)	"	1
45-4	21874	" " " " (06)	"	1
46	21005	Presser Foot Hinge Spring	押工ヒンジバネ	1
47	4131	Screw for 21005	押工ヒンジバネ止ネジ	1

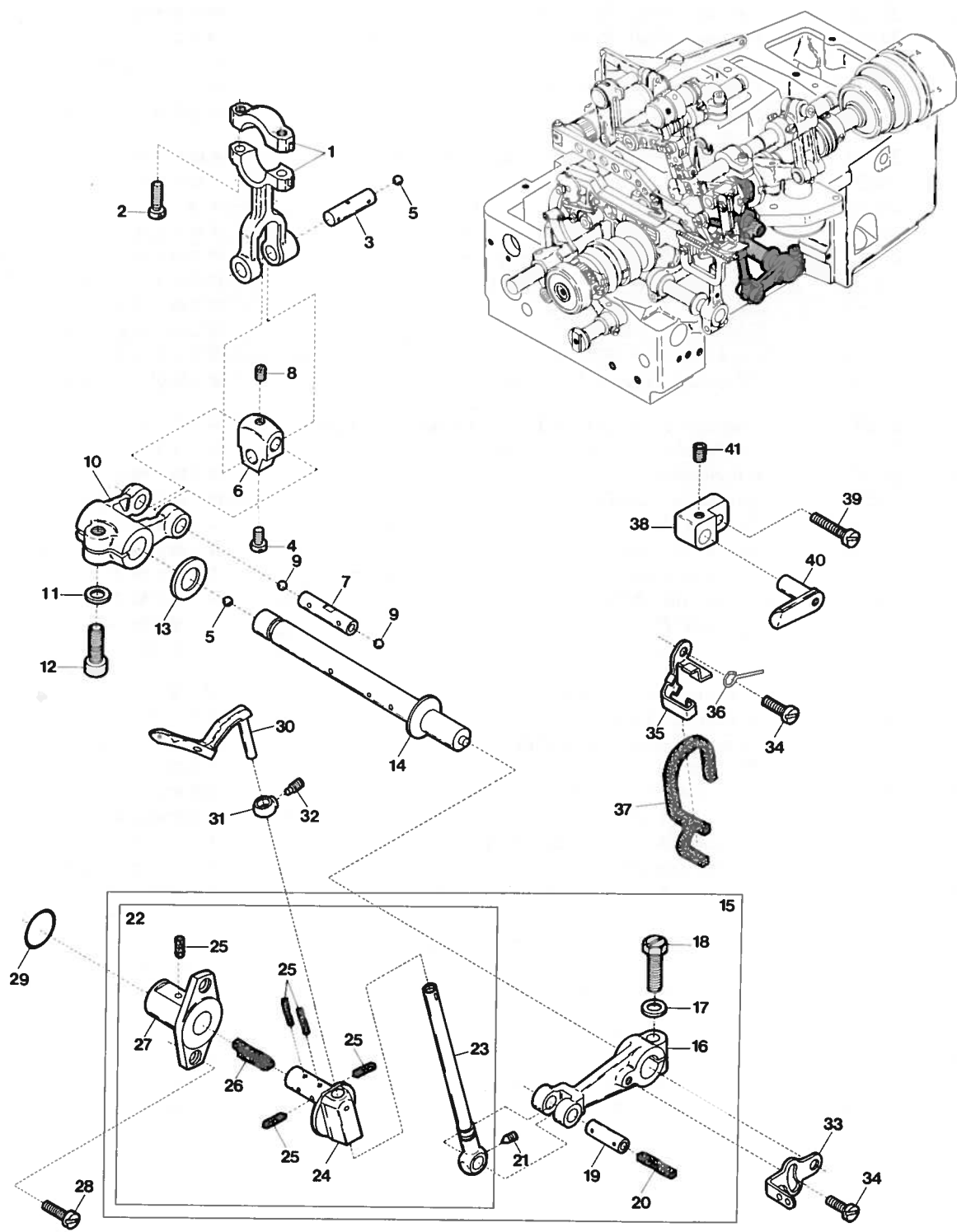

Ref. No.	Parts No.	Description	品 名	Amt. Req.
1	24191	Upper Looper Driving Lever Connecting Rod	上ルーパロッド	1
2	5070	Screw for 24191	上ルーパロッド止ネジ	2
3	24194	Looper Driving Lever Connecting Rod Pin	上ルーパロッドピン	1
4	4410	Screw for 24194	上ルーパロッドピン止ネジ	1
5	638	Seal Plug for 24194, 24063	詰栓	2
6	24193	Looper Driving Lever Link	ルーパリンク	1
7	24195	Looper Driving Lever Link Pin	ルーパリンクピン	1
8	1457	Screw for 24195	ルーパリンクピン止ネジ	1
9	637	Seal Plug for 24195	詰栓	2
10	23470	Upper Looper Driving Lever	上ルーパ軸腕	1
11	507	Washer for 23470	ワッシャ	1
12	5108	Screw for 23470	上ルーパ軸腕止ネジ	1
13	24483	Driving Shaft Thrust Washer	スラストプレート	1
14	24482	Upper Looper Driving Shaft	上ルーパ軸	1
15	24485	Upper Looper Bar Driving Arm, Complete Set	上ルーパ腕(組)	1
16	20318	Upper Looper Bar Driving Arm	上ルーパ腕	1
17	520	Washer for 20318	ワッシャ	1
18	5522	Screw for 20318	上ルーパ腕止ネジ	1
19	20331	Upper Looper Bar Driving Arm Pin	上ルーパ腕ピン	1
20	278	Oil Wick for 20331	油芯	1
21	3313	Screw for 20331	上ルーパ腕ピン止ネジ	1
22	24484	Upper Looper Bar, Complete Set	ルーパ棒(組)	1
23	24481	Upper Looper Bar	ルーパ棒	1
24	20320	Upper Looper Bar Guide	ルーパ案内	1
25	171	Oil Wick for 20320, 22853	油芯	5
26	203	Oil Wick for 20320	油芯	1
27	22853	Upper Looper Bar Guide Bushing	ルーパ案内ブッシュ	1
28	9508	Screw for 22853	ルーパ案内ブッシュ止ネジ	2
29	77432	Seal for 22853	Oリング	1
30	21700	Upper Looper	上ルーパ	1
31	21705	Upper Looper Holder Collar	上ルーパ止メカラー	1
32	4144	Screw for 21705	上ルーパ止メカラー止ネジ	1
33	20112	Looper Thread Pull-off	ルーパ糸繰り	1
34	4358	Screw for 20112, 20330	止ネジ	2
35	20330	Looper Bar Oil Wick Holder Plate	ルーパ棒油芯止メ板	1
36	32812	Oiling Felt Retainer	フェルト押工	1
37	23468	Oil Wick for 24481	油芯	1
38	20322	Looper Bar Guide Holder Bracket	ルーパ案内押工台	1
39	7311	Screw for 20322	ルーパ案内押工台止ネジ	1
40	20323	Looper Bar Guide Holder	ルーパ案内押工	1
41	3638	Screw for 20323	ルーパ案内押工止ネジ	1

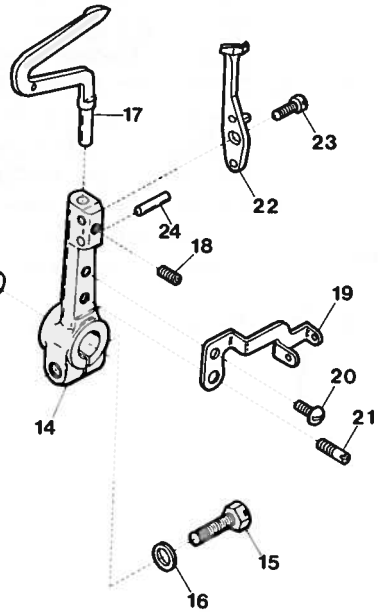
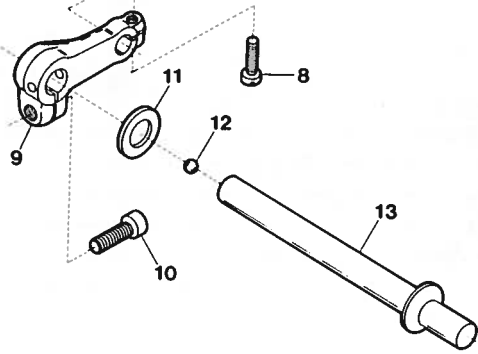
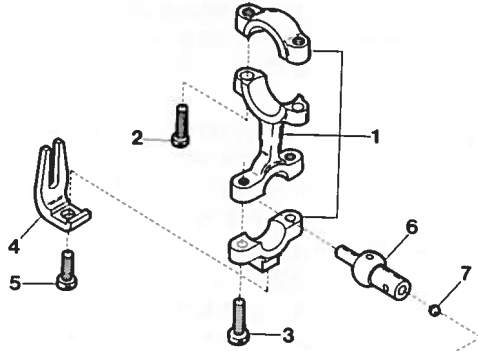
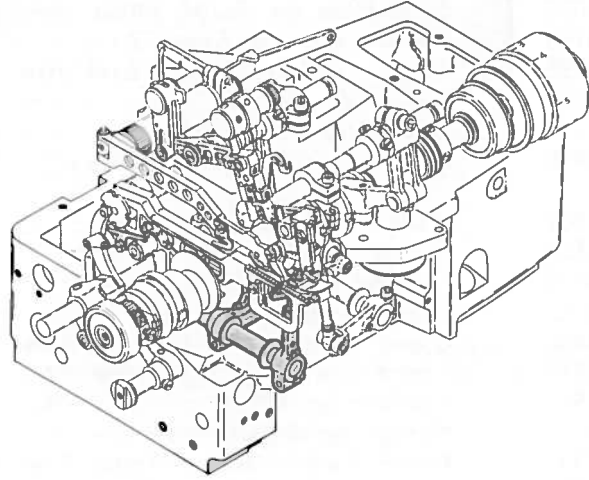

Ref. No.	Parts No.	Description	品名	Amt. Req.
1	22844	Lower Looper Driving Lever Connecting Rod	下ルーパロッド	1
2	5070	Screw for 22844	下ルーパロッド止ネジ	2
3	8101	Screw for 22844	下ルーパロッド止ネジ	2
4	20311	Ball Joint Guide Fork	振レ止メ	1
5	1202	Screw for 20311	振レ止メ止ネジ	1
6	20341	Ball Stud	下ルーパロッド球	1
7	636	Seal Plug for 20341	詰栓	1
8	4437	Screw for 20341	下ルーパロッド球止ネジ	1
9	20342	Lower Looper Driving Lever	下ルーパ軸腕	1
10	5108	Screw for 20342	下ルーパ軸腕止ネジ	1
11	34118	Thrust Washer	スラストプレート	1
12	638	Seal Plug for 20343	詰栓	1
13	20343	Lower Looper Driving Shaft	下ルーパ軸	1
14	21703	Lower Looper Holder Arm	下ルーパ台	1
15	5500	Screw for 21703	下ルーパ台止ネジ	1
16	520	Washer for 21703	ワッシャ	1
17	21701	Lower Looper	下ルーパ	1
18	3638	Screw for 21701	下ルーパ止ネジ	1
19	21717	Looper Thread Pull-off	下ルーパ糸繰り	1
20	9121	Screw for 21717	下ルーパ糸繰り止ネジ	1
21	4130	Screw for 21717	下ルーパ糸繰り止ネジ	1
22	24169	Needle Guard (Rear)	針受ケ(後)	1
23	5036	Screw for 24169	針受ケ(後)止ネジ	1
24	688	Positioning Pin for 24169	位置決メピン	1

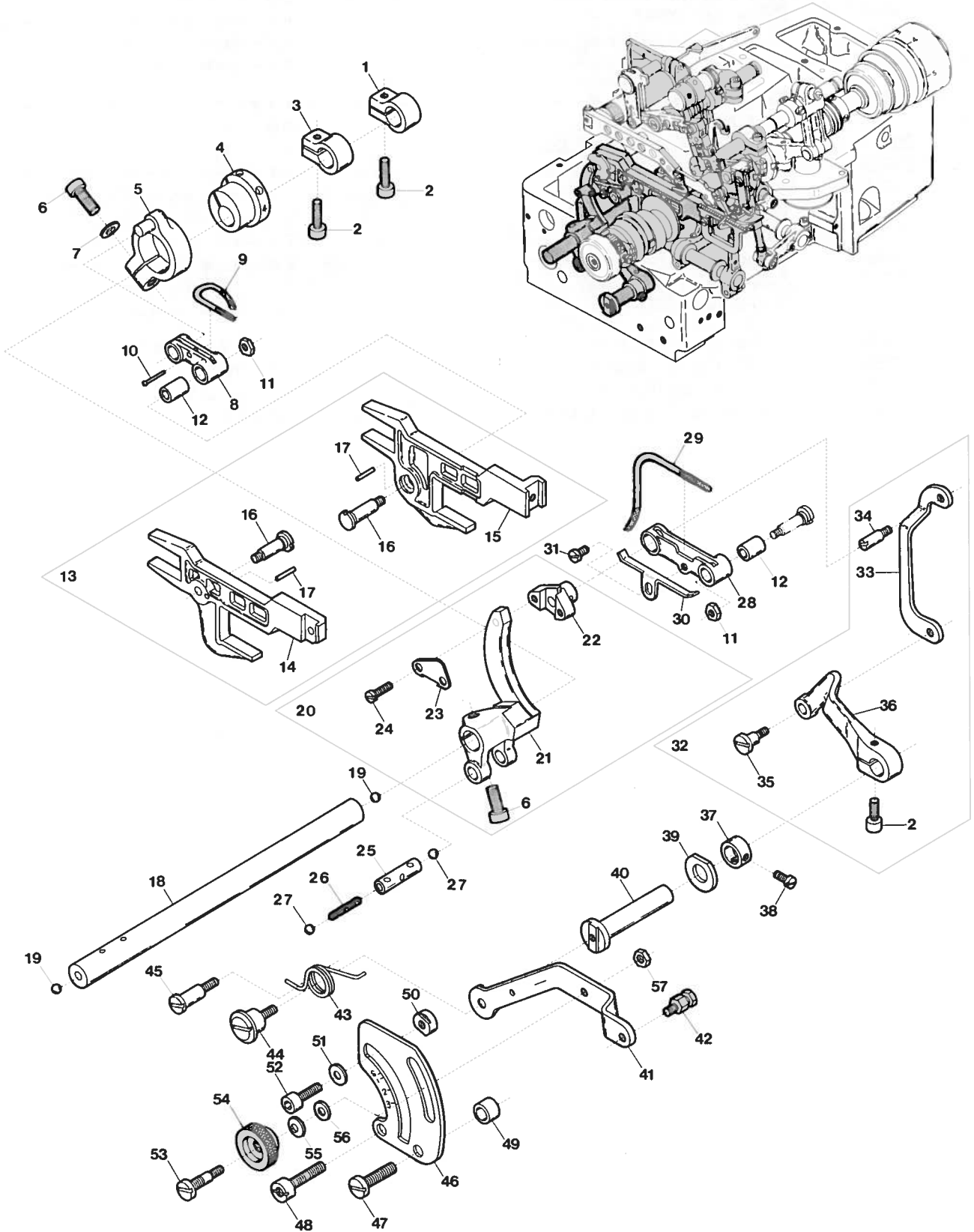

Ref. No.	Parts No.	Description	品名	Amt. Req.
1	20445	Feed Bar Driving Shaft Collar (Right)	送り軸カラー(右)	1
2	5550	Screw for 20445, 32920, 24119	止ネジ	3
3	32920	Feed Bar Driving Shaft Collar (Left)	送り軸カラー(左)	1
4	22588	Main Feed Bar Driving Lever Eccentric	後送り腕エキセン	1
5	22587	Main Feed Bar Driving Lever	後送り腕	1
6	5520	Screw for 22587, 20408	止ネジ	2
7	520	Washer for 22587	ワッシャ	1
8	20425	Main Feed Bar Driving Connection	後送りリンク	1
9	193	Oil Wick for 20425 (145mm)	油芯	1
10	755	Pin for 193	油芯止ピン	1
11	451	Nut for 33099	ナット	2
12	33098	Feed Bar Driving Connection Bushing	送りリンクブッシュ	2
13	20442	Feed Bar, Complete Set	送り台(組)	1
14	20426	Differential Feed Bar	前送り台	1
15	20427	Main Feed Bar	後送り台	1
16	33099	Feed Bar Driving Stud	送りリンクピン	2
17	687	Pin for 33099	ピン	2
18	22581	Feed Bar Driving Shaft	送り軸	1
19	639	Seal Plug for 22581	詰栓	2
20	20447	Differential Feed Rocker, Complete Set	前送り腕(組)	1
21	20408	Differential Feed Rocker	前送り腕	1
22	20413	Differential Feed Regulating Slide Pin	スライダ	1
23	20414	Differential Feed Regulating Slide Pin Cap	スライダキャップ	1
24	9624	Screw for 20414	スライダキャップ止ネジ	2
25	22852	Feed Bar Driving Connecting Rod Pin	送りロッドピン	1
26	398	Oil Wick for 22852	油芯	1
27	637	Seal Plug for 22852	詰栓	2
28	24183	Differential Feed Bar Driving Connection	前送りリンク	1
29	192	Oil Wick for 24183 (175mm)	油芯	1
30	24184	Oil Wick Holder	油芯押エ	1
31	7616	Screw for 24184	油芯押エ止ネジ	1
32	24121	Differential Feed Control Inner Lever, Complete Set	前送り調節リンク(組)	1
33	24120	Differential Feed Control Link	前送り調節リンク	1
34	5512	Screw for 24120	前送り調節リンク止ネジ	1
35	4100	Screw for 24119	前送り調節中レバー止ネジ	1
36	24119	Differential Feed Control Lever (Inner)	前送り調節中レバー	1
37	30228	Differential Feed Control Lever Shaft Collar	前送り調節レバー軸カラー	1
38	9604	Screw for 30228	前送り調節レバー軸カラー止ネジ	2
39	20436	Thrust Washer	スラストワッシャ	1
40	33118	Differential Feed Control Lever Shaft	前送り調節レバー軸	1
41	20418	Differential Feed Control Lever (Outer)	前送り調節外レバー	1
42	4143	Screw for Hanging Chain	鎖掛ケネジ	1
43	20421	Differential Feed Control Lever Spring	調節外レバーバネ	1
44	4118	Screw for 20421	調節外レバーバネ止ネジ	1
45	4110	Screw for 20421	調節外レバーバネ掛ケネジ	1
46	24122	Differential Feed Graduations	送り目盛板	1
47	9930	Screw for 24122	送り目盛板止ネジ	1
48	4146	Screw for 24122	送り目盛板止ネジ	1
49	185	Washer for 24122	ワッシャ	2
50	20420	Differential Feed Control Lever Stopper	調節外レバーストッパ	2
51	186	Washer for 20420	ワッシャ	2
52	5038	Screw for 20420	調節外レバーストッパ止ネジ	2
53	4111	Adjusting Screw for 20418	調節ネジ	1
54	181	Adjusting Nut for 20418	調節ナット	1
55	561	Spring Washer for 20418	スプリングワッシャ	1
56	520	Washer for 20418	ワッシャ	1
57	340	Nut for 20418	ナット	1

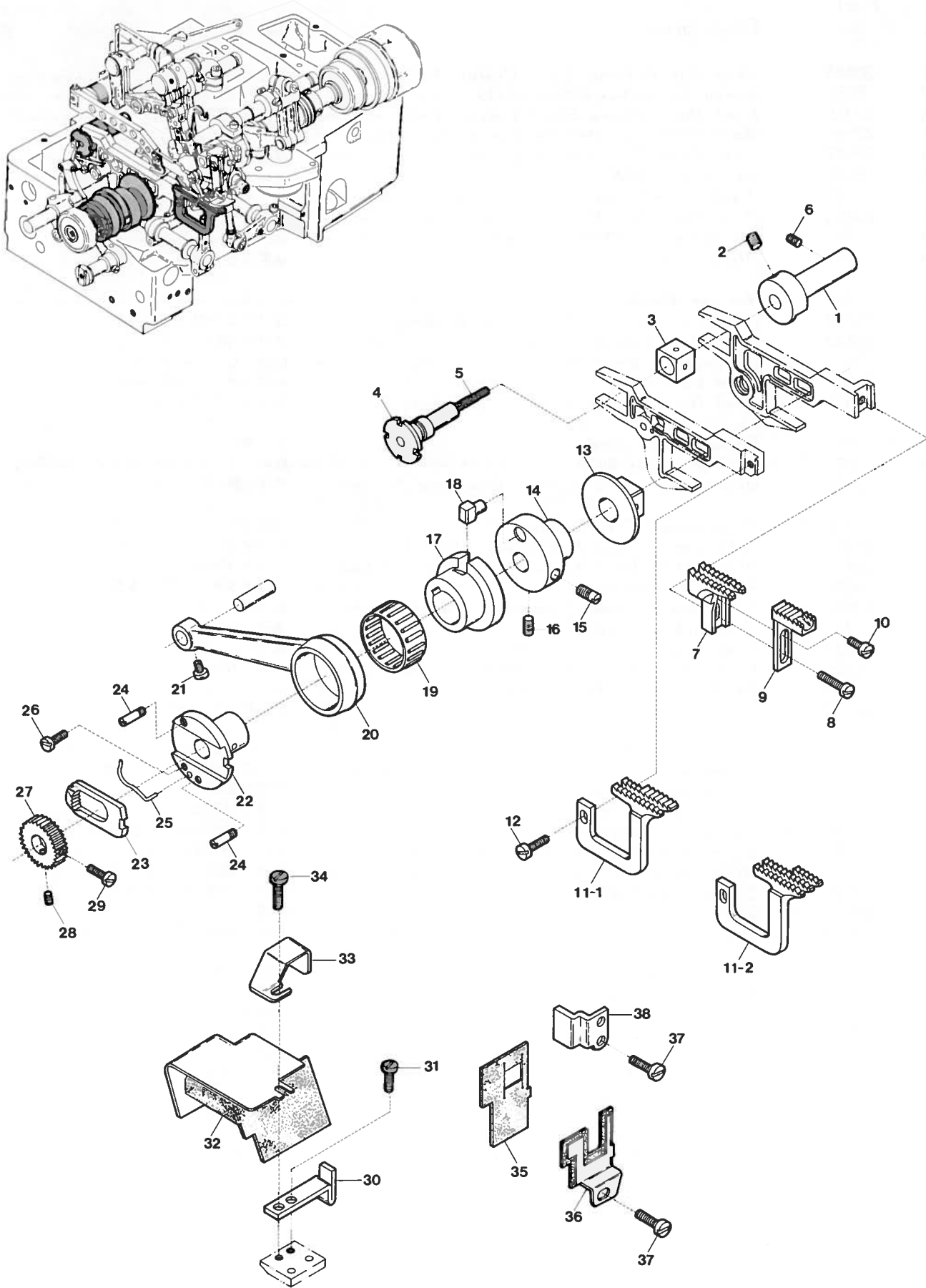

Ref. No.	Parts No.	Description	品名	Amt. Req.
1	32865	Feed Bar Guide (Rear)	送り台ガイド(後)	1
2	3632	Screw for 32865	送り台ガイド(後)止ネジ	1
3	32867	Feed Bar Guide Block	角駒(小)	1
4	33141	Feed Adjusting Eccentric Pin	エキセンピン	1
5	223	Oil Wick for 33141	油芯	1
6	3635	Screw for 33141	エキセンピン止ネジ	1
7	21842	Main Feed Dog	後送り	1
8	7609	Screw for 21842	後送り止ネジ	1
9	21009	Auxiliary Feed Dog	小送り	1
10	9730	Screw for 21009	小送り止ネジ	1
11-1	21846	Differential Feed Dog (03), (04)	前送り (03, 04)	1
11-2	21847	" " " (05), (06)	前送り (05, 06)	1
12	4353	Screw for Differential Feed Dog	前送り止ネジ	1
13	20432	Feed Lift Block	角駒(大)	1
14	24067	Feed Dog Regulating Eccentric Pin Holder	送りエキセンピン取付台	1
15	3405	Screw for 24067	送りエキセンピン取付台止ネジ	1
16	3436	Screw for 24067	送りエキセンピン取付台止ネジ	1
17	20400	Feed Dog Regulating Eccentric	送りエキセン	1
18	20401	Feed Dog Regulating Eccentric Pin	送りエキセンピン	1
19	77322	Roller Bearing for 20406	ニードルベアリング	1
20	20406	Feed Dog Driving Connecting Rod	送りロッド	1
21	4410	Screw for Connecting Rod Pin	止ネジ	1
22	20452	Feed Dog Regulating Control Eccentric	送り調節エキセン	1
23	23473	Feed Dog Regulating Plate	送り調節プレート	1
24	4109	Stopper Screw for 20452	送り調節エキセンストップネジ	2
25	20454	Feed Dog Regulating Plate Spring	送り調節プレートバネ	1
26	4099	Main Screw for 20452	送り調節プレートバネ決メネジ	1
27	20455	Feed Dog Regulating Gear	送り調節ギア	1
28	3638	Screw for 20455	送り調節ギア止ネジ	1
29	9508	Screw for 20455	送り調節ギア止ネジ	1
30	20428	Feed Bar Guide (Left)	送り台ガイド(左)	1
31	9853	Screw for 20428	送り台ガイド(左)止ネジ	1
32	20450	Feed Dog Driving Connecting Rod Cover	送りロッドカバー	1
33	21191	Feed Lift Block Guide	角駒ガイド	1
34	4440	Screw for 20433, 20429	止ネジ	3
35	20430	Feed Bar Shield	送り台シール	1
36	20433	Feed Mechanism Front Shield	送り前カバー	1
37	20429	Feed Bar Guide (Right)	送り台ガイド(右)	1

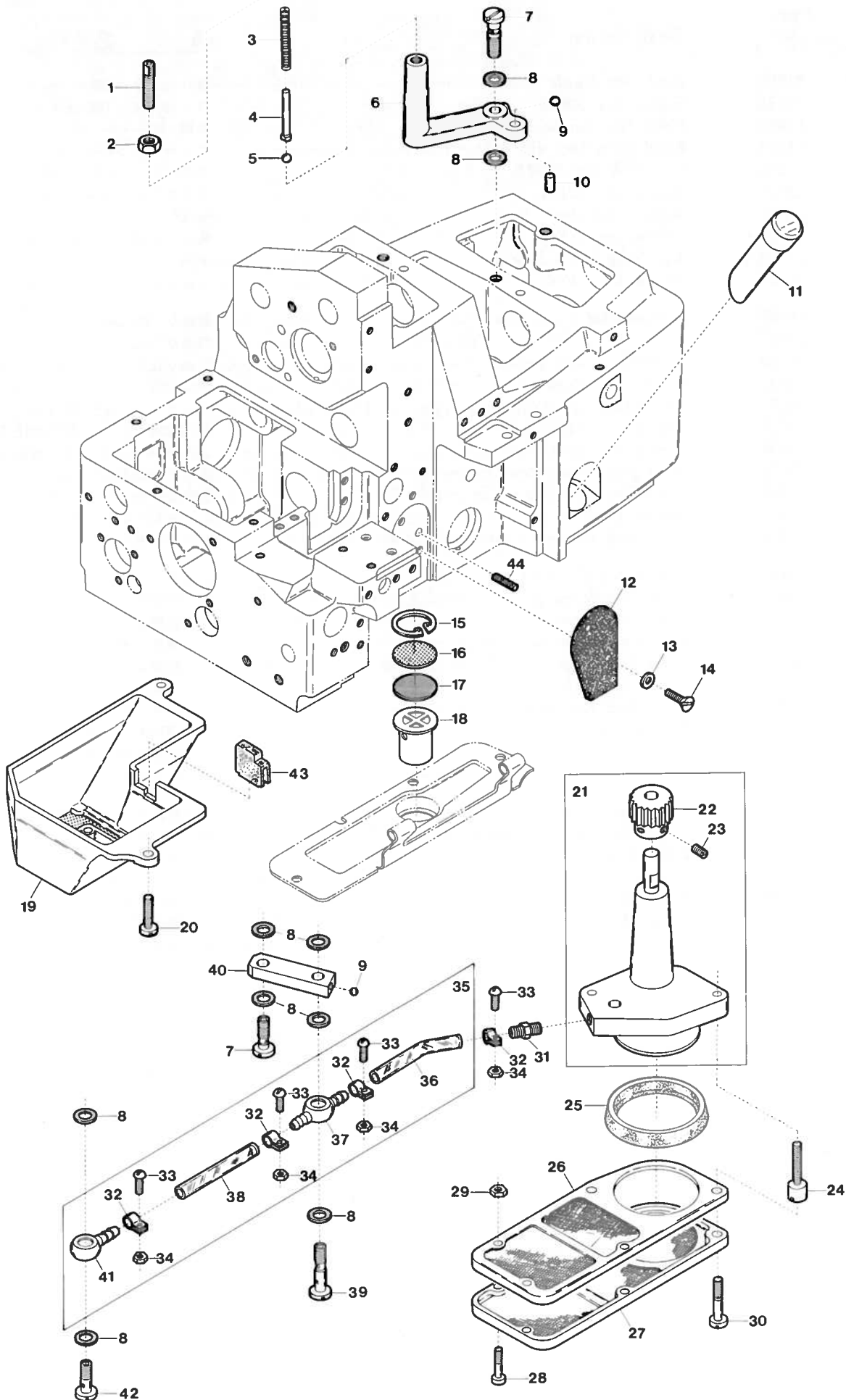

Ref. No.	Parts No.	Description	品名	Amt. Req.
1	20534	Oil Sight Nozzle	ノズル	1
2	419	Nut for 20534	ナット	1
3	30745	Oil Pressure Regulating Valve Spring	調圧弁バネ	1
4	30748	Oil Pressure Regulating Valve Spring Guide	調圧バネ案内ピン	1
5	80503	Oil Pressure Regulating Ball	調圧ボール弁	1
6	20535	Oil Pressure Regulating Valve	調圧弁座	1
7	4124	Oil Tube Fitting Stud (Short)	管継手ボルト(短)	2
8	567	Seal for 20535, 37668, 20539, 33980	パッキン	9
9	638	Seal Plug for 20535, 20539	詰栓	2
10	651	Pin for 20535	ピン	1
11	21010	Oil Sight Gauge	オイルゲージ	1
12	20325	Upper Looper Bar Oiling Felt	ルーパフェルト	1
13	538	Washer for 20325	ワッシャ	2
14	7619	Screw for 20325	ルーパフェルト止ネジ	2
15	20020	Filter Screen Clamp	前カバー汙過網押エ	2
16	20019	Front Cover Filter Screen (Coarse Mesh)	前カバー汙過網(荒目)	1
17	24166	Front Cover Filter Screen	前カバー汙過網	1
18	24167	Front Cover Filter Screen Holder	前カバー汙過網受ケ	1
19	20546	Feed Mechanism Filter Screen	送り汙過網	1
20	9150	Screw for 20546	送り汙過網止ネジ	2
21	20526	Oil Pump, Complete Set	ポンプ(組)	1
22	20520	Worm Wheel	ウォームホイール	1
23	4108	Screw for 20520	ウォームホイール止ネジ	2
24	4115	Screw for 20526	ポンプ(組)止ネジ	2
25	20530	Pump Filter Screen Sleeve	ポンプ汙過網スリーブ	1
26	20531	Pump Filter Screen (Upper)	ポンプ汙過網(上)	1
27	20532	Pump Filter Screen (Lower)	ポンプ汙過網(下)	1
28	4116	Screw for 20531, 20532	ポンプ汙過網止ネジ	3
29	180	Nut for 20531, 20532	ナット	3
30	5004	Screw for Pump Filter Screen	ポンプ汙過網止ネジ	2
31	9909	Oil Tube Fitting Nut	パイプ継手	1
32	32944	Oil Tube Clamp	緊束環	4
33	9989	Screw for 32944	緊束環止ネジ	4
34	15	Nut for 32944	ナット	4
35	20554	Oil Lubricating Tube, Complete Set	給油パイプ(組)	1
36	33668	Oil Tube (4×6×50mm)	給油パイプ(50mm)	1
37	37668	Oil Tube Fitting Two Way	両口管継手	1
38	32949	Oil Tube (4×6×58mm)	給油パイプ(58mm)	1
39	4126	Oil Tube Fitting Stud (Long)	管継手ボルト(長)	1
40	20539	Lubricant Guiding Block	給油ブロック	1
41	33980	Oil Tube Fitting One Way End	片口管継手	1
42	7668	Oil Tube Fitting Stud	管継手ボルト	1
43	20552	Feed Mechanism Filter Screen Side Cover	送り汙過網横蓋	1
44	376	Oil Wick for Machine Frame	油芯	1

UPPER KNIFE (ANGLED TYPE) ASSEMBLY

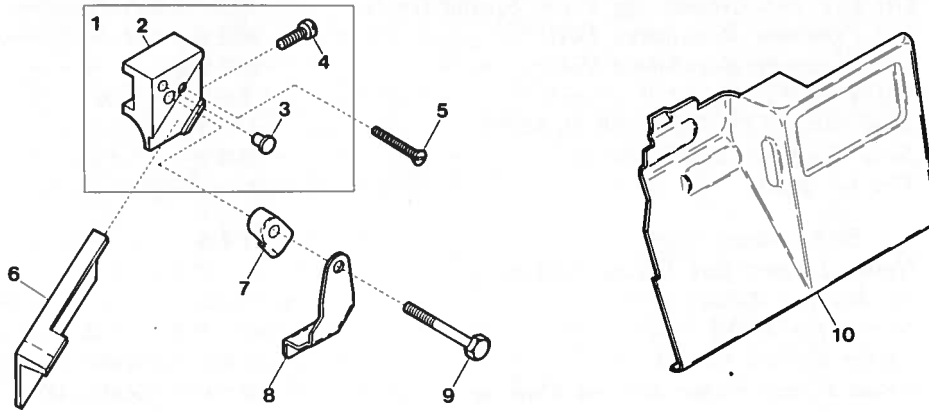

Z5003-03-2

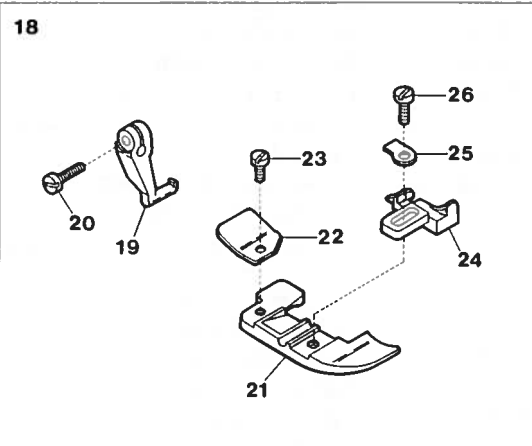
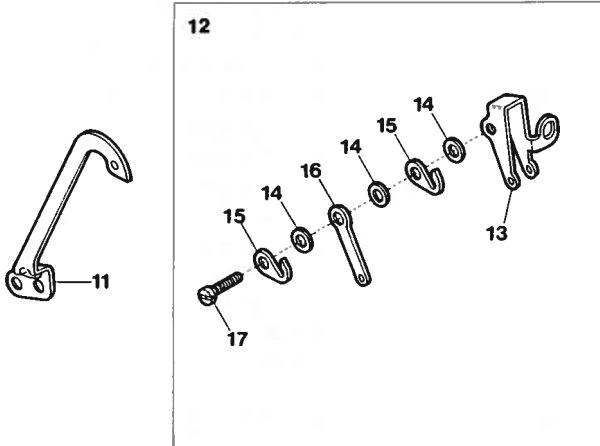

Z5003-04-3

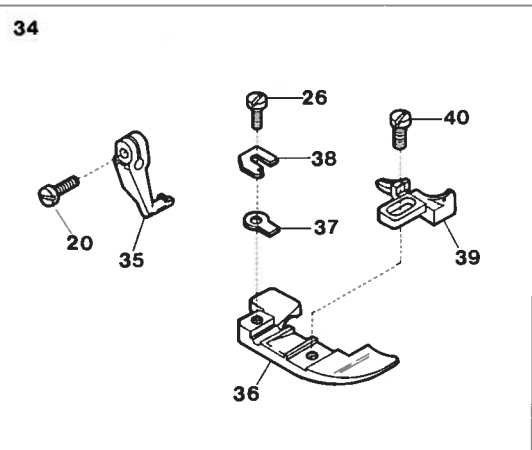
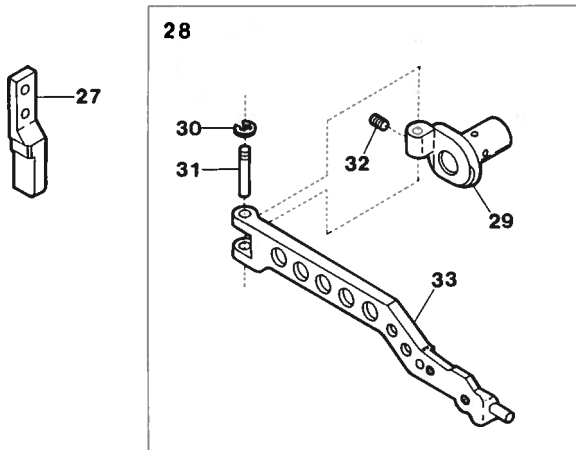

**EXCLUSIVE PARTS for UPPER KNIFE (Angled Type),
Z5003-2, 5003-3**

**角メス及び
サブモデル専用部品**

15

Ref. No.	Parts No.	Description	品名	Amt. Req.
1	22198	Upper Knife Holder, Complete Set	上メスホルダ(角)(組)	1
2	22778	Upper Knife Holder	上メスホルダ	1
3	20489	Upper Knife Holder Packing	上メスホルダ埋メ座	1
4	4404	Stopper Screw for 20491	上メスストップバネジ	1
5	4105	Screw for 22778	上メスホルダ止ネジ	1
6	20491	Upper Knife	上メス	1
7	20492	Upper Knife Clamp	上メス押工	1
8	22759	Upper Knife Chip Guard	切屑押シ	1
9	4104	Screw for 22759	切屑押シ止ネジ	1
10	22749	Front Cover	前カバー	1
11	22674	Needle Thread Pull-off	針糸繰り	1
12	22670	Needle Thread Eyelet, Complete Set	針糸道(組)	1
13	22671	Needle Thread Eyelet (Large)	針糸道(大)	1
14	532	Washer for 22673, 22672	ワッシャ	3
15	22673	Needle Thread Guide	針糸案内	2
16	22672	Needle Thread Eyelet (Small)	針糸道(小)	1
17	7405	Screw for 22673	針糸案内止ネジ	1
18	23024	Presser Foot, Complete Set	押工(組)	1
19	21938	Presser Foot Hinge	押工ヒンジ	1
20	4351	Screw for 21938, 21242	押工ヒンジ止ネジ	1
21	21967	Presser Foot (Lower)	押工(下)	1
22	34535	Presser Foot Chain Shield	空糸押工	1
23	1228	Screw for 34535	空糸押工止ネジ	1
24	21884	Presser Foot Stitch Tongue	爪	1
25	21005	Presser Foot Hinge Spring	押工ヒンジバネ	1
26	4131	Screw for 21005, 22519	止ネジ	1
27	20663	Dust Proof-off Block	防塵ブロック	1
28	22268	Presser Arm, Complete Set	押工腕(組)	1
29	22255	Presser Arm Hinge	押工腕ヒンジ	1
30	34293	Retaining Ring	ストップリング	1
31	21018	Presser Arm Hinge Pin	押工腕ヒンジピン	1
32	3637	Screw for 21018	押工腕ヒンジピン止ネジ	1
33	22253	Presser Arm	押工腕	1
34	22521	Presser Foot, Complete Set	押工(組)	1
35	21242	Presser Foot Hinge	押工ヒンジ	1
36	21240	Presser Foot (Lower)	押工(下)	1
37	21243	Presser Foot Hinge Spring	押工ヒンジバネ	1
38	22519	Presser Foot Adjusting Plate	押工調節片	1
39	21872	Presser Foot Stitch Tongue	爪	1
40	4138	Screw for 21872	爪止ネジ	1

Z5000

3

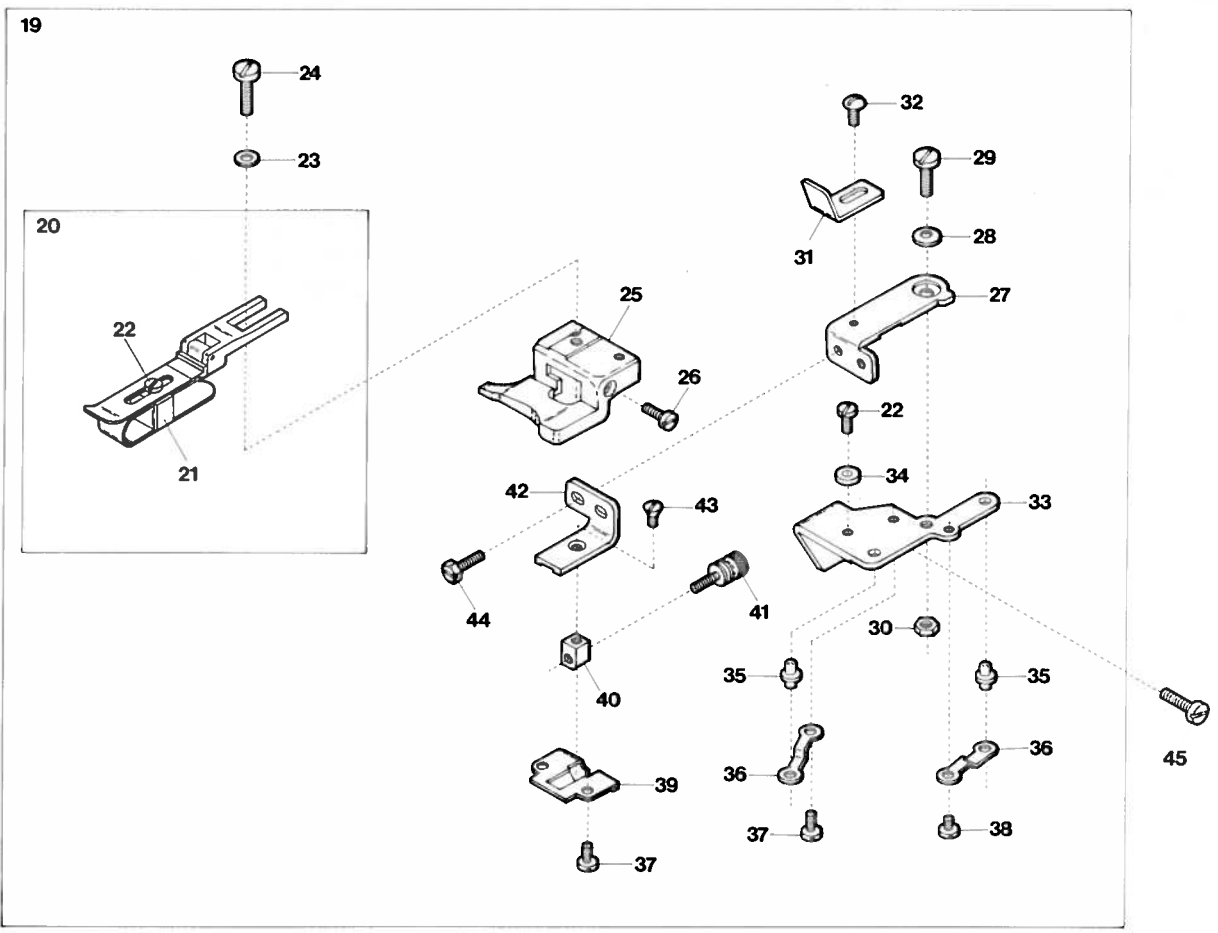
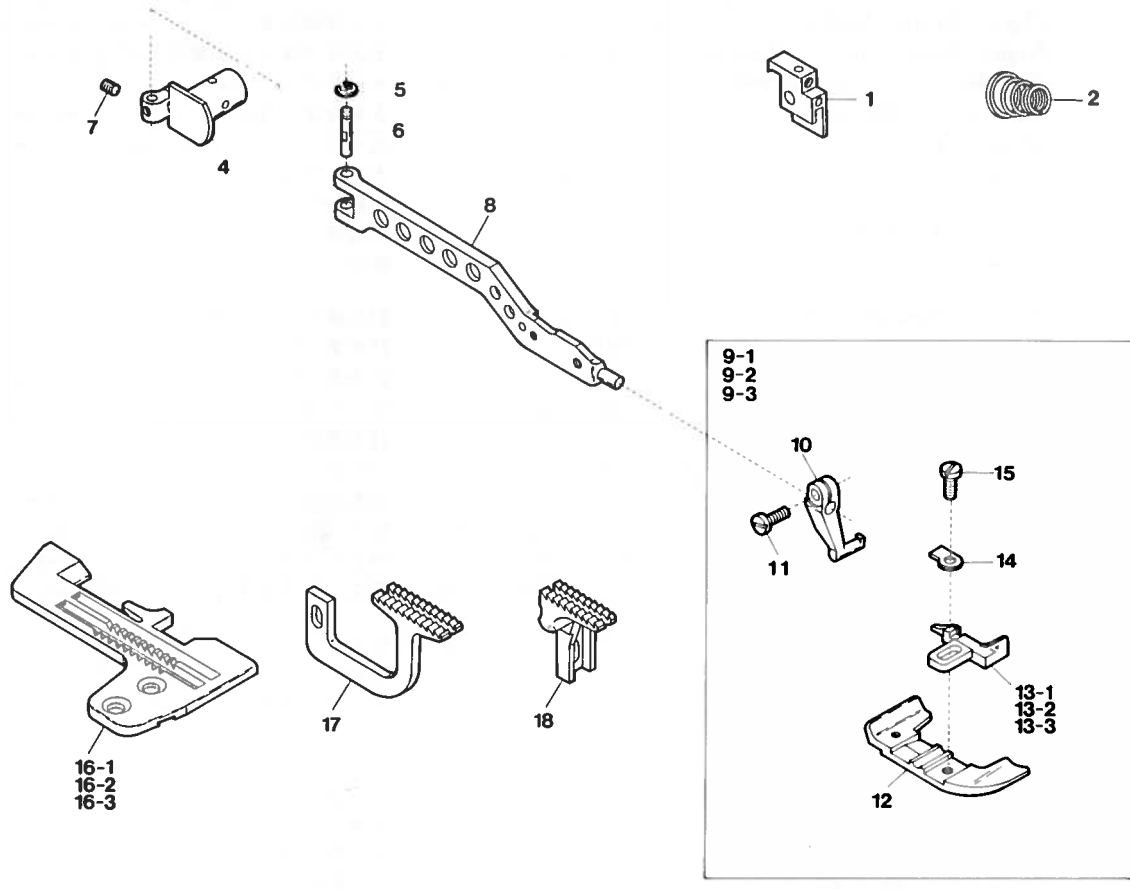

Ref. No.	Parts No.	Description	品 名	Amt. Req.
1	22269	Presser Foot Positioning Guide	押工腕案内	1
2	30255	Needle and Lower Looper Thread Tension Spring	糸調子バネ	2
3	22239	Presser Arm, Complete Set	押工腕(組)	1
4	22255	Presser Arm Hinge	押工腕ヒンジ	1
5	34293	Retaining Ring	ストップリング	1
6	21018	Presser Arm Hinge Pin	押工腕ヒンジピン	1
7	3637	Screw for 21018	押工腕ヒンジピン止ネジ	1
8	22240	Presser Arm	押工腕	1
9-1	21940	Presser Foot, Complete Set (03)	押工(組)(03)	1
9-2	21941	" " " (04)	" (04)	1
9-3	21942	" " " (05)	" (05)	1
10	21938	Presser Foot Hinge	押工ヒンジ	1
11	4351	Screw for 21938	押工ヒンジ止ネジ	1
12	21939	Presser Foot (Lower)	押工(下)	1
13-1	21880	Presser Foot Stitch Tongue (03)	爪(03)	1
13-2	21881	" " " (04)	" (04)	1
13-3	21882	" " " (05)	" (05)	1
14	21005	Presser Foot Hinge Spring	押工ヒンジバネ	1
15	4131	Screw for 21005	押工ヒンジバネ止ネジ	1
16-1	21759	Stitch Plate (03)	針板(03)	1
16-2	21761	" " (04)	" (04)	1
16-3	21763	" " (05)	" (05)	1
17	21840	Differential Feed Dog	前送り	1
18	21841	Main Feed Dog	後送り	1
19	22439	Blind-Hemming Guide, Complete Set	裾引定規(組)	1
20	21337	Overhanging Guide Hinge, Complete Set	定規(組)	1
21	34867	Hemming Positioner	裾引幅調節片	1
22	5036	Screw for 34867, 22448	止ネジ	1
23	533	Washer for 21337	ワッシャ	1
24	7006	Screw for 21337	定規(組)止ネジ	1
25	22441	Blind-Hemming Edge Guide	裾引定規台	1
26	9624	Stopper Screw for 22441	ストップバネジ	1
27	22445	Swing-out Lever	スイングアウトレバー	1
28	172	Spring Washer for 22445	スプリングワッシャ	1
29	4150	Screw for 22445	スイングアウトレバー止ネジ	1
30	334	Nut for 22445	ナット	1
31	22446	Stopper for 21337	定規ストップバ	1
32	1330	Screw for 22446	定規ストップバ止ネジ	1
33	22447	Swing-out Lever Holder	スイングアウトレバー取付台	1
34	22448	Swing-out Lever Stopper	スイングアウトレバーストップバ	1
35	22435	Edge Guide Positioning Pin	定規固定ピン	2
36	22436	Edge Guide Positioning Pin Holder Spring	定規固定ピン押エバネ	2
37	1196	Screw for 22436, 22444	止ネジ	3
38	1227	Screw for 22436	定規固定ピン押エバネ止ネジ	1
39	22444	Edge Guide Adjusting Holder Cover	裾引調節台蓋	1
40	22443	Adjusting Screw Guide Piece	調節ネジガイド	1
41	6444	Adjusting Screw for 22441	裾引定規台調節ネジ	1
42	22442	Edge Guide Adjusting Holder	裾引調節台	1
43	7619	Screw for 22443	調節ネジガイド止ネジ	1
44	4106	Screw for 22442	裾引調節台止ネジ	2
45	9150	Screw for 22447	スイングアウトレバー取付台止ネジ	2

Z5006,5016

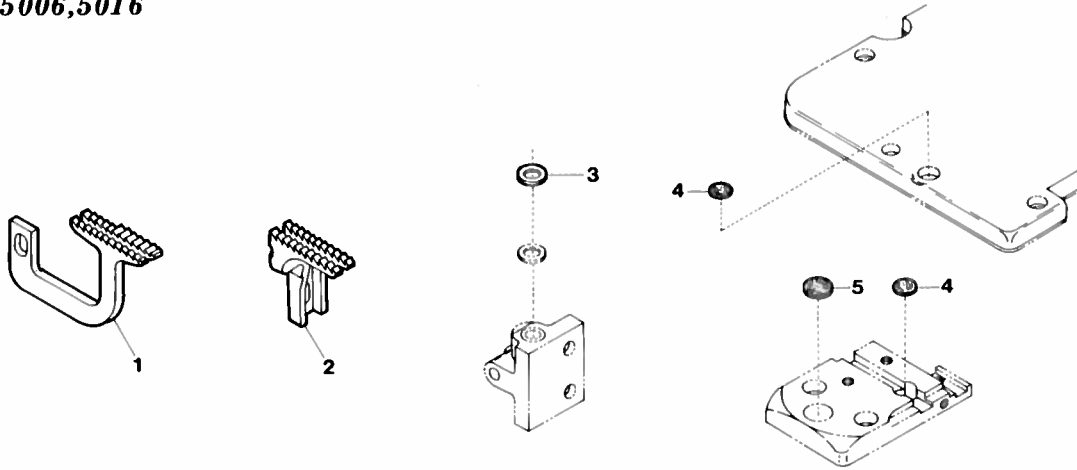

Z5006

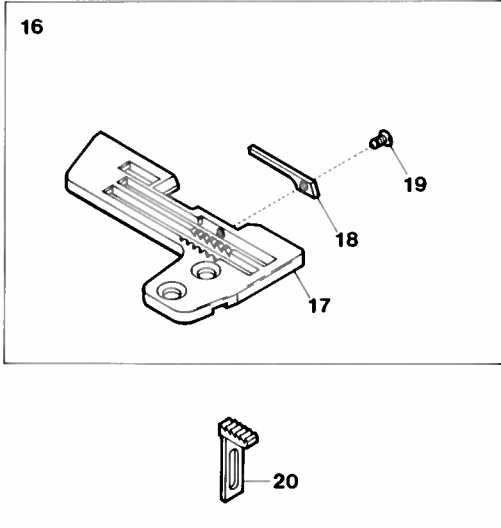
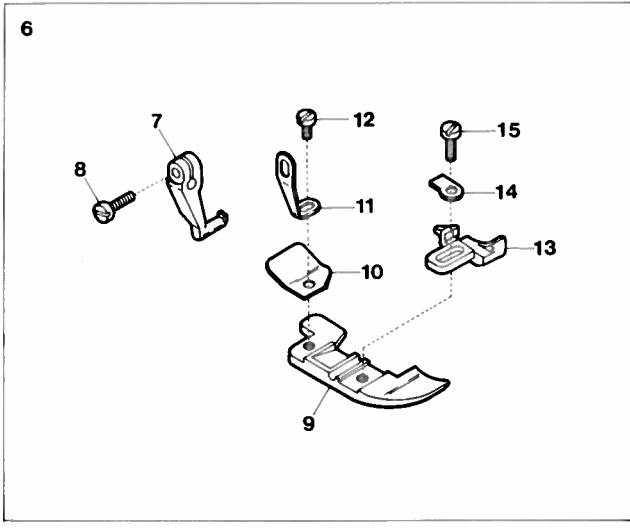

Z5016

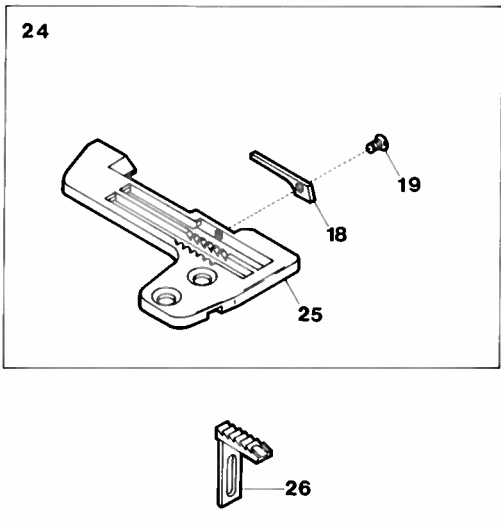
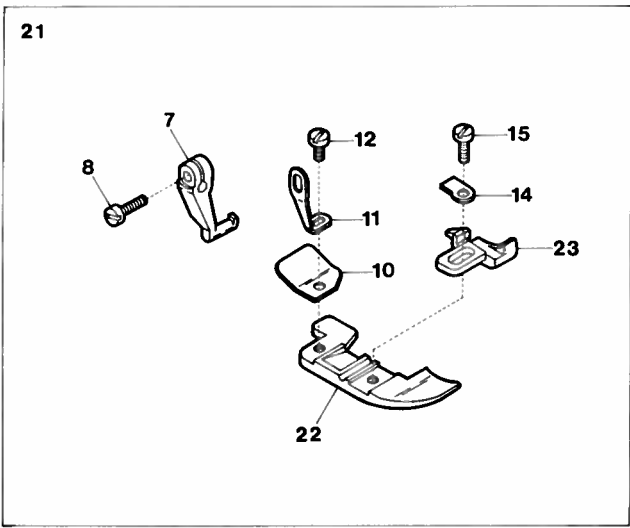

<u>Ref. No.</u>	<u>Parts No.</u>	<u>Description</u>	<u>品 名</u>	<u>Amt. Req.</u>
1	21204	Differential Feed Dog	前送り	1
2	21205	Main Feed Dog	後送り	1
3	528	Washer for 21727	ワッシャ	1
4	933	Rubber Cushion	埋メ座	2
5	932	Rubber Cushion	埋メ座	1
6	23094	Presser Foot, Complete Set	押工(組)	1
7	21938	Presser Foot Hinge	押工ヒンジ	1
8	4351	Screw for 21938	押工ヒンジ止ネジ	1
9	21196	Presser Foot (Lower)	押工(下)	1
10	34535	Presser Foot Chain Shield	空糸押工	1
11	21301	Presser Foot Stay	押工固定片	1
12	4236	Screw for 21301	押工固定片止ネジ	1
13	21202	Presser Foot Stitch Tongue	爪	1
14	21005	Presser Foot Hinge Spring	押工ヒンジバネ	1
15	4131	Screw for 21005	押工ヒンジバネ止ネジ	1
16	21197	Stitch Plate, Complete Set	針板(組)	1
17	21194	Stitch Plate	針板	1
18	21216	Stitch Plate Tongue	針板爪	1
19	4204	Screw for 21216	針板爪止ネジ	1
20	21195	Auxiliary Feed Dog	小送り	1
21	23082	Presser Foot, Complete Set	押工(組)	1
22	21201	Presser Foot (Lower)	押工(下)	1
23	21218	Presser Foot Stitch Tongue	爪	1
24	21217	Stitch Plate, Complete Set	針板(組)	1
25	21215	Stitch Plate	針板	1
26	21220	Auxiliary Feed Dog	小送り	1

Z5020-X4,X4-3,X4-4,X5-4

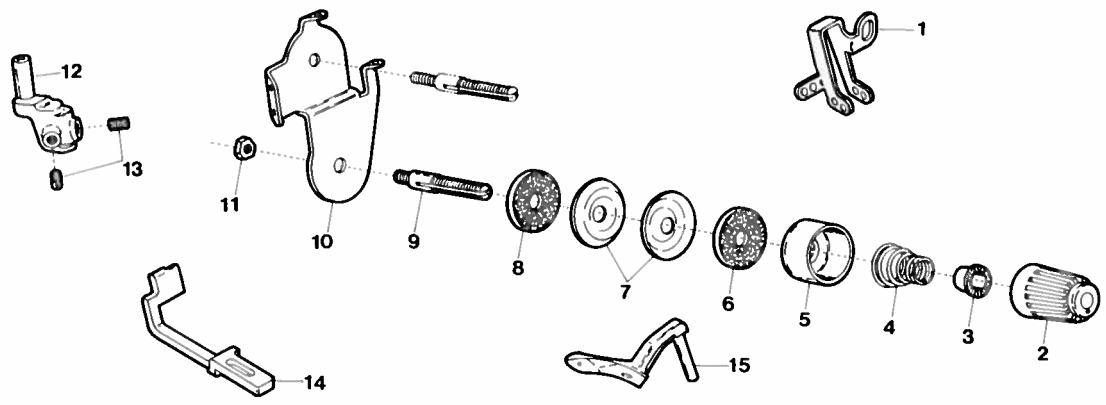

Z5020-X4,X4-4,X5-4

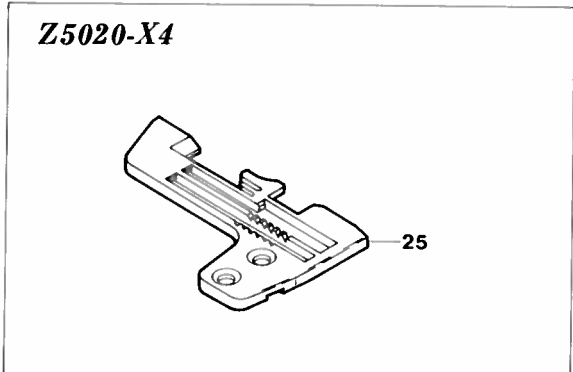
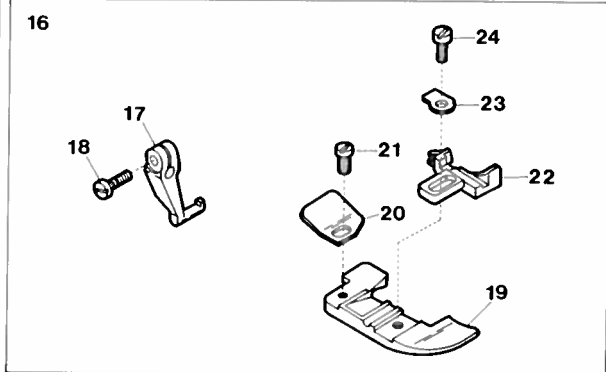

Z5020-X4-4,X5-4

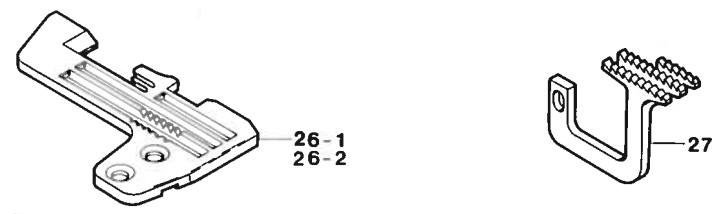

Z5020-X4-3

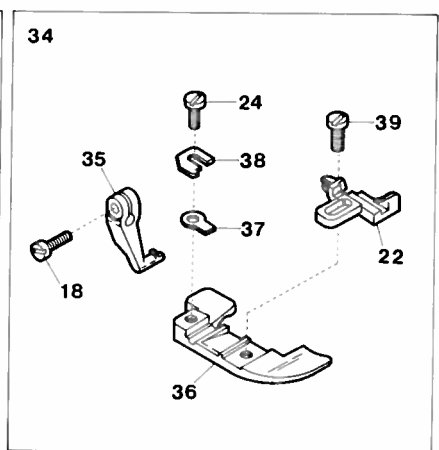
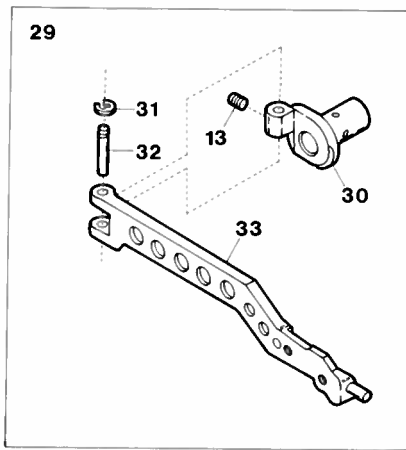
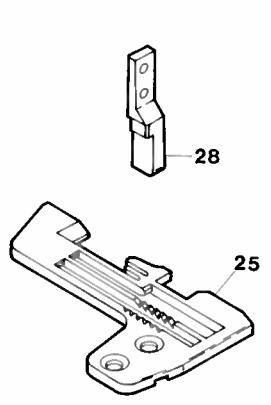

Ref. No.	Parts No.	Description	品名	Amt. Req.
1	23467	Needle Thread Eyelet	針糸道	1
2	20104	Thread Tension Spring Cap	糸調子バネキャップ(上)	1
3	33890	Tension Spring Bushing	糸調子ナット回り止メ	1
4	30255	Tension Spring	糸調子バネ	1
5	20118	Thread Tension Spring Retainer	糸調子バネキャップ(下)	1
6	178	Felt for 31111	フェルト	1
7	31111	Tension Disc	糸調子皿	2
8	177	Felt for 31111	フェルト	1
9	4125	Tension Post	糸調子棒	1
10	20100	Tension Disc Eyelet for Needle Thread	調子台糸道	1
11	340	Nut for 4125	ナット	1
12	21893	Needle Clamp (X)	針止メ(X)	1
13	3637	Screw for Needle, 21018	止ネジ	3
14	21238	Needle Guard (Front)	針受ケ(前)	1
15	21754	Upper Looper	上ルーバ	1
16-1	23030	Presser Foot, Complete Set (X4, X4-4)	押工(組)(X4, X4-4)	1
16-2	23032	" " " " (X5-4)	" (X5-4)	1
17	21938	Presser Foot Hinge	押エヒンジ	1
18	4351	Screw for 21938, 21242	押エヒンジ止ネジ	1
19	21967	Presser Foot (Lower)	押工(下)	1
20	34535	Presser Foot Chain Shield	空糸押工	1
21	1228	Screw for 34535	空糸押工止ネジ	1
22-1	21870	Presser Foot Stitch Tongue (X4)	爪(X4)	1
22-2	22600	" " " " (X5)	"(X5)	1
23	21005	Presser Foot Hinge Spring	押エヒンジバネ	1
24	4131	Screw for 21005, 22519	止ネジ	1
25	21781	Stitch Plate (X4, X4-3)	針板(X4, X4-3)	1
26-1	22607	Stitch Plate (X4-4)	針板(X4-4)	1
26-2	22601	" " (X5-4)	"(X5-4)	1
27	22608	Differential Feed Dog	前送り	1
28	20663	Dust Proof-off Block	防塵ブロック	1
29	22268	Presser Arm, Complete Set	押工腕(組)	1
30	22255	Presser Arm Hinge	押工腕ヒンジ	1
31	34293	Retaining Ring	ストップリング	1
32	21018	Presser Arm Hinge Pin	押工腕ヒンジピン	1
33	22253	Presser Arm	押工腕	1
34	22525	Presser Foot, Complete Set	押工(組)	1
35	21242	Presser Foot Hinge	押エヒンジ	1
36	21240	Presser Foot (Lower)	押工(下)	1
37	21243	Presser Foot Hinge Spring	押エヒンジバネ	1
38	22519	Presser Foot Adjusting Plate	押工調節片	1
39	4138	Screw for 21870	爪止ネジ	1

Z5020-Y, Y-3,

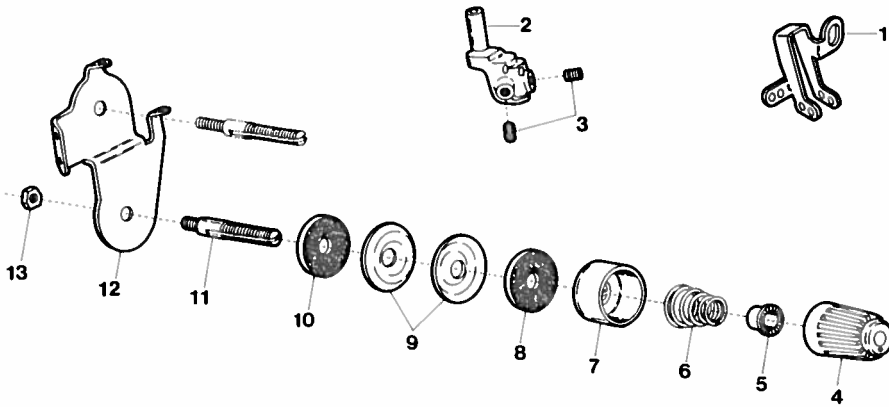

Z5020-Y

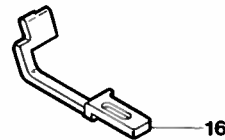
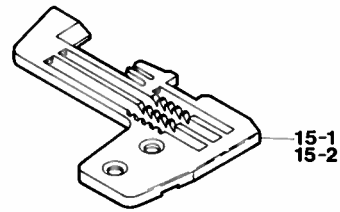
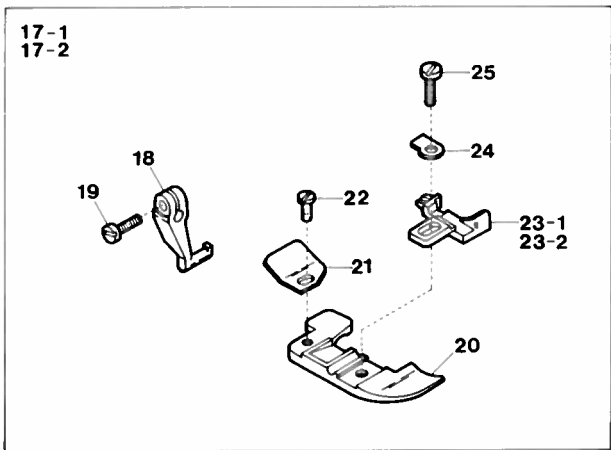

Z5020-Y-3

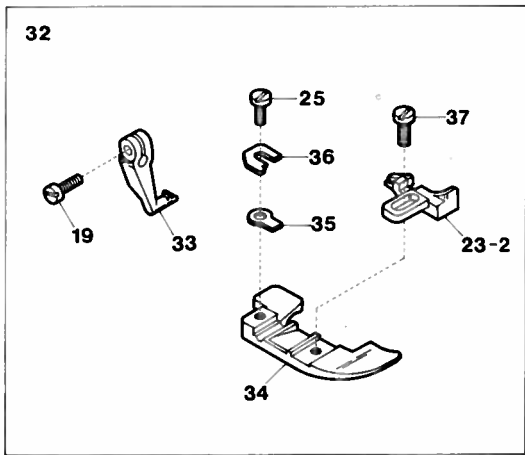
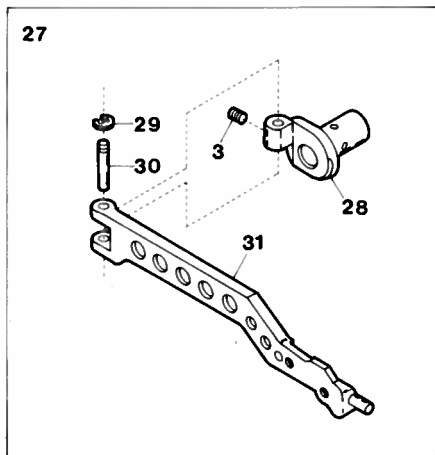

Ref. No.	Parts No.	Description	品名	Amt. Req.
1	23467	Needle Thread Eyelet	針糸道	1
2	21891	Needle Clamp (Y)	針止メ(Y)	1
3	3637	Screw for Needle, 21018	止ネジ	3
4	20104	Thread Tension Spring Cap	糸調子バネキャップ(上)	1
5	33890	Tension Spring Bushing	糸調子ナット回り止メ	1
6	30255	Tension Spring	糸調子バネ	1
7	20118	Thread Tension Spring Retainer	糸調子バネキャップ(下)	1
8	178	Felt for 31111	フェルト	1
9	31111	Tension Disc	糸調子皿	2
10	177	Felt for 31111	フェルト	1
11	4125	Tension Post	糸調子棒	1
12	20100	Tension Disc Eyelet for Needle Thread	調子台糸道	1
13	340	Nut for 4125	ナット	1
14	21754	Upper Looper	上ルーバ	1
15-1	21786	Stitch Plate (Y5)	針板(Y5)	1
15-2	21787	" (Y6)	" (Y6)	1
16	21105	Needle Guard (Front)	針受ケ(前)	1
17-1	23034	Presser Foot, Complete Set (Y5)	押工(組)(Y5)	1
17-2	23036	" " (Y6)	" (Y6)	1
18	21938	Presser Foot Hinge	押工ヒンジ	1
19	4351	Screw for 21938, 21242	押工ヒンジ止ネジ	1
20	21967	Presser Foot (Lower)	押工(下)	1
21	34535	Presser Foot Chain Shield	空糸押工	1
22	1228	Screw for 34535	空糸押工止ネジ	1
23-1	21864	Presser Foot Stitch Tongue (Y5)	爪(Y5)	1
23-2	21865	" " (Y6)	" (Y6)	1
24	21005	Presser Foot Hinge Spring	押工ヒンジバネ	1
25	4131	Screw for 21005, 22519	止ネジ	1
26	20663	Dust Proof-off Block	防塵ブロック	1
27	22268	Presser Arm Complete Set	押工腕(組)	1
28	22255	Presser Arm Hinge	押工腕ヒンジ	1
29	34293	Retaining Ring	ストップリング	1
30	21018	Presser Arm Hinge Pin	押工腕ヒンジピン	1
31	22253	Presser Arm	押工腕	1
32	22523	Presser Foot, Complete Set (Y6-3)	押工(組)(Y6-3)	1
33	21242	Presser Foot Hinge	押工ヒンジ	1
34	21240	Presser Foot (Lower)	押工(下)	1
35	21243	Presser Foot Hinge Spring	押工ヒンジバネ	1
36	22519	Presser Foot Adjusting Plate	押工調節片	1
37	4138	Screw for 21865	爪止ネジ	1

Z5021-A,A-3

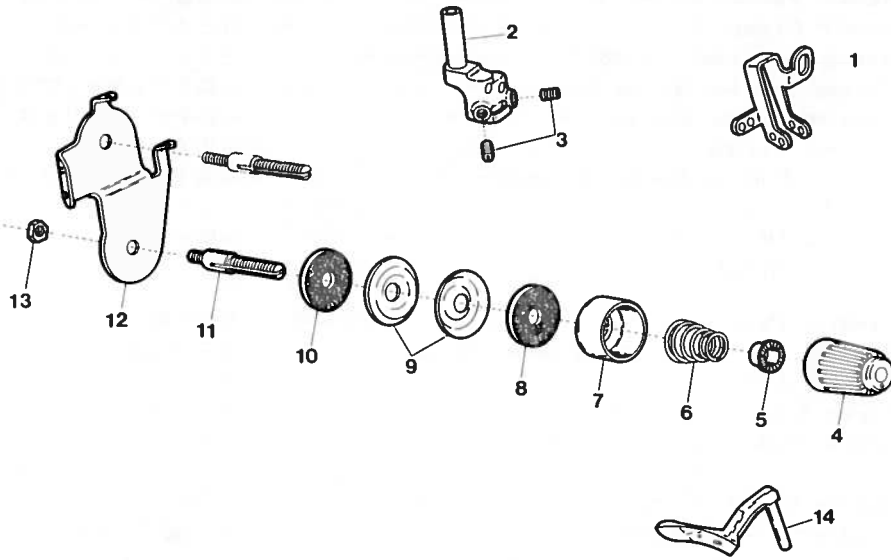

Z5021-A

18-1
18-2

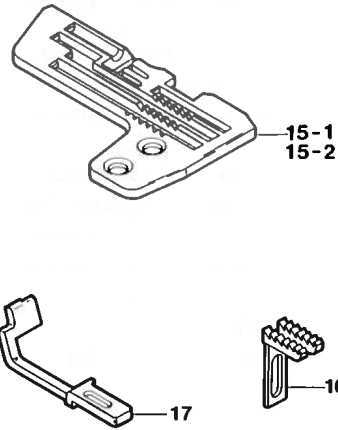
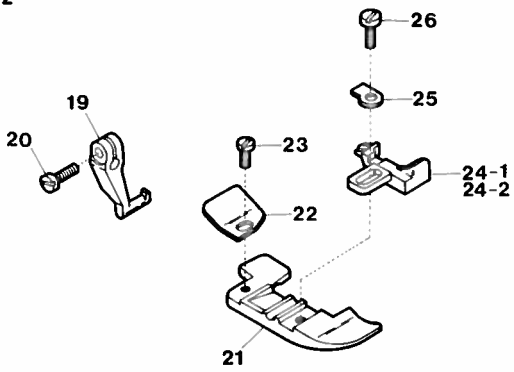

Z5021-A-3

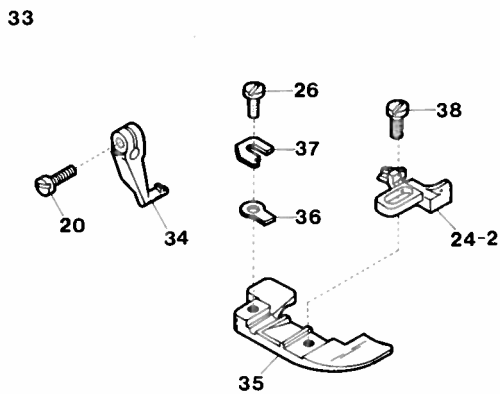
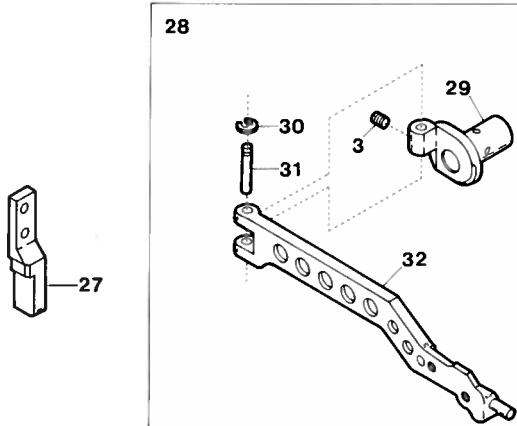

Ref. No.	Parts No.	Description	品 名	Amt. Req.
1	23467	Needle Thread Eyelet	針糸道	1
2	21890	Needle Clamp (A)	針止メ(A)	1
3	3637	Screw for Needle, 21018	止ネジ	3
4	20104	Thread Tension Spring Cap	糸調子バネキャップ(上)	1
5	33890	Tensing Bushing	糸調子ナット回り止メ	1
6	30255	Tension Spring	糸調子バネ	1
7	20118	Thread Tension Spring Retainer	糸調子バネキャップ(下)	1
8	178	Felt for 31111	フェルト	1
9	31111	Tension Disc	糸調子皿	2
10	177	Felt for 31111	フェルト	1
11	4125	Tension Post	糸調子棒	1
12	20100	Tension Disc Eyelet for Needle Thread	調子台糸道	1
13	340	Nut for 4125	ナット	1
14	21758	Upper Looper	上ルーバ	1
15-1	21798	Stitch Plate (A6)	針板(A6)	1
15-2	21799	" (A7)	" (A7)	1
16	21151	Auxiliary Feed Dog	小送り	1
17	21147	Needle Guard (Front)	針受ケ(前)	1
18-1	23076	Presser Foot, Complete Set (A6)	押エ(組)(A6)	1
18-2	23078	" " (A7)	" (A7)	1
19	21938	Presser Foot Hinge	押エヒンジ	1
20	4351	Screw for 21938, 21242	押エヒンジ止ネジ	1
21	22054	Presser Foot (Lower)	押エ(下)	1
22	34535	Presser Foot Chain Shield	空糸押エ	1
23	1228	Screw for 34535	空糸押エ止ネジ	1
24-1	21868	Presser Foot Stitch Tongue (A6)	爪(A6)	1
24-2	21869	" " (A7)	" (A7)	1
25	21005	Presser Foot Hinge Spring	押エヒンジバネ	1
26	4131	Screw for 21005, 22519	止ネジ	1
27	20663	Dust Proof-off Block	防塵ブロック	1
28	22268	Presser Arm, Complete Set	押エ腕(組)	1
29	22255	Presser Arm Hinge	押エ腕ヒンジ	1
30	34293	Retaining Ring	ストップリング	1
31	21018	Presser Arm Hinge Pin	押エ腕ヒンジピン	1
32	22253	Presser Arm	押エ腕	1
33	22527	Presser Foot, Complete Set (A7-3)	押エ(組)(A7-3)	1
34	21242	Presser Foot Hinge	押エヒンジ	1
35	21245	Presser Foot (Lower)	押エ(下)	1
36	21243	Presser Foot Hinge Spring	押エヒンジバネ	1
37	22519	Presser Foot Adjusting Plate	押エ調節板	1
38	4138	Screw for 21869	爪止ネジ	1

Z5025-X4,X4-4,Y5,Y6

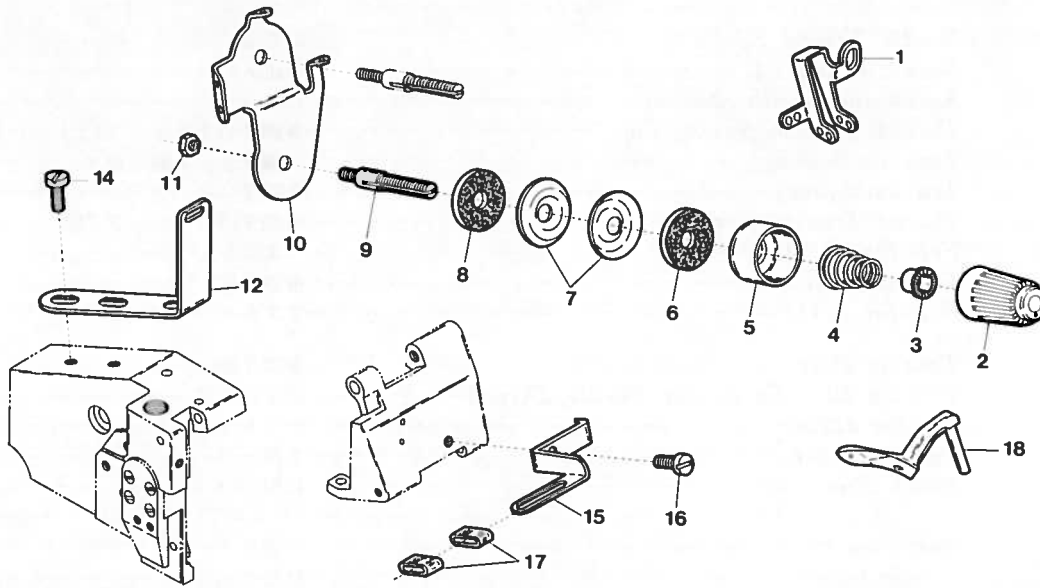

Z5025-X4,X4-4,X5-4

19-1
19-2

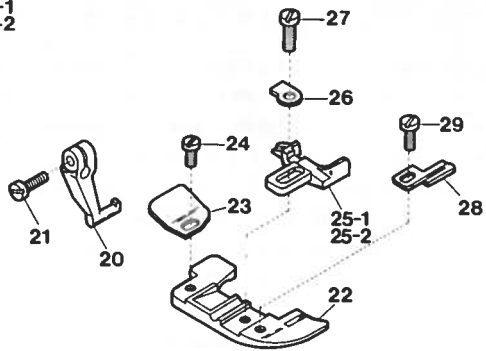

Z5025-X4

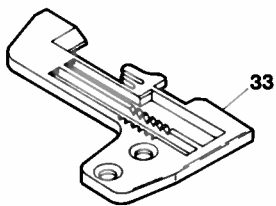

Z5025-X4-4,X5-4

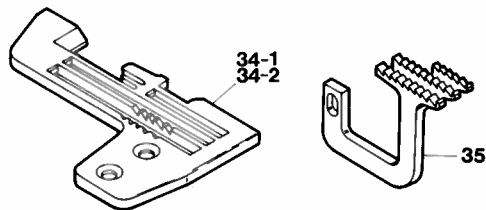

Z5025-Y5,Y6

36-1
36-2

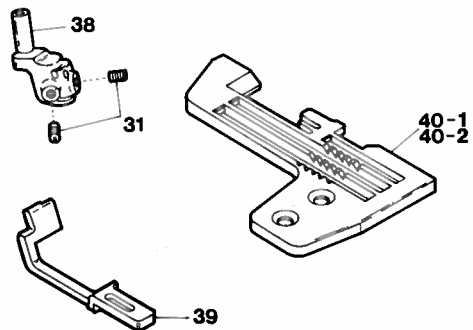
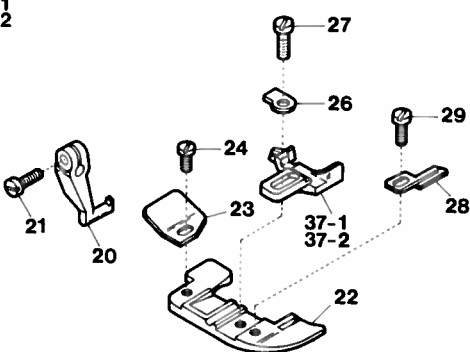

Ref. No.	Parts No.	Description	品 名	Amt. Req.
1	23467	Needle Thread Eyelet	針糸道	1
2	20104	Thread Tension Spring Cap	糸調子バネキャップ(上)	1
3	33890	Tension Spring Bushing	糸調子ナット回り止メ	1
4	30255	Tension Spring	糸調子バネ	1
5	20118	Thread Tension Spring Retainer	糸調子バネキャップ(下)	1
6	178	Felt for 31111	フェルト	1
7	31111	Tension Disc	糸調子皿	2
8	177	Felt for 31111	フェルト	1
9	4125	Tension Post	糸調子棒	1
10	20100	Tension Disc Eyelet for Needle Thread	調子台糸道	1
11	340	Nut for 4125	ナット	1
12	22248	Tape Guide (Upper)	テープガイド(上)	1
13				
14	9150	Screw for 22248	テープガイド(上)止ネジ	2
15	22249	Tape Guide (Lower)	テープガイド(下)	1
16	1203	Screw for 22249	テープガイド(下)止ネジ	1
17	33738	Tape Guide Tube	テープ支エ	1
18	21754	Upper Looper	上ルーバ	1
19-1	23060	Presser Foot, Complete Set (X4)	押エ(組)(X4)	1
19-2	23062	" " (X5)	" (X5)	1
20	21938	Presser Foot Hinge	押エヒンジ	1
21	4351	Screw for 21938	押エヒンジ止ネジ	1
22	22064	Presser Foot (Lower)	押エ(下)	1
23	34535	Presser Foot Chain Shield	空糸押エ	1
24	1228	Screw for 34535	空糸押エ止ネジ	1
25-1	22605	Presser Foot Stitch Tongue (X4)	爪(X4)	1
25-2	22606	" " (X5)	" (X5)	1
26	21005	Presser Foot Hinge Spring	押エヒンジバネ	1
27	4131	Screw for 21005	押エヒンジバネ止ネジ	1
28	21165	Presser Foot Tape Guide	押エテープガイド	1
29	1230	Screw for 21165	押エテープガイド止ネジ	1
30	21893	Needle Clamp (X)	針止メ(X)	1
31	3637	Screw for Needle	針止ネジ	2
32	21238	Needle Guard (Front)	針受ケ(前)	1
33	21781	Stitch Plate (X4)	針板(X4)	1
34-1	22607	Stitch Plate (X4-4)	針板(X4-4)	1
34-2	22601	" (X5-4)	" (X5-4)	1
35	22608	Differential Feed Dog	前送り	1
36-1	23064	Presser Foot, Complete Set (Y5)	押エ(組)(Y5)	1
36-2	23066	" " (Y6)	" (Y6)	1
37-1	21866	Presser Foot Stitch Tongue (Y5)	爪(Y5)	1
37-2	21867	" " (Y6)	" (Y6)	1
38	21891	Needle Clamp (Y)	針止メ(Y)	1
39	21105	Needle Guard (Front)	針受ケ(前)	1
40-1	21786	Stitch Plate (Y5)	針板(Y5)	1
40-2	21787	" (Y6)	" (Y6)	1

Z5026,5027(1)

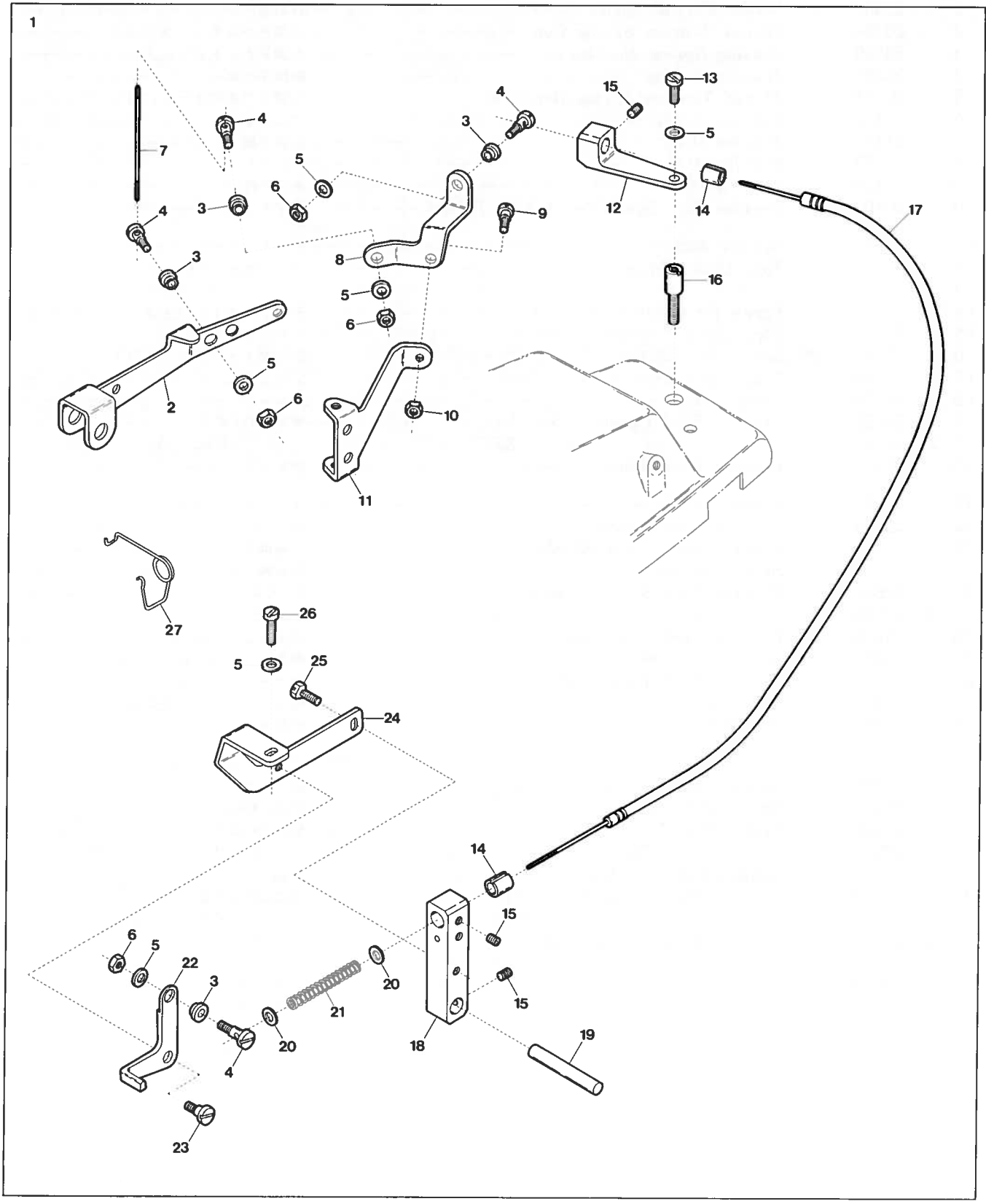

Ref. No.	Parts No.	Description	品 名	Amt. Req.
1	22987	Wire Lifting Mechanism, Complete Set	WL装置(組)	1
2	22960	Presser Foot Lifter Lever	押工揚ゲレバー	1
3	34979	Flexible Wire Clamp Bushing	ワイヤ止メブッシュ	4
4	6075	Screw for 34979	ワイヤ止メブッシュ止ネジ	4
5	538	Washer for 34979, 22964, 22961	ワッシャ	6
6	334	Nut for 34979	ナット	4
7	22971	Flexible Wire	ワイヤ	1
8	22968	Wire Pulling Arm	ワイヤ引き腕	1
9	6150	Screw for 22968	ワイヤ引き腕止ネジ	1
10	347	Nut for 22968	ナット	1
11	22967	Presser Foot Lifter Lever Stopper	押工揚ゲストッパ	1
12	22964	Flexible Wire Stay (Rear)	ワイヤ支エ(後)	1
13	1175	Screw for 22964	ワイヤ支エ(後)止ネジ	1
14	22947	Flexible Wire Stay Bushing	ワイヤ支エブッシュ	2
15	3638	Screw for 22947, 22981	止ネジ	3
16	4132	Screw for Top Cover	上カバー止ネジ	1
17	22972	Flexible Wire Unit	ワイヤ(組)	1
18	22963	Flexible Wire Stay (Front)	ワイヤ支エ(前)	1
19	22981	Flexible Wire Stay (Front) Shaft	ワイヤ支エ(前)取付軸	1
20	531	Washer for 22966	ワッシャ	2
21	22966	Flexible Wire Return Spring	ワイヤ戻シバネ	1
22	22962	Ruffling Presser & Fabric Presser Lifting Lever	ラフリング押工揚ゲレバー	1
23	4100	Screw for 22962	ラフリング押工揚ゲレバー止ネジ	1
24	22961	Ruffling Presser Lifting Lever Support	ラフリング押工揚ゲレバー取付台	1
25	7605	Screw for 22961	ラフリング押工揚ゲレバー取付台止ネジ	1
26	4353	Screw for 22961	ラフリング押工揚ゲレバー取付台止ネジ	1
27	20301	Intermediate Lever Spring	押工揚ゲ軸バネ	1

Z5026,5027(2)

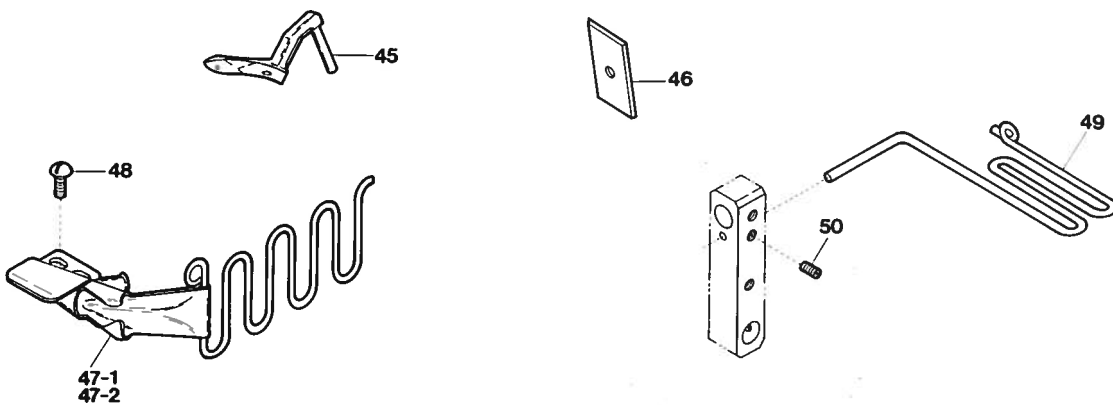
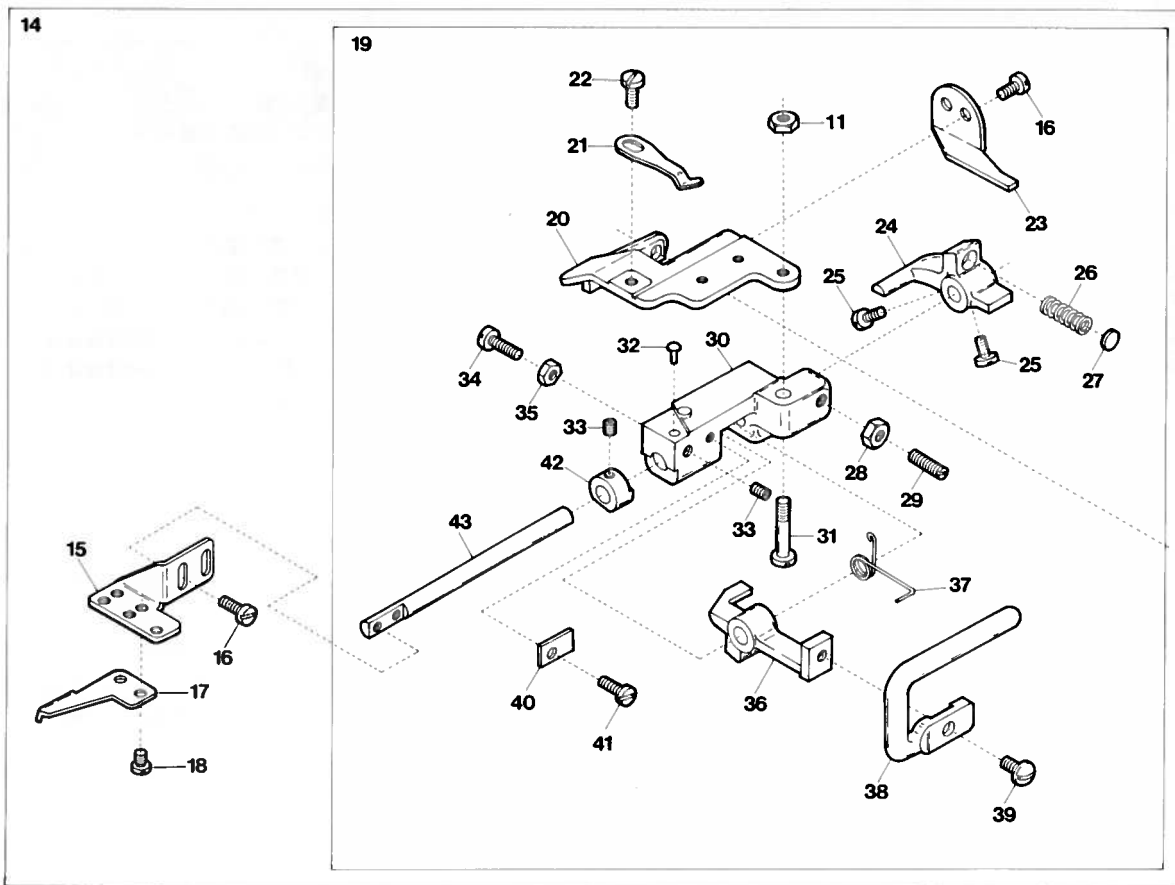
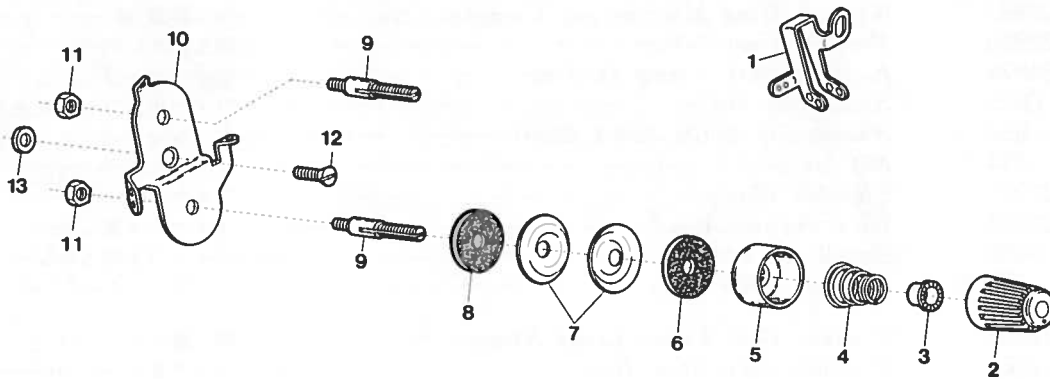

Ref. No.	Parts No.	Description	品名	Amt. Req.
1	23467	Needle Thread Eyelet	針糸道	1
2	20104	Thread Tension Spring Cap	糸調子バネキャップ(上)	1
3	33890	Tension Spring Bushing	糸調子ナット回り止メ	1
4	30255	Tension Spring	糸調子バネ	1
5	20118	Thread Tension Spring Retainer	糸調子バネキャップ(下)	1
6	178	Felt for 31111	フェルト	1
7	31111	Tension Disc	糸調子皿	2
8	177	Felt for 31111	フェルト	1
9	4125	Tension Post	糸調子棒	2
10	22970	Tension Disc Eyelet for Needle Thread	調子台糸道(大)	1
11	340	Nut for 4125, 20630	ナット	3
12	5345	Screw for 22970	調子台糸道止ネジ	1
13	538	Screw for 22970	スベーサ	1
14	24471	Piping Mechanism, Complete Set(2)	パイピング装置(組2)	1
15	22976	Folder Support	定規取付台	1
16	5036	Screw for 22976, 20631	止ネジ	4
17	22957	Fabric Presser	布押工	1
18	4401	Screw for 22957	布押工止ネジ	2
19	24470	Piping Mechanism, Complete Set(1)	パイピング装置(組1)	1
20	20611	Shaft Bracket Holder	ブラケット取付台	1
21	33397	Bracket Spring Plate	ブラケット止メバネ	1
22	7006	Screw for 33397	ブラケット止メバネ止ネジ	1
23	20631	Shaft Bracket Support	ブラケット受ケ	1
24	24463	Shaft Lever	布押エレバー	1
25	7302	Screw for 24463	布押エレバー止ネジ	2
26	22977	Fabric Presser Spring	布押工バネ	1
27	519	Washer for 22977	ワッシャ	1
28	355	Lock Nut for 3556	ロックナット	1
29	3556	Adjusting Screw for 22977	布押工バネ調節ネジ	1
30	20630	Shaft Bracket	ブラケット	1
31	6142	Screw for 20630	ブラケット止ネジ	1
32	632	Pin for 33397	ピン	1
33	3637	Screw for 632, 20616	止ネジ	2
34	7609	Positioning Screw for 20630	ブラケット位置決メネジ	1
35	335	Lock Nut for 7609	ロックナット	1
36	24462	Swing-out Handle Holder	布押工揚ゲハンドル取付台	1
37	24464	Swing-out Handle Holder Spring	ハンドル取付台バネ	1
38	24466	Swing-out Handle (for Fabric Presser)	布押工揚ゲハンドル	1
39	4591	Screw for 24466	布押工揚ゲハンドル止ネジ	1
40	24465	Swing-out Handle Holder Stopper	ハンドル取付台ストッパ	1
41	5000	Screw for 24465	ハンドル取付台ストッパ止ネジ	1
42	20616	Stopper Collar	ストッパカラー	1
43	33394	Shaft (for Fabric Presser)	布押工軸	1
44	5043	Screw for 20611	ブラケット取付台止ネジ	2
45	21754	Upper Looper	上ルーパー	1
46	24343	Lower Knife Clamp	下メス押工	1
47-1	20686	Folder (A)(Tape Width 20mm)	定規(A)(テープ幅20mm)	1
47-2	20688	" " (for Jersey)	" " (ジャージー用)	1
48	1330	Screw for 20686, 20688	定規止ネジ	2
49	22982	Tape Guide	テープガイド	1
50	3638	Screw for 22982	テープガイド止ネジ	1

Z5026,5027(3)



Z5026-X4,5027-X4

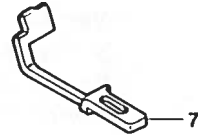
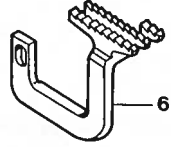
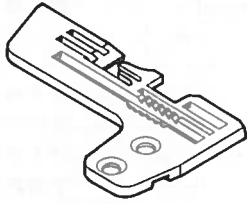
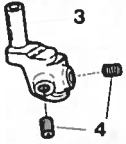

Z5026-X4

8

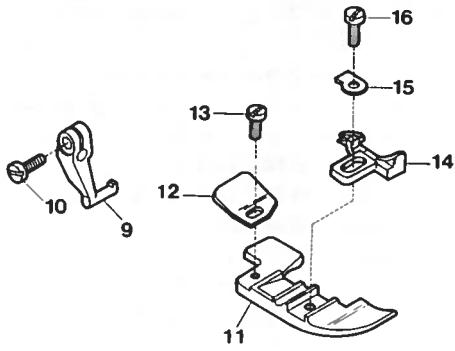

Z5027-X4

17

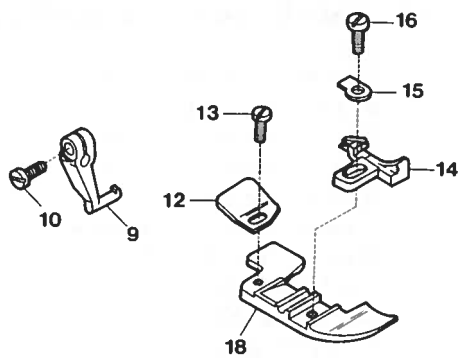

Z5026-Y5,5027-Y5

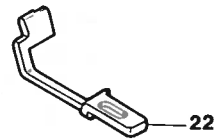
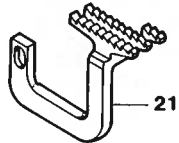
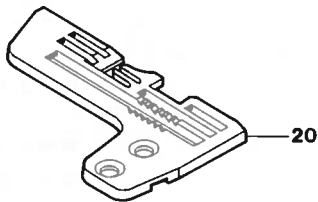
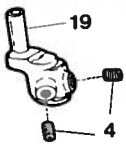

Z5026-Y5

23

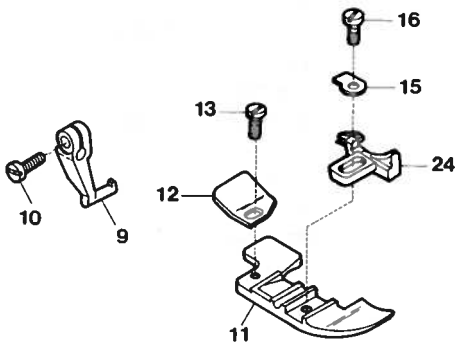

Z5027-Y5

25

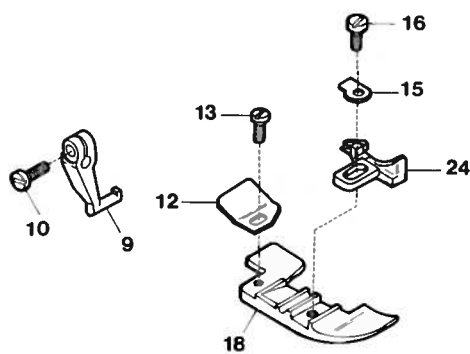

Ref. No.	Parts. No.	Description	品 名	Amt. Req.
1	22020	Main Feed Dog	後送り	1
2	22956	Auxiliary Feed Dog	小送り	1
3	21893	Needle Clamp (X)	針止メ	1
4	3637	Screw for Needle	針止ネジ	2
5	22952	Stitch Plate (X4)	針板	1
6	22975	Differential Feed Dog	前送り	1
7	21238	Needle Guard (Front)	針受ケ(前)	1
8	23112	Presser Foot, Complete Set (Z5026-X4)	押工(組)	1
9	21938	Presser Foot Hinge	押エヒンジ	1
10	4351	Screw for 21938	押エヒンジ止ネジ	1
11	22945	Presser Foot (Lower)	押工(下)	1
12	34535	Presser Foot Chain Shield	空糸押工	1
13	1228	Screw for 34535	空糸押工止ネジ	1
14	22948	Presser Foot Stitch Tongue	爪	1
15	21005	Presser Foot Hinge Spring	押エヒンジバネ	1
16	4131	Screw for 21005	押エヒンジバネ止ネジ	1
17	23124	Presser Foot, Complete Set (Z5027-X4)	押工(組)	1
18	22980	Presser Foot (Lower)	押工(下)	1
19	21891	Needle Clamp (Y)	針止メ	1
20	22954	Stitch Plate (Y5)	針板	1
21	22959	Differential Feed Dog	前送り	1
22	21105	Needle Guard (Front)	針受ケ(前)	1
23	23096	Presser Foot, Complete Set (Z5026-Y5)	押工(組)	1
24	22950	Presser Foot Stitch Tongue	爪	1
25	23136	Presser Foot, Complete Set (Z5027-Y5)	押工(組)	1

Z5037

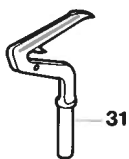
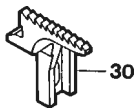
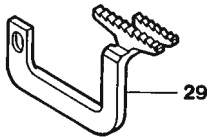
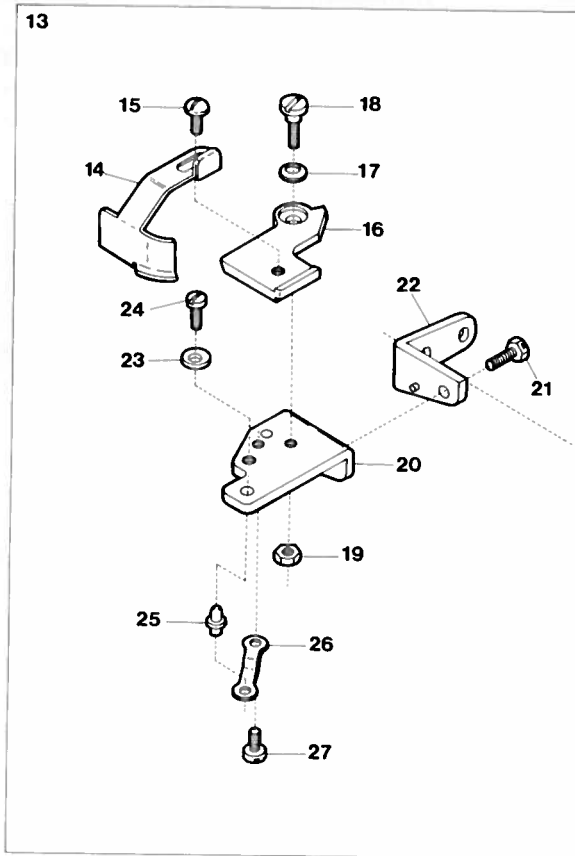
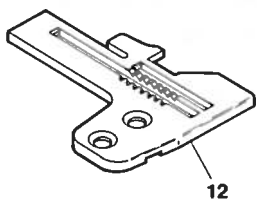
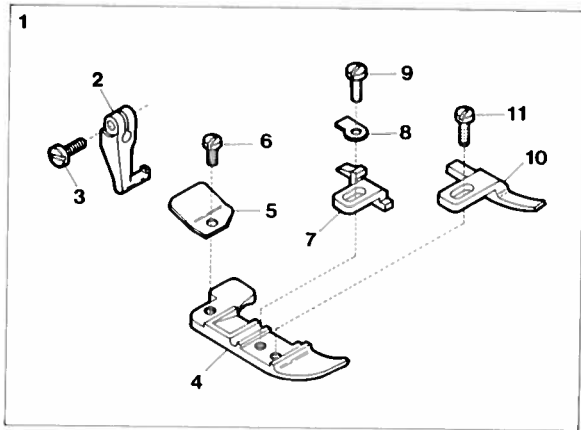

Ref. No.	Parts No.	Description	品 名	Amt. Req.
1	22817	Presser Foot, Complete Set (05)	押工(組)	1
2	21938	Presser Foot Hinge	押工ヒンジ	1
3	4351	Screw for 21938	押工ヒンジ止ネジ	1
4	22814	Presser Foot (Lower)	押工(下)	1
5	34535	Presser Foot Chain Shield	空糸押工	1
6	1228	Screw for 34535	空糸押工止ネジ	1
7	22816	Presser Foot Stitch Tongue	爪	1
8	21005	Presser Foot Hinge Spring	押工ヒンジバネ	1
9	4131	Screw for 21005	押工ヒンジバネ止ネジ	1
10	22815	Fabric Guide	布押工	1
11	4236	Screw for 22815	布押工止ネジ	1
12	22811	Stitch Plate	針板	1
13	22430	Edge Guide Complete Set	当て定規(組)	1
14	22432	Edge Guide	当て定規	1
15	1330	Screw for 22432	当て定規止ネジ	1
16	22431	Edge Guide Swing-out Lever	スイングアウトレバー	1
17	172	Spring Washer for 22431	スプリングワッシャー	1
18	4150	Screw for 22431	スイングアウトレバー止ネジ	1
19	334	Nut for 22431	ナット	1
20	22434	Edge Guide Swing-out Lever Holder	スイングアウトレバー取付台	1
21	5506	Screw for 22434	スイングアウトレバー取付台止ネジ	1
22	22433	Edge Guide Swing-out Lever Holder Support	定規取付台	1
23	22437	Edge Guide Swing-out Lever Stopper	スイングアウトレバーストッパ	1
24	7616	Screw for 22437	スイングアウトレバーストッパ止ネジ	1
25	22435	Edge Guide Positioning Pin	定規固定ピン	1
26	22436	Edge Guide Positioning Pin Holder Spring	定規固定ピン押エバネ	1
27	1227	Screw for 22436	定期固定ピン押エバネ止ネジ	1
28	4440	Screw for 22433	定規取付台止ネジ	2
29	22812	Differential Feed Dog	前送り	1
30	22813	Main Feed Dog	後送り	1
31	22822	Lower Looter	下ルーバ	1
32	21752	Upper Spreader	上スプレダ	1

Z5045,5046(1)

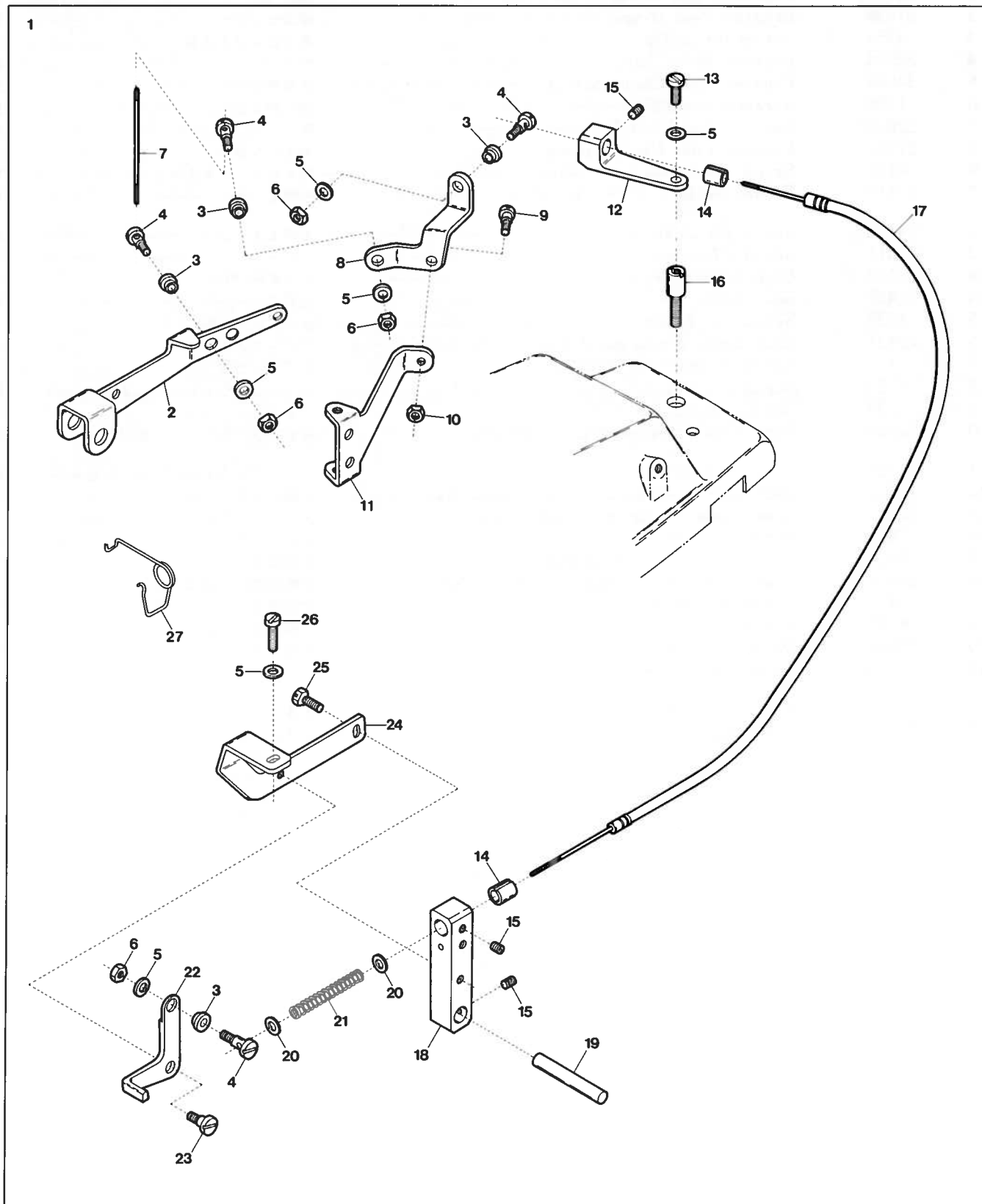

Ref. No.	Parts No.	Description	品 名	Amt. Req.
1	22987	Wire Lifting Mechanism, Complete Set	WL 装置(組)	1
2	22960	Presser Foot Lifter Lever	押工揚ゲレバー	1
3	34979	Flexible Wire Clamp Bushing	ワイヤ止メブッシュ	4
4	6075	Screw for 34979	ワイヤ止メブッシュ止ネジ	4
5	538	Washer for 34979, 22964, 22961	ワッシャ	6
6	334	Nut for 34979	ナット	4
7	22971	Flexible Wire	ワイヤ	1
8	22968	Wire Pulling Arm	ワイヤ引き腕	1
9	6150	Screw for 22968	ワイヤ引き腕止ネジ	1
10	347	Nut for 22968	ナット	1
11	22967	Presser Foot Lifter Lever Stopper	押工揚ゲストップバ	1
12	22964	Flexible Wire Stay (Rear)	ワイヤ支エ(後)	1
13	1175	Screw for 22964	ワイヤ支エ(後)止ネジ	1
14	22947	Flexible Wire Stay Bushing	ワイヤ支エブッシュ	2
15	3638	Screw for 22947, 22981	止ネジ	3
16	4132	Screw for Top Cover	上カバー止ネジ	1
17	22972	Flexible Wire Unit	ワイヤ(組)	1
18	22963	Flexible Wire Stay (Front)	ワイヤ支エ(前)	1
19	22981	Flexible Wire Stay (Front) Shaft	ワイヤ支エ(前)取付軸	1
20	531	Washer for 22966	ワッシャ	2
21	22966	Flexible Wire Return Spring	ワイヤ戻シバネ	1
22	22962	Ruffling Presser & Fabric Presser Lifting Lever	ラフリング押工揚ゲレバー	1
23	4100	Screw for 22962	ラフリング押工揚ゲレバー止ネジ	1
24	22961	Ruffling Presser Lifting Lever Support	ラフリング押工揚ゲレバー取付台	1
25	7605	Screw for 22961	ラフリング押工揚ゲレバー取付台止ネジ	1
26	4353	Screw for 22961	ラフリング押工揚ゲレバー取付台止ネジ	1
27	20301	Intermediate Lever Spring	押工揚ゲ軸バネ	1

Z5045,5046(2)

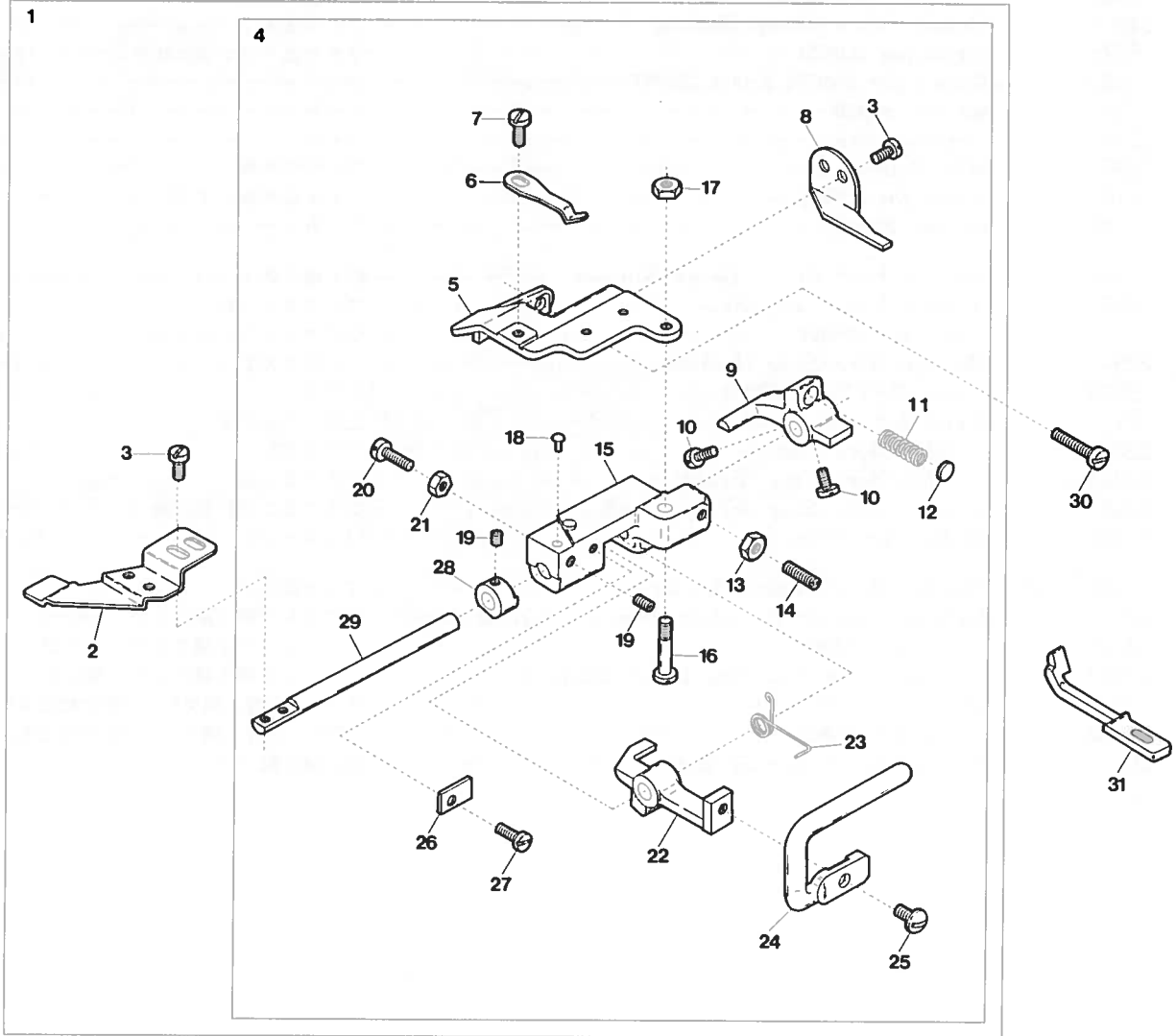

Z5045

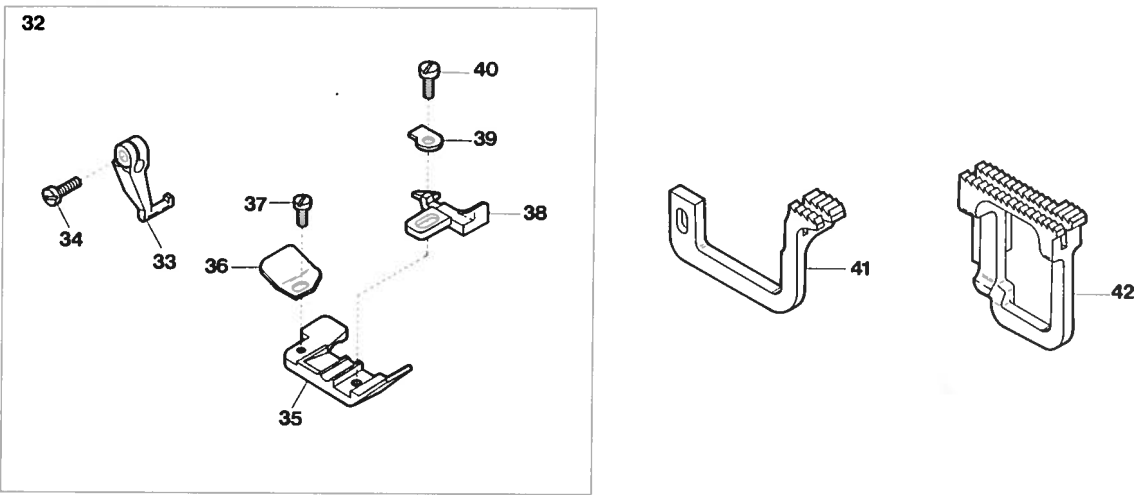

Ref. No.	Parts No.	Description	品 名	Amt. Req.
1	24461	Ruffling Mechanism, Complete Set(2)	ラフリング装置(組2)	1
2	20612	Ruffling Presser	ラフリング押エ	1
3	5036	Screw for 20612, 20631	止ネジ	4
4	24460	Ruffling Mechanism, Complete Set(1)	ラフリング装置(組1)	1
5	20611	Shaft Bracket Holder	ブラケット取付台	1
6	33397	Bracket Spring Plate	ブラケット止メバネ	1
7	7006	Screw for 33397	ブラケット止メバネ止ネジ	1
8	20631	Shaft Bracket Support	ブラケット受ケ	1
9	24463	Shaft Lever	ラフリング押エ軸レバー	1
10	7302	Screw for 24463	ラフリング押エ軸レバー止ネジ	2
11	33398	Ruffling Presser Spring	ラフリング押エバネ	1
12	519	Washer for 33398	ワッシャー	1
13	355	Lock Nut for 3556	ロックナット	1
14	3556	Adjusting Screw for 33398	ラフリング押エバネ調節ネジ	1
15	20630	Shaft Bracket	ブラケット	1
16	6142	Screw for 20630	ブラケット止ネジ	1
17	340	Nut for 20611	ナット	1
17	632	Pin for 33397	ピン	1
19	3637	Screw for 632, 20616	止ネジ	2
20	7609	Positioning Screw for 20630	ブラケット位置決メネジ	1
21	335	Lock Nut for 7609	ロックナット	1
22	24462	Swing-out Handle Holder	押エ揚ゲハンドル取付台	1
23	24464	Swing-out Handle Holder Spring	ハンドル取付台バネ	1
24	24466	Swing-out Handle (for Ruffling Presser)	押エ揚ゲハンドル	1
25	4591	Screw for 24466	押エ揚ゲハンドル止ネジ	1
26	24465	Swing-out Handle Holder Stopper	ハンドル取付台ストッパ	1
27	5000	Screw for 24465	ハンドル取付台ストッパ止ネジ	1
28	20616	Stopper Collar	ストッパカラー	1
29	33394	Shaft (for Ruffling Presser)	ラフリング押エ軸	1
30	5043	Screw for 20611	ブラケット取付台止ネジ	2
31	20676	Needle Guard (Front)	針受ケ(前)	1
32	23084	Presser Foot, Complete Set (O4)	押エ(組)	1
33	21938	Presser Foot Hinge	押エヒンジ	1
34	4351	Screw for 21938	押エヒンジ止ネジ	1
35	22153	Presser Foot (Lower)	押エ(下)	1
36	34535	Presser Foot Chain Shield	空糸押エ	1
37	1228	Screw for 34535	空糸押エ止ネジ	1
38	21876	Presser Foot Stitch Tongue	爪	1
39	21005	Presser Foot Hinge Spring	押エヒンジバネ	1
40	4131	Screw for 21005	押エヒンジバネ止ネジ	1
41	21849	Differential Feed Dog	前送り	1
42	21843	Main Feed Dog	後送り	1

Z5046(3)

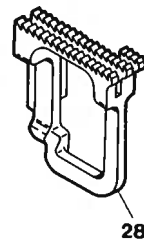
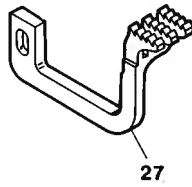
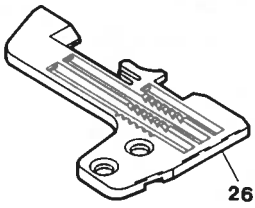
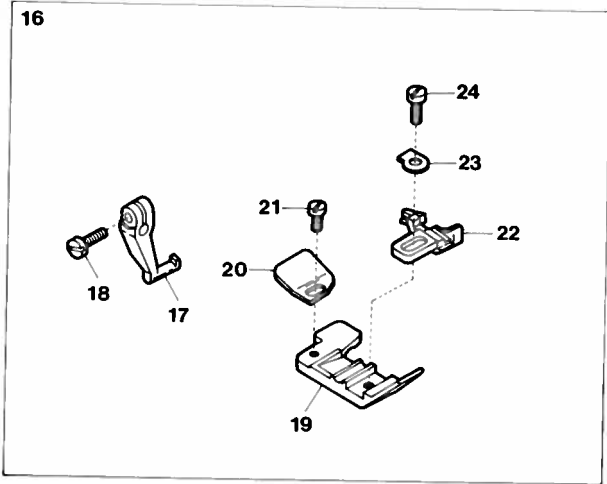
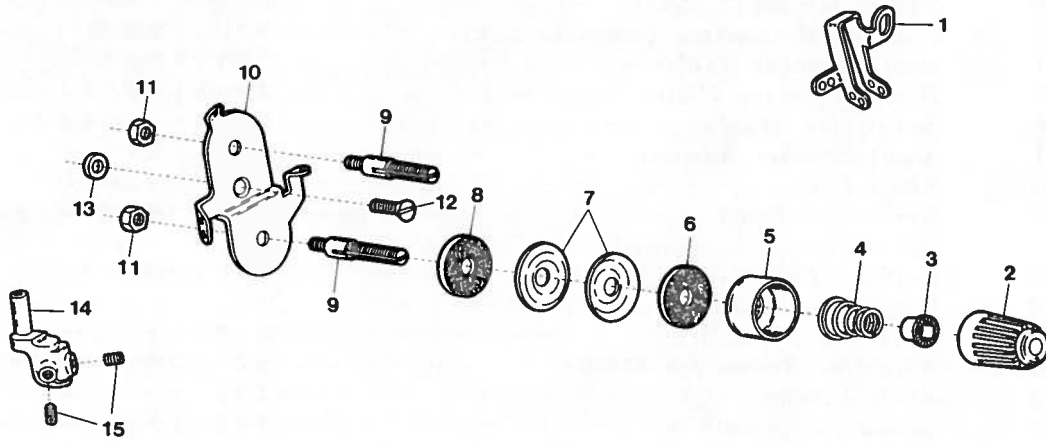

Ref. No.	Parts No.	Description	品 名	Amt. Req.
1	23467	Needle Thread Eyelet	針糸道	1
2	20104	Thread Tension Spring Cap	糸調子バネキャップ(上)	1
3	33890	Tension Spring Bushing	糸調子ナット回り止メ	1
4	30255	Tension Spring	糸調子バネ	1
5	20118	Thread Tension Spring Retainer	糸調子バネキャップ(下)	1
6	178	Felt for 31111	フェルト	1
7	31111	Tension Disc	糸調子皿	2
8	177	Felt for 31111	フェルト	1
9	4125	Tension Post	糸調子棒	2
10	22970	Tension Disc Eyelet for Needle Thread	調子台糸道	1
11	340	Nut for 4125	ナット	2
12	5345	Screw for 22970	調子台糸道止ネジ	1
13	538	Spacer for 22970	スペーサ	1
14	21891	Needle Clamp (Y)	針止メ	1
15	3637	Screw for Needle	針止ネジ	2
16	23086	Presser Foot, Complete Set (Y6)	押エ(組)	1
17	21938	Presser Foot Hinge	押エヒンジ	1
18	4351	Screw for 21938	押エヒンジ止ネジ	1
19	22153	Presser Foot (Lower)	押エ(下)	1
20	34535	Presser Foot Chain Shield	空糸押エ	1
21	1228	Screw for 34535	空糸押エ止ネジ	1
22	21879	Presser Foot Stitch Tongue	爪	1
23	21005	Presser Foot Hinge Spring	押エヒンジバネ	1
24	4131	Screw for 21005	押エヒンジバネ止ネジ	1
25	21754	Upper Looper	上ルーバ	1
26	21787	Stitch Plate	針板	1
27	21844	Differential Feed Dog	前送り	1
28	21845	Main Feed Dog	後送り	1

Z5056,5057(1)

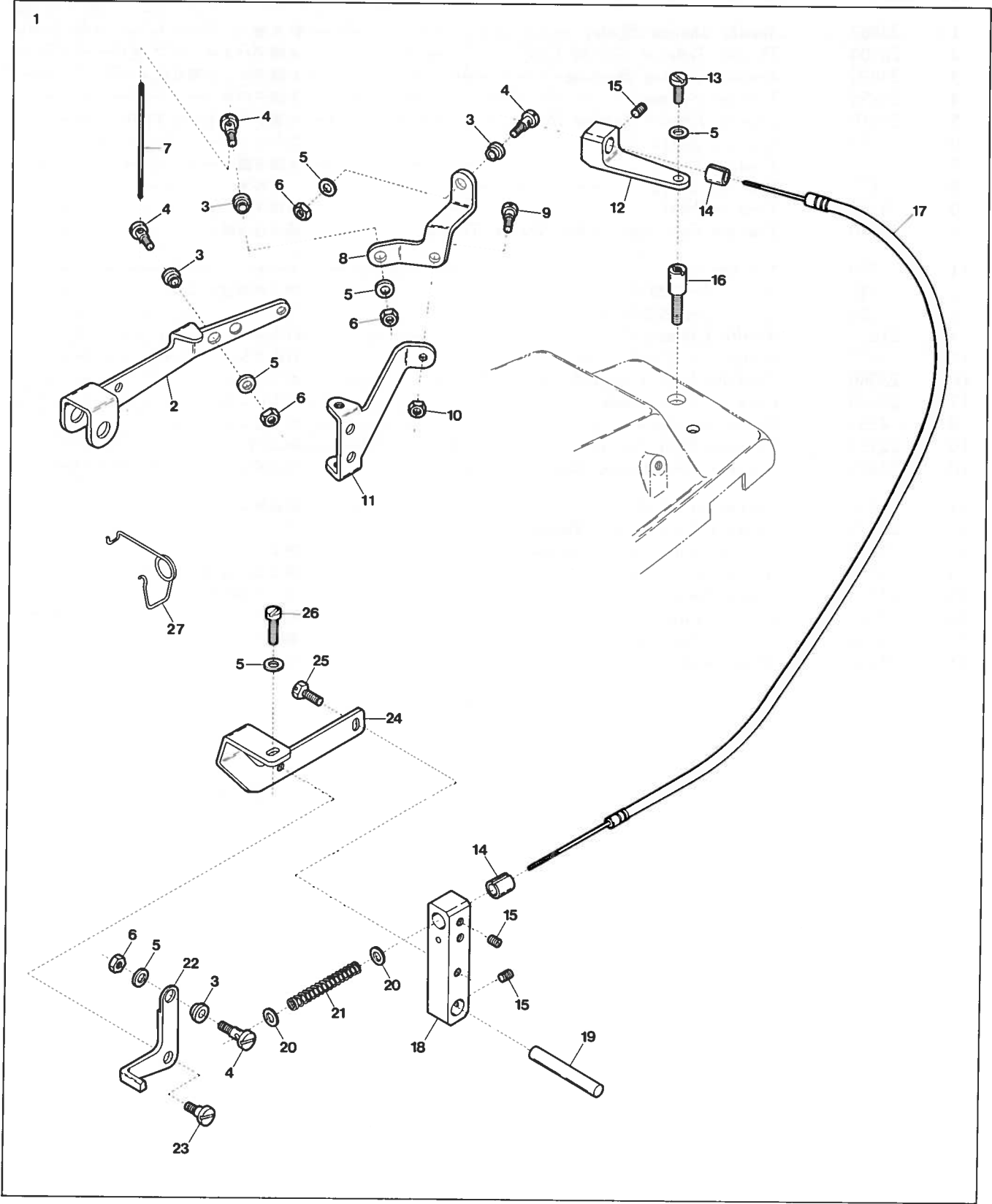

Ref. No.	Parts No.	Description	品 名	Amt. Req.
1	22987	Wire Lifting Mechanism, Complete Set	WL装置(組)	1
2	22960	Presser Foot Lifter Lever	押工揚ゲレバー	1
3	34979	Flexible Wire Clamp Bushing	ワイヤ止メブッシュ	4
4	6075	Screw for 34979	ワイヤ止メブッシュ止ネジ	4
5	538	Washer for 34979, 22964, 22961	ワッシャ	6
6	334	Nut for 34979	ナット	4
7	22971	Flexible Wire	ワイヤ	1
8	22968	Wire Pulling Arm	ワイヤ引き腕	1
9	6150	Screw for 22968	ワイヤ引き腕止ネジ	1
10	347	Nut for 22968	ナット	1
11	22967	Presser Foot Lifter Lever Stopper	押工揚ゲストッパ	1
12	22964	Flexible Wire Stay (Rear)	ワイヤ支工(後)	1
13	1175	Screw for 22964	ワイヤ支工(後)止ネジ	1
14	22947	Flexible Wire Stay Bushing	ワイヤ支工ブッシュ	2
15	3638	Screw for 22947, 22981	止ネジ	3
16	4132	Screw for Top Cover	上カバー止ネジ	1
17	22972	Flexible Wire Unit	ワイヤ(組)	1
18	22963	Flexible Wire Stay (Front)	ワイヤ支工(前)	1
19	22981	Flexible Wire Stay (Front) Shaft	ワイヤ支工(前)取付軸	1
20	531	Washer for 22966	ワッシャ	2
21	22966	Flexible Wire Return Spring	ワイヤ戻シバネ	1
22	22962	Ruffling Presser & Fabric Presser Lifting Lever	ラフリング押工揚ゲレバー	1
23	4100	Screw for 22962	ラフリング押工揚ゲレバー止ネジ	1
24	22961	Ruffling Presser Lifting Lever Support	ラフリング押工揚ゲレバー取付台	1
25	7605	Screw for 22961	ラフリング押工揚ゲレバー取付台止ネジ	1
26	4353	Screw for 22961	ラフリング押工揚ゲレバー取付台止ネジ	1
27	20301	Intermediate Lever Spring	押工揚ゲ軸バネ	1

Z5056,5057(2)

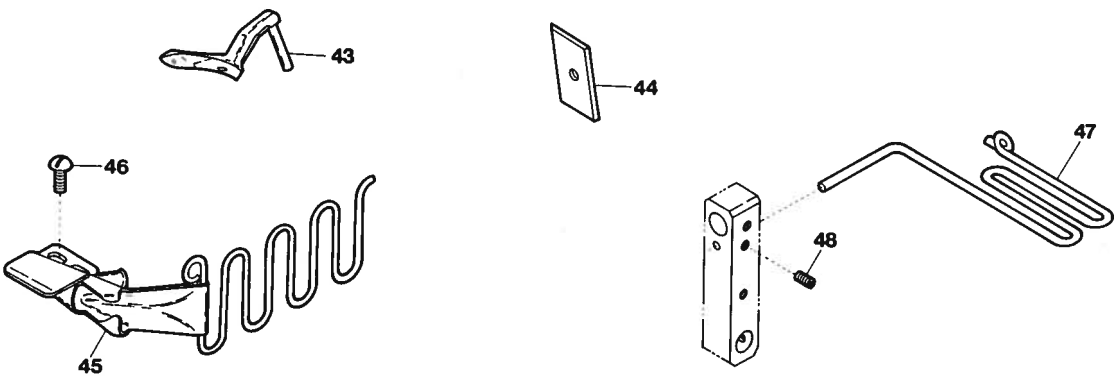
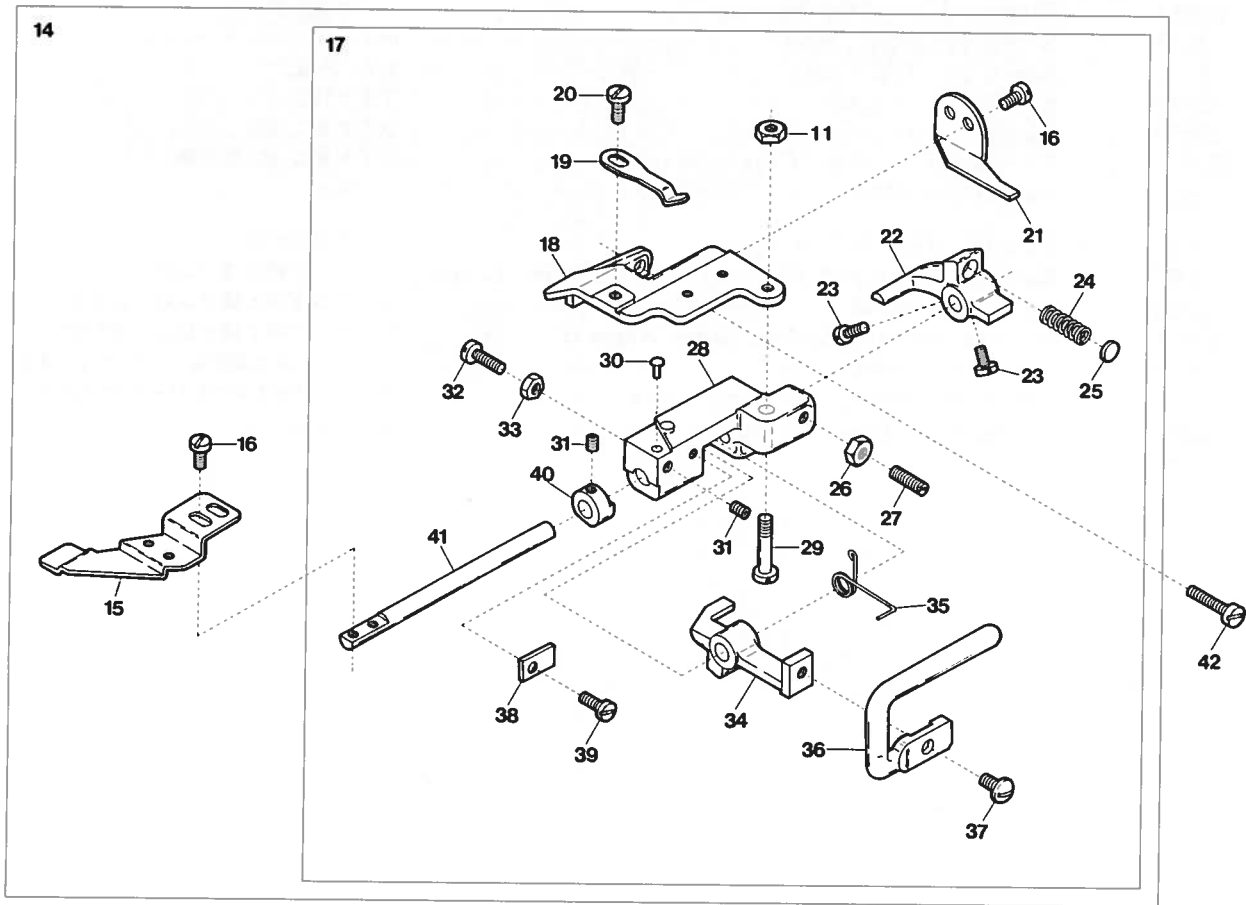
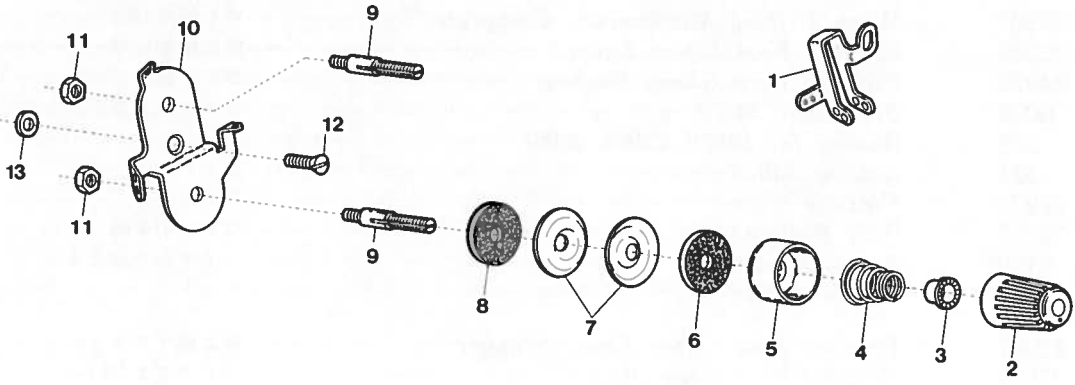

Ref. No.	Parts No.	Description	品名	Amt. Req.
1	23467	Needle Thread Eyelet	針糸道	1
2	20104	Thread Tension Spring Cap	糸調子バネキャップ(上)	1
3	33890	Tension Spring Bushing	糸調子ナット回り止め	1
4	30255	Tension Spring	糸調子バネ	1
5	20118	Thread Tension Spring Retainer	糸調子バネキャップ(下)	1
6	178	Felt for 31111	フェルト	1
7	31111	Tension Disc	糸調子皿	2
8	177	Felt for 31111	フェルト	1
9	4125	Tension Post	糸調子棒	2
10	22970	Tension Disc Eyelet for Needle Thread	調子台糸道(大)	1
11	340	Nut for 4125, 20630	ナット	3
12	5345	Screw for 22970	調子台糸道止ネジ	1
13	538	Spacer for 22970	スペーサ	1
14	24461	Ruffling Mechanism, Complete Set(2)	ラフリング装置(組2)	1
15	20612	Ruffling Presser	ラフリング押エ	1
16	5036	Screw for 20612, 20631	止ネジ	4
17	24460	Ruffling Mechanism, Complete Set(1)	ラフリング装置(組1)	1
18	20611	Shaft Bracket Holder	ブラケット取付台	1
19	33397	Bracket Spring Plate	ブラケット止めバネ	1
20	7006	Screw for 33397	ブラケット止めバネ止ネジ	1
21	20631	Shaft Bracket Support	ブラケット受け	1
22	24463	Shaft Lever	ラフリング押エ軸レバー	1
23	7302	Screw for 24463	ラフリング押エ軸レバー止ネジ	2
24	33398	Ruffling Presser Spring	ラフリング押エバネ	1
25	519	Washer for 33398	ワッシャ	1
26	355	Lock Nut for 3556	ロックナット	1
27	3556	Adjusting Screw for 33398	ラフリング押エバネ調節ネジ	1
28	20630	Shaft Bracket	ブラケット	1
29	6142	Screw for 20630	ブラケット止ネジ	1
30	632	Pin for 33397	ピン	1
31	3637	Screw for 632, 20616	止ネジ	2
32	7609	Positioning Screw for 20630	ブラケット位置決めネジ	1
33	335	Lock Nut for 7609	ロックナット	1
34	24462	Swing-out Handle Holder	押エ掲げハンドル取付台	1
35	24464	Swing-out Handle Holder Spring	ハンドル取付台バネ	1
36	24466	Swing-out Handle (for Ruffling Presser)	押エ掲げハンドル	1
37	4591	Screw for 24466	押エ掲げハンドル止ネジ	1
38	24465	Swing-out Handle Holder Stopper	ハンドル取付台ストッパ	1
39	5000	Screw for 24465	ハンドル取付台ストッパ止ネジ	1
40	20616	Stopper Collar	ストッパカラー	1
41	33394	Shaft (for Ruffling Presser & Piping Folder)	ラフリング押エ軸	1
42	5043	Screw for 20611	ブラケット取付台止ネジ	2
43	21754	Upper Looper	上ルーバ	1
44	24343	Lower Knife Clamp	下メス押エ	1
45	20686	Folder (A)(Tape Width 20mm)	定規(A)(テープ幅20mm)	1
46	1330	Screw for 20686	定規止ネジ	2
47	22982	Tape Guide	テープガイド	1
48	3638	Screw for 22982	テープガイド止ネジ	1

Z5056-X4,5057-X4

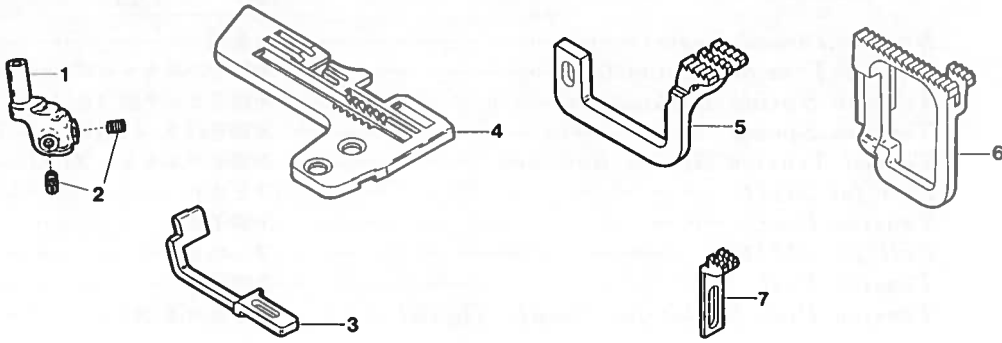

Z5056-X4

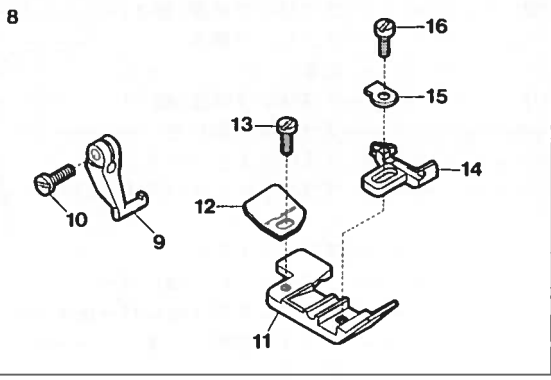

Z5057-X4

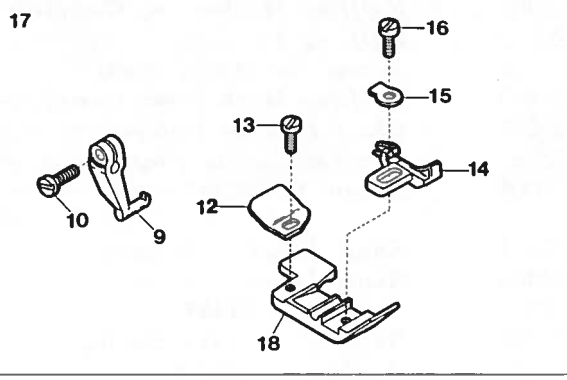

Z5056-Y5,5057-Y5

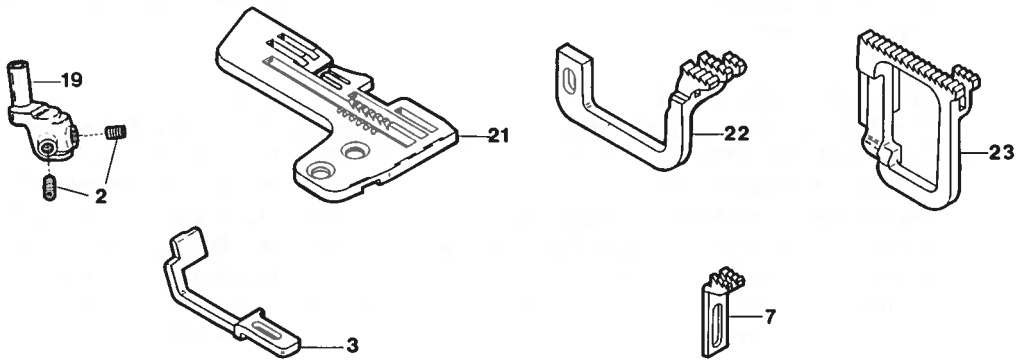

Z5056-Y5

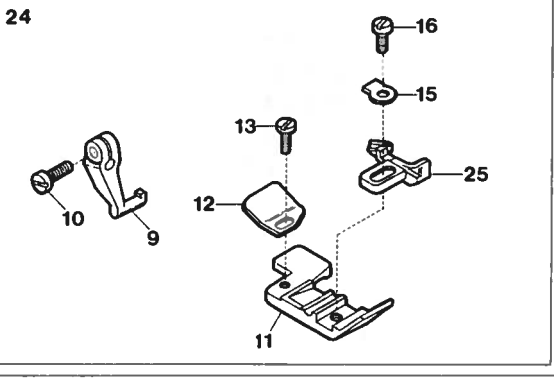

Z5057-Y5

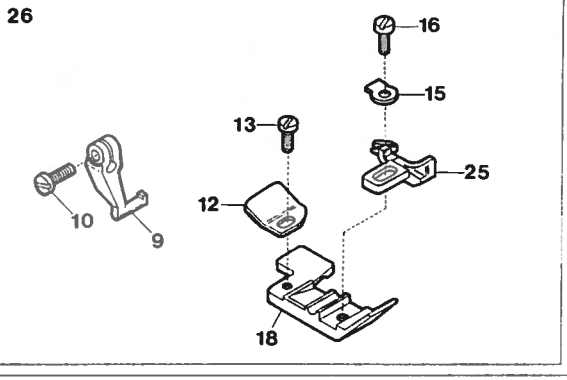

Ref. No.	Parts No.	Description	品名	Amt. Req.
1	21893	Needle Clamp (X)	針止メ(X)	1
2	3637	Screw for Needle	針止ネジ	2
3	20676	Needle Guard (Front)	針受ケ(前)	1
4	22952	Stitch Plate	針板	1
5	22983	Differential Feed Dog	前送り	1
6	22991	Main Feed Dog	後送り	1
7	22956	Auxiliary Feed Dog	小送り	1
8	23150	Presser Foot, Complete Set (Z5056-X4)	押工(組)	1
9	21938	Presser Foot Hinge	押工ヒンジ	1
10	4351	Screw for 21938	押工ヒンジ止ネジ	1
11	22985	Presser Foot (Lower)	押工(下)	1
12	34535	Presser Foot Chain Shield	空糸押工	1
13	1228	Screw for 34535	空糸押工止ネジ	1
14	22986	Presser Foot Stitch Tongue	爪	1
15	21005	Presser Foot Hinge Spring	押工ヒンジバネ	1
16	4131	Screw for 21005	押工ヒンジバネ止ネジ	1
17	23160	Presser Foot, Complete Set (Z5057-X4)	押工(組)	1
18	22990	Presser Foot (Lower)	押工(下)	1
19	21891	Needle Clamp (Y)	針止メ(Y)	1
20				
21	22954	Stitch Plate	針板	1
22	22984	Differential Feed Dog	前送り	1
23	22992	Main Feed Dog	後送り	1
24	23154	Presser Foot, Complete Set (Z5056-Y5)	押工(組)	1
25	22988	Presser Foot Stitch Tongue	爪	1
26	23164	Presser Foot, Complete Set (Z5057-Y5)	押工(組)	1

"C" DEVICE

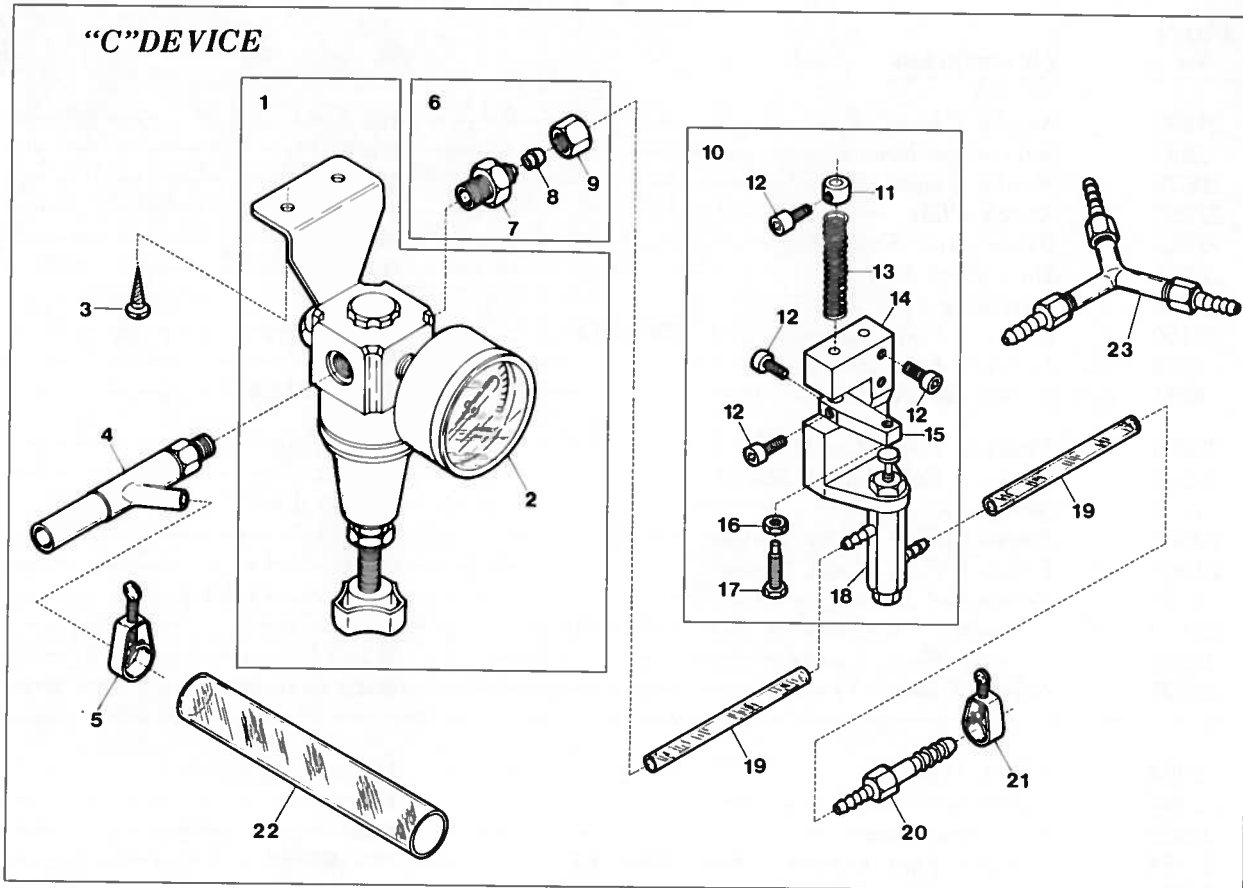

"K2", "KT2", "KR2" DEVICE

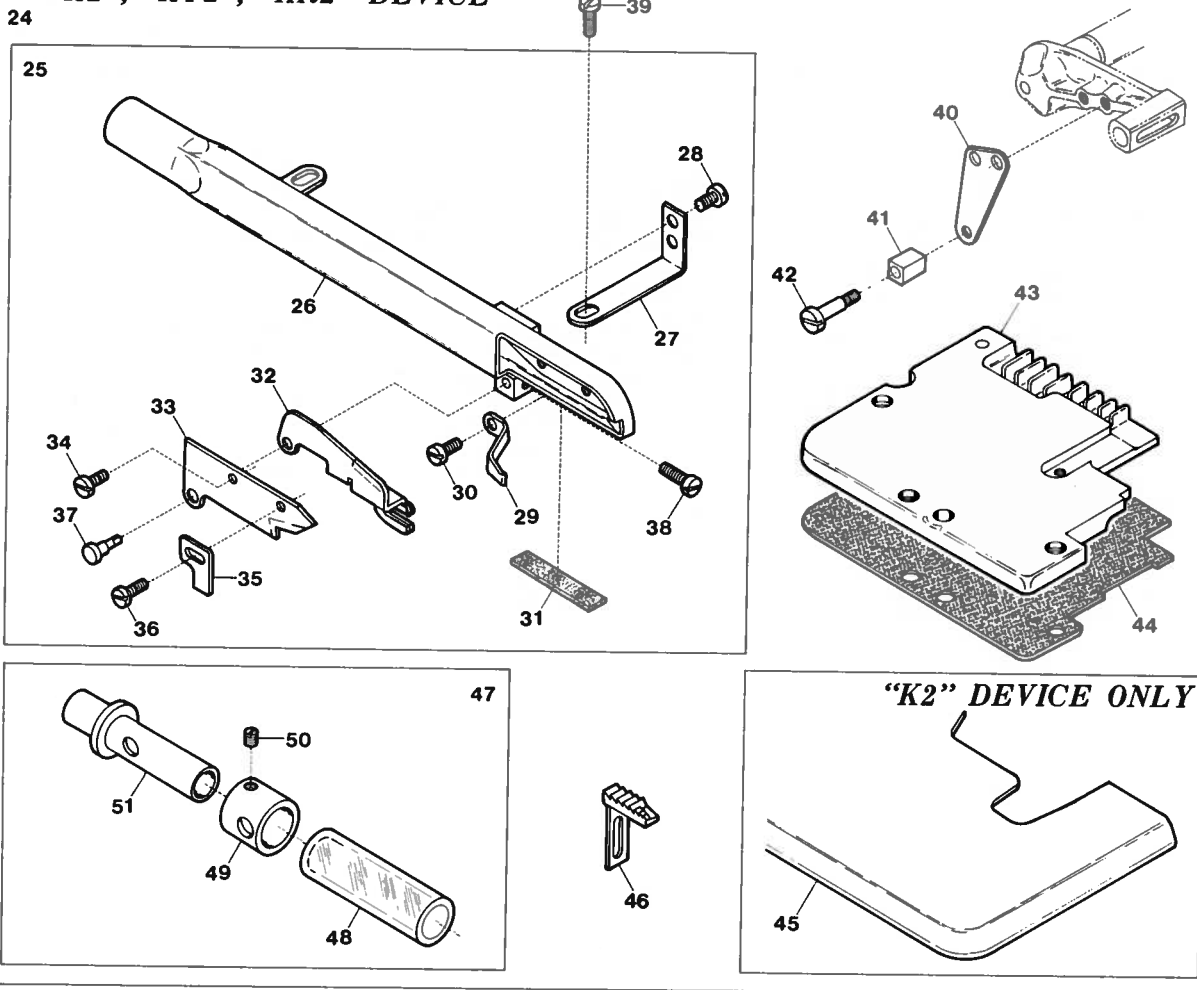

"K2" DEVICE ONLY

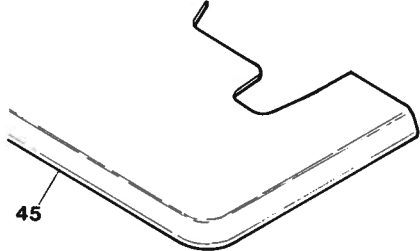

Ref. No.	Parts No.	Description	品 名	Amt. Req.
1	33925	Regulator, Complete Set	レギュレータ(組)	1
2	33928	Pressure Gauge	プレッシャーゲージ	1
3	6905	Screw for 33925	レギュレータ(組)止ネジ	2
4	10100	Venturi Tube, Complete Set	ベンチュリー管(組)	1
5	33940	Hose Band (3/8 inch)	ホースバンド 3/8インチ	1
6	33931	Mouth-Piece, Complete Set (PT 1/8 inch)	ストレートジョイント(組) 1/8インチ	1
7	33949	Mouth-Piece (PT 1/8 inch)	ストレートジョイント 1/8インチ	1
8	33951	Pipe Holder	ナイロンホルダ	1
9	33950	Nut for Straight Joint	ナット	1
10	33953	Air Valve, Complete Set	エアバルブ(組)	1
11	33938	Collar for 33937	エアバルブ補助バネカラー	1
12	5040	Screw for 33938, 33936, 33935	止ネジ	5
13	33937	Return Spring for Air Valve Stopper	エアバルブ補助バネ	1
14	33936	Holder for Air Valve	エアバルブ取付台	1
15	33935	Air Valve Stopper	エアバルブストッパ	1
16	334	Nut for 33935	ナット	1
17	5505	Screw for 33935	エアバルブストッパ調節ネジ	1
18	33934	Air Valve	エアバルブ	1
19	33941	Nylon Hose (3.8×6×2000mm)	ナイロンホース	2
20	33932	Joint, for Single Head	ジョイント(ミシガ1台の時のみ使用)	1
21	33939	Hose Band (1/4 inch)	ホースバンド 1/4インチ	3
22	33942	Nylon Hose (12×18×1000mm)	ナイロンホース12φ	1
23	33933	Three Pronged Joint, for Plural Heads	三又ジョイント(ミシガ2台以上の時使用)	1
24	21699	"K2" Device, Complete Set ("K2" Device only)	"K2"装置(組)("K2"装置のみ)	1
25	21674	Suction Pipe, Complete Set	吸込管(組)	1
26	21673	Suction Pipe	吸込管	1
27	21058	Suction Pipe Stay (Front)	吸込管支工(前)	1
28	9730	Screw for 21058	吸込管支工(前)止ネジ	2
29	21667	Lower Trimming Knife Pushing Plate	下刃圧着バネ	1
30	4237	Screw for 21667	下刃圧着バネ止ネジ	1
31	21675	Air Defence Rubber	空気漏れ防止ゴム	1
32	21680	Lower Trimming Knife	下刃	1
33	21677	Upper Trimming Knife	上刃	1
34	1230	Screw for 21677	上刃止ネジ	1
35	21668	Upper Trimming Knife Guide	上刃ガイド	1
36	4404	Screw for 21668	上刃ガイド止ネジ	1
37	33588	Trimming Knife Holder Pin	刃支持ピン	1
38	1222	Screw for 33588	刃支持ピン止ネジ	1
39	4358	Screw for 21058	吸込管支工(前)止ネジ	1
40	21682	Lower Trimming Knife Connecting Sleeve Support	下刃ガイド取付板	1
41	21683	Lower Trimming Knife Connecting Sleeve	下刃ガイド	1
42	4148	Screw for 21683	下刃ガイド止ネジ	1
43	21746	Feed Mechanism Cover	送り台カバー	1
44	21739	Feed Mechanism Cover Gasket	送り台カバーパッキン	1
45	21928	Cloth Plate ("K2" Device only)	クロスプレート("K2"装置のみ)	1
46	21685	Auxiliary Feed Dog	小送り	1
47	21451	Suction Power Control Tube, Complete Set	吸引力調整管(組)	1
48	21450	Nylon Hose	ナイロンホース	1
49	21456	Suction Power Control Tube	吸引力調整管	1
50	1892	Screw for 21456	吸引力調整管止ネジ	1
51	21457	Suction Power Control Tube (Inner)	吸引力調整台	1

(注) Ref. No. 45 21928のクロスプレートはK2装置のみのものですから、KT2, KR2装置については35ページを参照して下さい。

Note: Cloth Plate, No.21928, Ref. No.45 is only for "K2" Device, so those for "KT2" and "KR2" Devices must be referred to the list on Page 35.

"K2", "KT2", "KR2" DEVICE(2)

Z5000

1-1
1-2
1-3

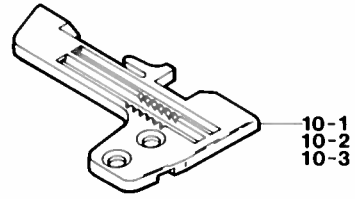
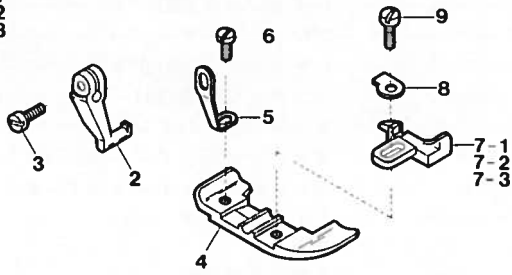

Z5000/CH20

11-1
11-2
11-3

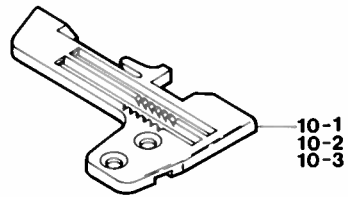
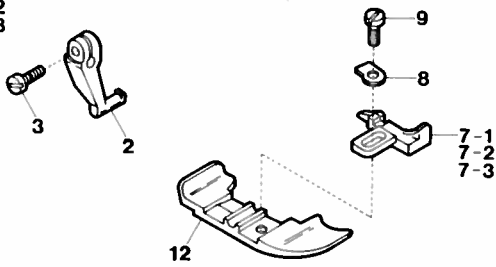

Z5003

13-1
13-2
13-3
13-4

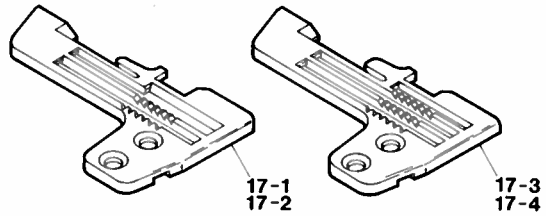
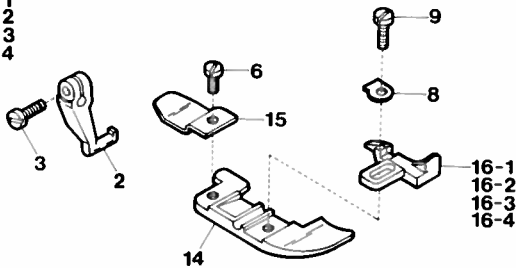

Z5003-3

18

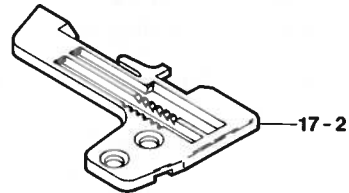
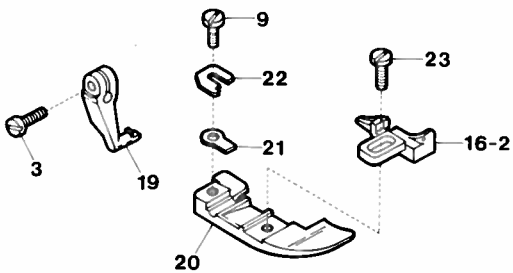

Z5037

24

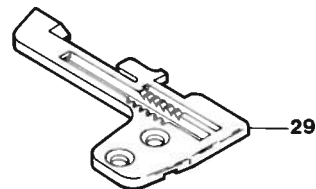
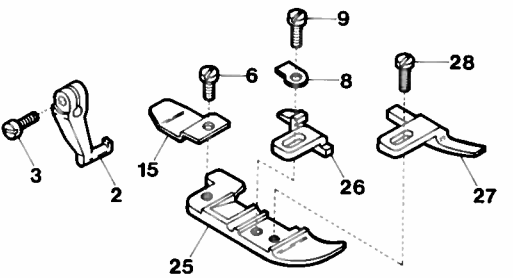

Ref. No.	Parts No.	Description	品名	Amt. Req.
1-1	21947	Presser Foot, Complete Set (03)	押工(組) (03)	1
1-2	21948	" " (04)	" (04)	1
1-3	21949	" " (05)	" (05)	1
2	21938	Presser Foot Hinge	押工ヒンジ	1
3	4351	Screw for 21938, 21242	押工ヒンジ止ネジ	1
4	21946	Presser Foot (Lower)	押工(下)	1
5	21301	Presser Foot Stay	押工固定片	1
6	1228	Screw for 21301, 33471	止ネジ	1
7-1	21880	Presser Foot Stitch Tongue (03)	爪(03)	1
7-2	21881	" " (04)	" (04)	1
7-3	21882	" " (05)	" (05)	1
8	21005	Presser Foot Hinge Spring	押工ヒンジバネ	1
9	4131	Screw for 21005, 22519	止ネジ	1
10-1	21686	Stitch Plate (03)	針板(03)	1
10-2	21687	" (04)	" (04)	1
10-3	21688	" (05)	" (05)	1
11-1	21961	Presser Foot, Complete Set (03)	押工(組) (03)	1
11-2	21962	" " (04)	" (04)	1
11-3	21963	" " (05)	" (05)	1
12	21960	Presser Foot (Lower)	押工(下)	1
13-1	23008	Presser Foot, Complete Set (03)	押工(組) (03)	1
13-2	23010	" " (04)	" (04)	1
13-3	23012	" " (05)	" (05)	1
13-4	23014	" " (06)	" (06)	1
14	21972	Presser Foot (Lower)	押工(下)	1
15	33471	Presser Foot Chain Shield	空糸押工	1
16-1	21871	Presser Foot Stitch Tongue (03)	爪(03)	1
16-2	21872	" " (04)	" (04)	1
16-3	21873	" " (05)	" (05)	1
16-4	21874	" " (06)	" (06)	1
17-1	21690	Stitch Plate (03)	針板(03)	1
17-2	21691	" (04)	" (04)	1
17-3	21692	" (05)	" (05)	1
17-4	21693	" (06)	" (06)	1
18	22529	Presser Foot, Complete Set (04)	押工(組) (04)	1
19	21242	Presser Foot Hinge	押工ヒンジ	1
20	22535	Presser Foot (Lower)	押工(下)	1
21	21243	Presser Foot Hinge Spring	押工ヒンジバネ	1
22	22519	Presser Foot Adjusting Plate	押工調節板	1
23	4138	Screw for 21872	爪止ネジ	1
24	22820	Presser Foot, Complete Set (05)	押工(組) (05)	1
25	22819	Presser Foot (Lower)	押工(下)	1
26	22816	Presser Foot Stitch Tongue (05)	爪(05)	1
27	22815	Fabric Guard	布押工	1
28	4236	Screw for 22815	布押工止ネジ	1
29	22823	Stitch Plate (05)	針板(05)	1

"K2", "KT2", "KR2" DEVICE(3)

Z5020-X ,5020-X-4

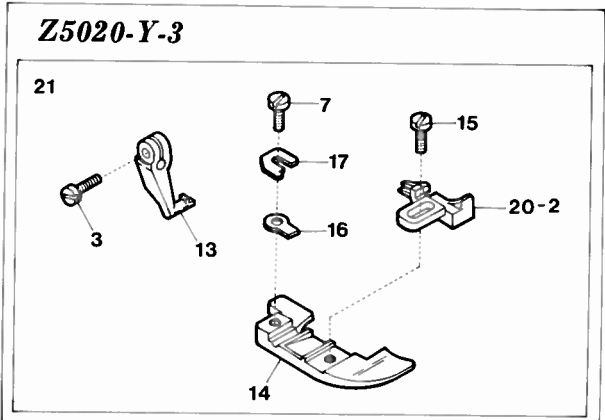
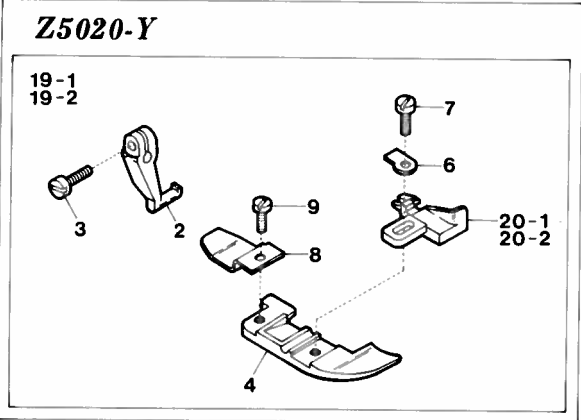
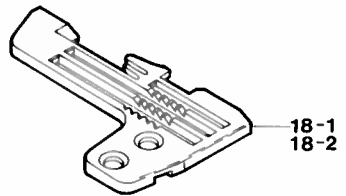
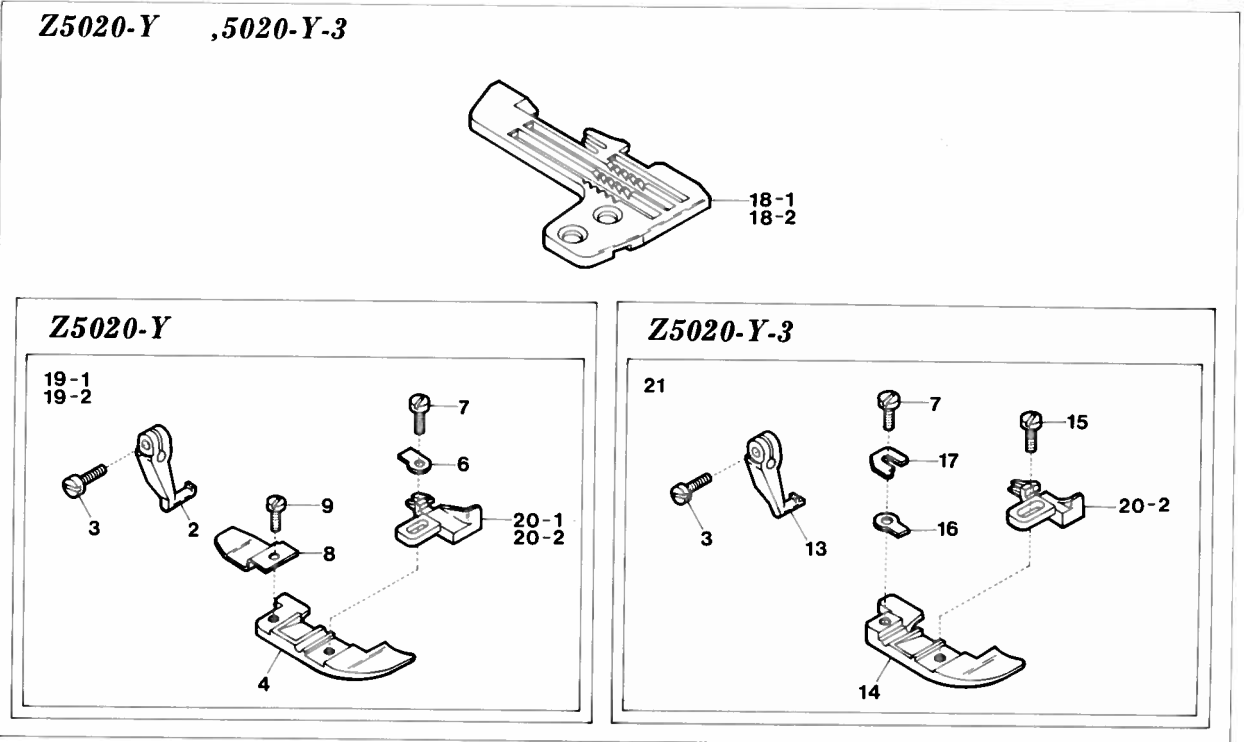
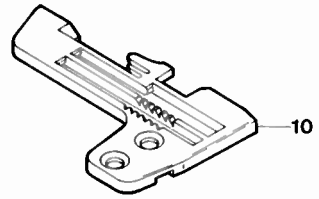
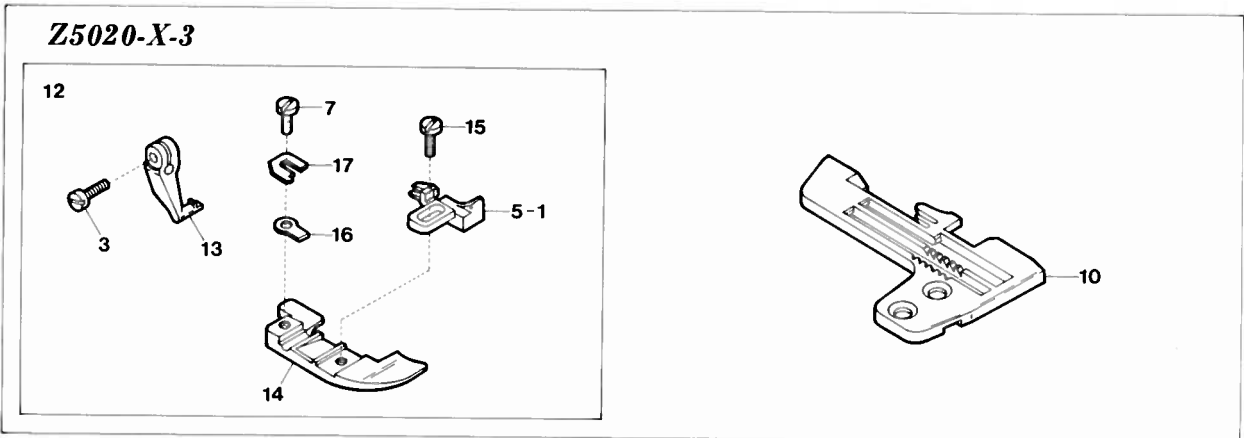
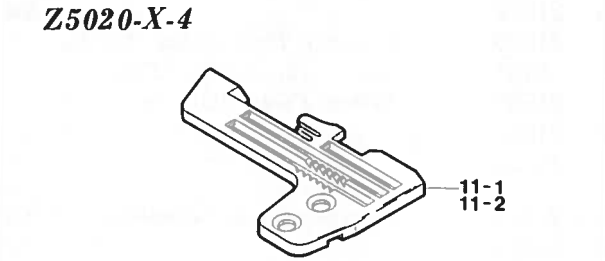
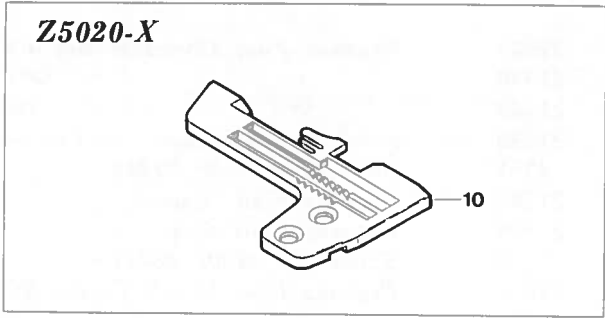
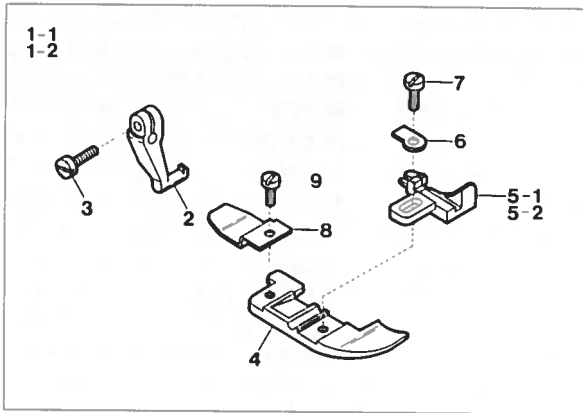

Ref. No.	Parts No.	Description	品名	Amt. Req.
1-1	23038	Presser Foot, Complete Set (X4).....	押エ(組)(X4).....	1
1-2	23040	" " (X5).....	" (X5).....	1
2	21938	Presser Foot Hinge.....	押エヒンジ.....	1
3	4351	Screw for 21938, 21242.....	押エヒンジ止ネジ.....	1
4	21972	Presser Foot (Lower).....	押エ(下).....	1
5-1	21870	Presser Foot Stitch Tongue (X4).....	爪(X4).....	1
5-2	22600	" " (X5).....	" (X5).....	1
6	21005	Presser Foot Hinge Spring.....	押エヒンジバネ.....	1
7	4131	Screw for 21005, 22519.....	止ネジ.....	1
8	33471	Presser Foot Chain Shield.....	空糸押エ.....	1
9	1228	Screw for 33471.....	空糸押エ止ネジ.....	1
10	21694	Stitch Plate (X4).....	針板(X4).....	1
11-1	22611	Stitch Plate (X4-4).....	針板(X4-4).....	1
11-2	22602	" (X5-4).....	" (X5-4).....	1
12	22533	Presser Foot, Complete Set (X4-3).....	押エ(組)(X4-3).....	1
13	21242	Presser Foot Hinge.....	押エヒンジ.....	1
14	22535	Presser Foot (Lower).....	押エ(下).....	1
15	4138	Screw for 21870, 21865.....	爪止ネジ.....	1
16	21243	Presser Foot Hinge Spring.....	押エヒンジバネ.....	1
17	22519	Presser Foot Adjusting Plate.....	押エ調節板.....	1
18-1	21695	Stitch Plate (Y5).....	針板(Y5).....	1
18-2	21696	" (Y6).....	" (Y6).....	1
19-1	23042	Presser Foot, Complete Set (Y5).....	押エ(組)(Y5).....	1
19-2	23044	" " (Y6).....	" (Y6).....	1
20-1	21864	Presser Foot Stitch Tongue (Y5).....	爪(Y5).....	1
20-2	21865	" " (Y6).....	" (Y6).....	1
21	22531	Presser Foot, Complete Set (Y6-3).....	押エ(組)(Y6-3).....	1

"KT2", "KR2" DEVICE(4)

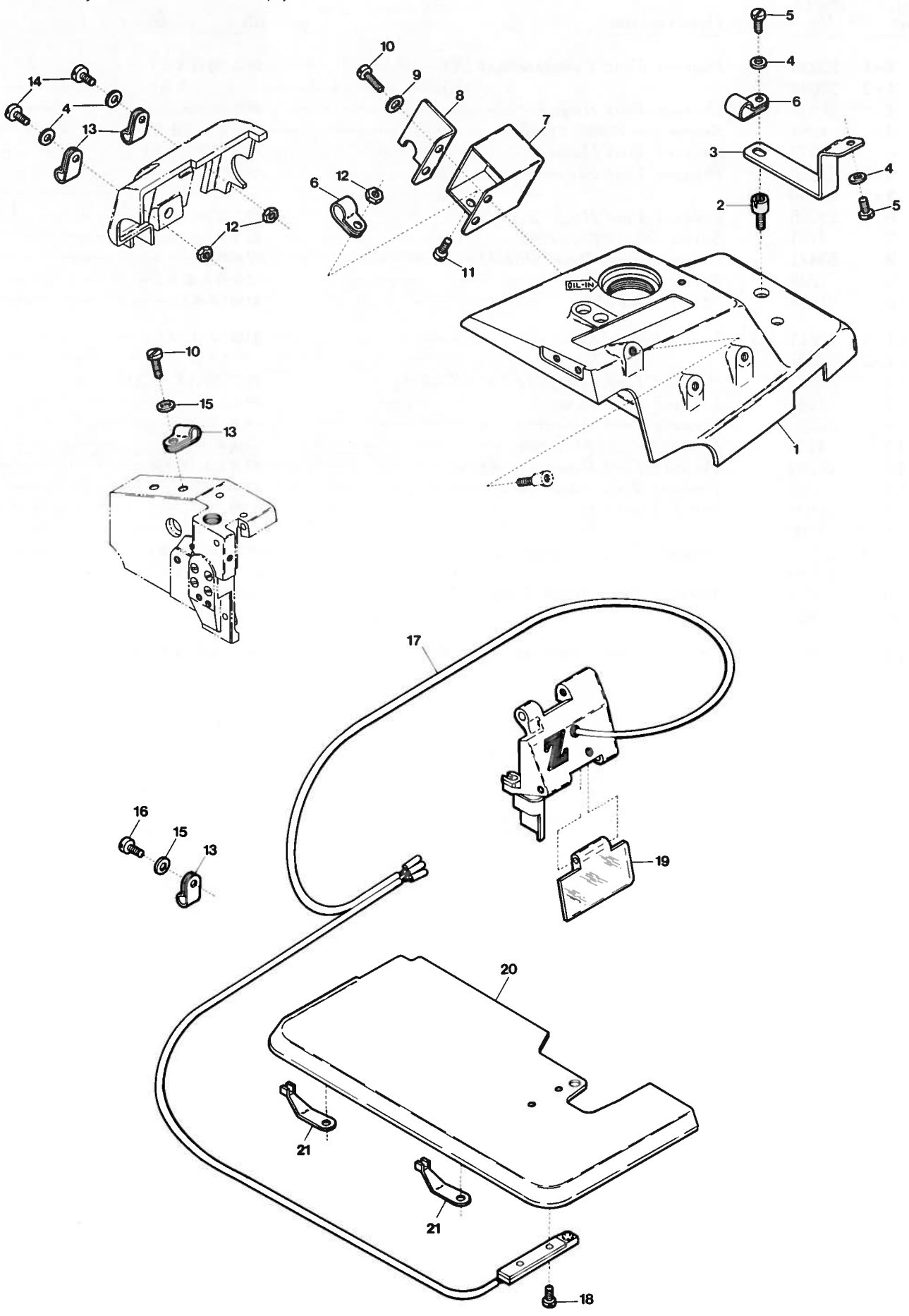

Ref. No.	Parts No.	Description	品名	Amt. Req.
1	24303	Top Cover	上カバー	1
2	4132	Screw for 24303	上カバー止ネジ	1
3	23191	Solenoid Stay (“KR2” Device only)	ソレノイドステイ (“KR2”装置のみ)	1
4	532	Washer for 23191, 94491	ワッシャ	4
5	4358	Screw for 23191	ソレノイドステイ止ネジ	2
6	36133	Cord Clamp (φ 8.4)	コードクランプ	2
7	11840	Connector Case	コネクタケース	1
8	11841	Connector Case Lid	コネクタケース蓋	1
9	550	Washer for 11841	ワッシャ	2
10	4440	Screw for 11841, 94491	止ネジ	3
11	4352	Screw for 36133	コードクランプ止ネジ	1
12	335	Nut for 36133, 94491	ナット	3
13	94491	Cord Clamp (φ 3.4)	コードクランプ	4
14	1175	Screw for 94491	コードクランプ止ネジ	2
15	542	Washer for 94491	ワッシャ	2
16	9853	Screw for 94491	コードクランプ止ネジ	1
17	11888	Photoelectric Switch, Complete Set	光電スイッチ(組)	1
18	4404	Screw for 11888	光電スイッチ(組)止ネジ	2
19	23175	Safety Plate	アイガード	1
20	22632	Cloth Plate	クロスプレート	1
21	24301	Cord Stay (Small)	コード支エ	2

"KT2", "KR2" DEVICE(5)

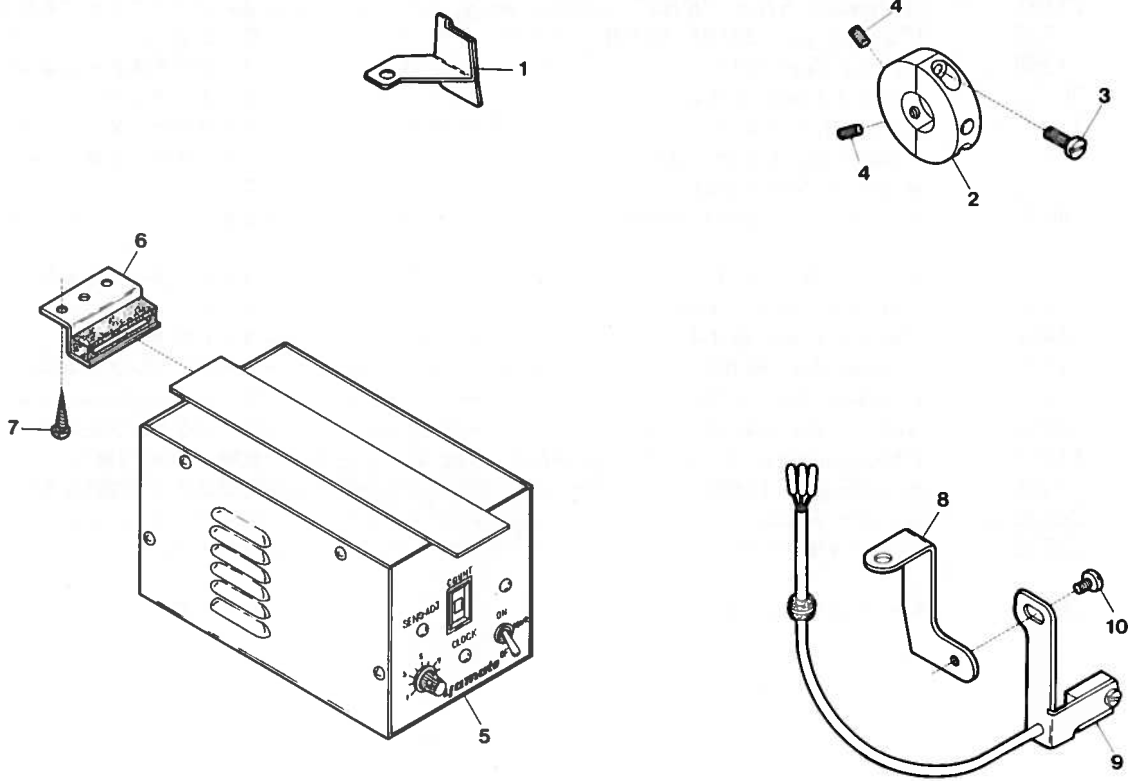

<u>Ref.</u> <u>No.</u>	<u>Parts</u> <u>No.</u>	<u>Description</u>	<u>品 名</u>	<u>Amt.</u> <u>Req.</u>
1	22635	Lower Looper Cover	下ルーバカバー.....	1
2	23179	Magnet Holding Ring Unit	マグネット(組).....	1
3	7609	Screw for 23179	マグネット(組)止ネジ.....	2
4	9209	Screw for 23179	マグネット(組)止ネジ.....	1
5	11323	Control Box, Complete Set	制御装置(組).....	1
6	11709	Control Box Stay	コントロールボックスステイ.....	2
7	6910	Screw for 11709	コントロールボックスステイ止ネジ.....	4
8	21539	IC Unit Supporting Plate.....	IC装置取付板支エ.....	1
9	11880	IC Unit (DN834)	ホールIC(組).....	1
10	5506	Screw for 11880	ホールIC(組)止ネジ.....	1

"KR2" DEVICE(6)

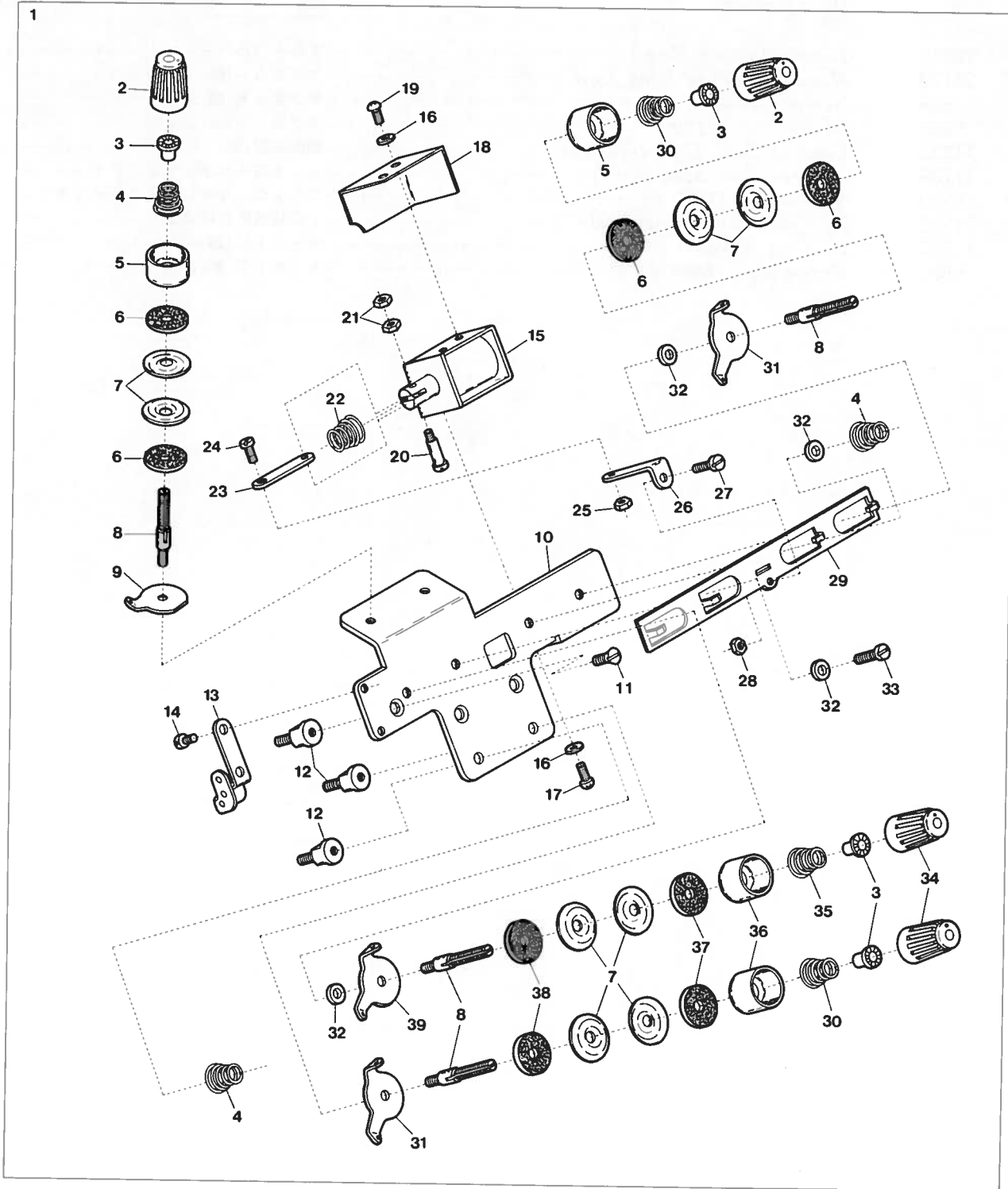

Ref. No.	Parts No.	Description	品名	Amt. Req.
1	23198	Thread Tension Release, Complete Set	糸緩メ装置(組)	1
2	33806	Thread Tension Spring Cap	糸調子バネキャップ(上)	3
3	33890	Thread Tension Spring Bushing	糸調子ナット回り止メ	6
4	20103	Thread Tension Spring	糸調子バネ	3
5	33807	Thread Tension Spring Retainer	糸調子バネキャップ(下)	3
6	286	Felt for 31111	フェルト	6
7	31111	Tension Disc	糸調子皿	12
8	7904	Tension Post	糸調子棒	6
9	36853	Tension Disc Eyelet	調子台糸道	1
10	23185	Thread Tension Release Supporting Board	糸緩メ台	1
11	1396	Screw for 23185	糸緩メ台止ネジ	1
12	4151	Screw for 23185	糸緩メ台取付ケネジ	3
13	23188	Tension Disc Auxiliary Eyelet	調子台補助糸道	1
14	4358	Screw for 23188, 23191	止ネジ	3
15	11839	Thread Tension Release Solenoid	ソレノイド	1
16	14	Washer for 11839, 23189	ワッシャ	4
17	9994	Screw for 11839	ソレノイド止ネジ	2
18	23189	Solenoid Cover	ソレノイドカバー	1
19	9995	Screw for 23189	ソレノイドカバー止ネジ	2
20	5128	Solenoid Connecting Pin	ソレノイド連結ピン	1
21	21	Nut for 5128	ナット	2
22	32971	Solenoid Spring	ソレノイドバネ	1
23	23187	Thread Tension Release Link	糸緩メリンク	1
24	6092	Screw for 23187	糸緩メリンク止ネジ	1
25	330	Nut for 23187	ナット	1
26	23186	Thread Tension Release Plate Guide	糸緩メ板ガイド	1
27	4312	Screw for 23186	糸緩メガイド止ネジ	1
28	331	Nut for 23186	ナット	1
29	23190	Thread Tension Release Plate	糸緩メ板	1
30	20102	Thread Tension Spring	糸調子バネ	2
31	20101	Tension Disc Eyelet	調子台糸道	4
32	496	Spacer for 20101, 21001	スペーサ	4
33	9843	Screw for 496	スペーサ止ネジ	1
34	20104	Thread Tension Spring Cap	糸調子バネキャップ(上)	3
35	20132	Thread Tension Spring	糸調子バネ	1
36	20118	Thread Tension Spring Retainer	糸調子バネキャップ(下)	3
37	178	Felt for 31111	フェルト	3
38	177	Felt for 31111	フェルト	3
39	21001	Tension Disc Eyelet	調子台糸道	1

"KR2" DEVICE(7)

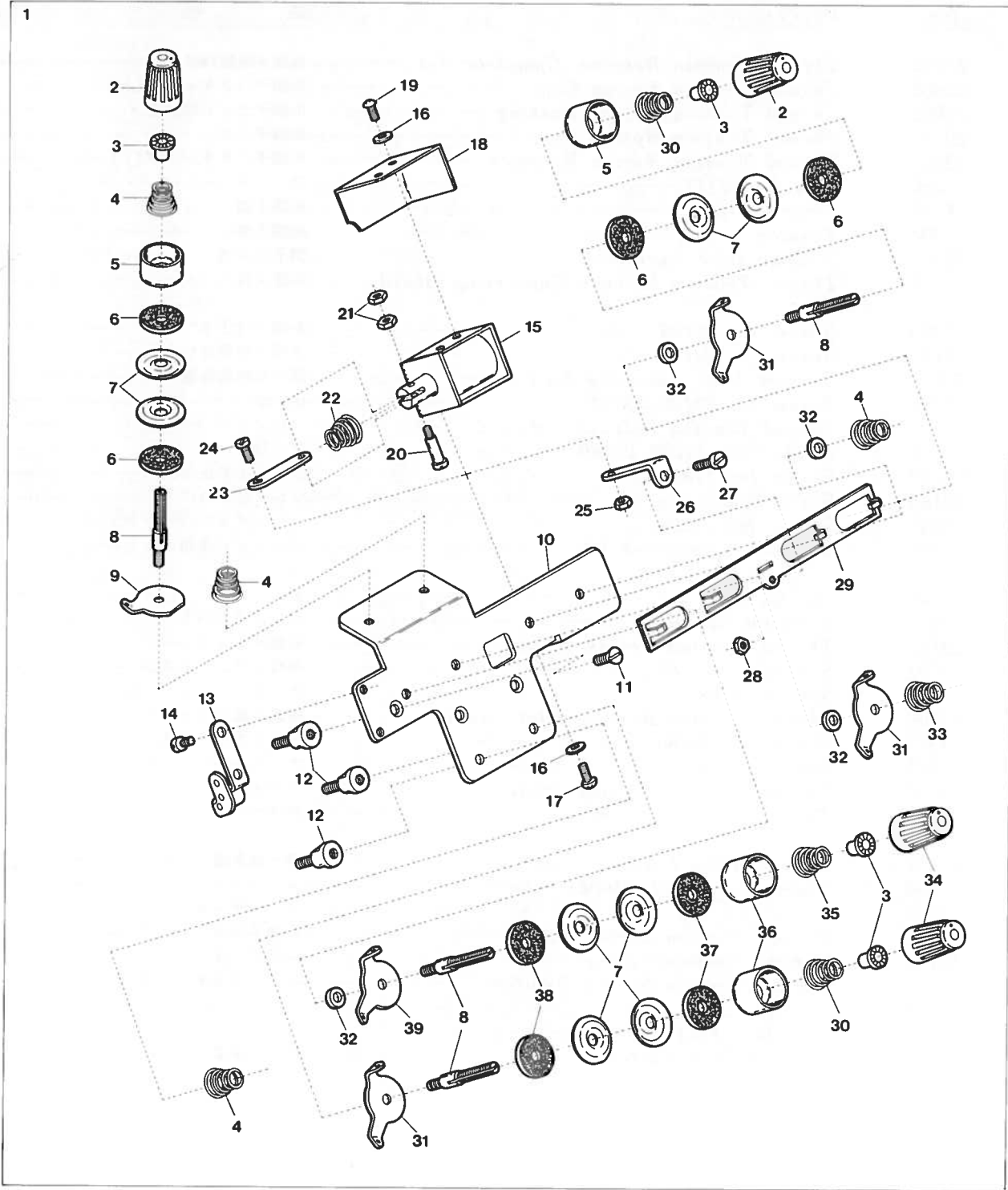

Ref. No.	Parts No.	Description	品名	Amt. Req.
1	23192	Thread Tension Release, Complete Set	糸緩メ装置(組)	1
2	33806	Thread Tension Spring Cap	糸調子バネキャップ(上)	4
3	33890	Thread Tension Spring Bushing	糸調子ナット回り止メ	8
4	20103	Thread Tension Spring	糸調子バネ	4
5	33807	Thread Tension Spring Retainer	糸調子バネキャップ(下)	4
6	286	Felt for 31111	フェルト	8
7	31111	Tension Disc	糸調子皿	16
8	7904	Tension Post	糸調子棒	8
9	36853	Tension Disc Eyelet	調子台糸道	2
10	23185	Thread Tension Release Supporting Board	糸緩メ台	1
11	1396	Screw for 23185	糸緩メ台止ネジ	1
12	4151	Screw for 23185	糸緩メ台取付ケネジ	3
13	23188	Tension Disc Auxiliary Eyelet	調子台補助糸道	1
14	4358	Screw for 23188, 23191	止ネジ	3
15	11839	Thread Tension Release Solenoid	ソレノイド	1
16	14	Washer for 11839, 23189	ワッシャ	4
17	9994	Screw for 11839	ソレノイド止ネジ	2
18	23189	Solenoid Cover	ソレノイドカバー	1
19	9995	Screw for 23189	ソレノイドカバー止ネジ	2
20	5128	Solenoid Connecting Pin	ソレノイド連結ピン	1
21	21	Nut for 5128	ナット	2
22	32971	Solenoid Spring	ソレノイドバネ	1
23	23187	Thread Tension Release Link	糸緩メリンク	1
24	6092	Screw for 23187	糸緩メリンク止ネジ	1
25	330	Nut for 23187	ナット	1
26	23186	Thread Tension Release Plate Guide	糸緩メ板ガイド	1
27	4312	Screw for 23186	糸緩メ板ガイド止ネジ	1
28	331	Nut for 23186	ナット	1
29	23190	Thread Tension Release Plate	糸緩メ板	1
30	20102	Thread Tension Spring	糸調子バネ	2
31	20101	Tension Disc Eyelet	調子台糸道	5
32	496	Spacer for 20101, 21001	スペーサ	4
33	20132	Thread Tension Spring	糸調子バネ	1
34	20104	Thread Tension Spring Cap	糸調子バネキャップ(上)	4
35	30255	Thread Tension Spring	糸調子バネ	1
36	20118	Thread Tension Spring Retainer	糸調子バネキャップ(下)	4
37	178	Felt for 31111	フェルト	4
38	177	Felt for 31111	フェルト	4
39	21001	Tension Disc Eyelet	調子台糸道	1

"MT2" DEVICE (1)

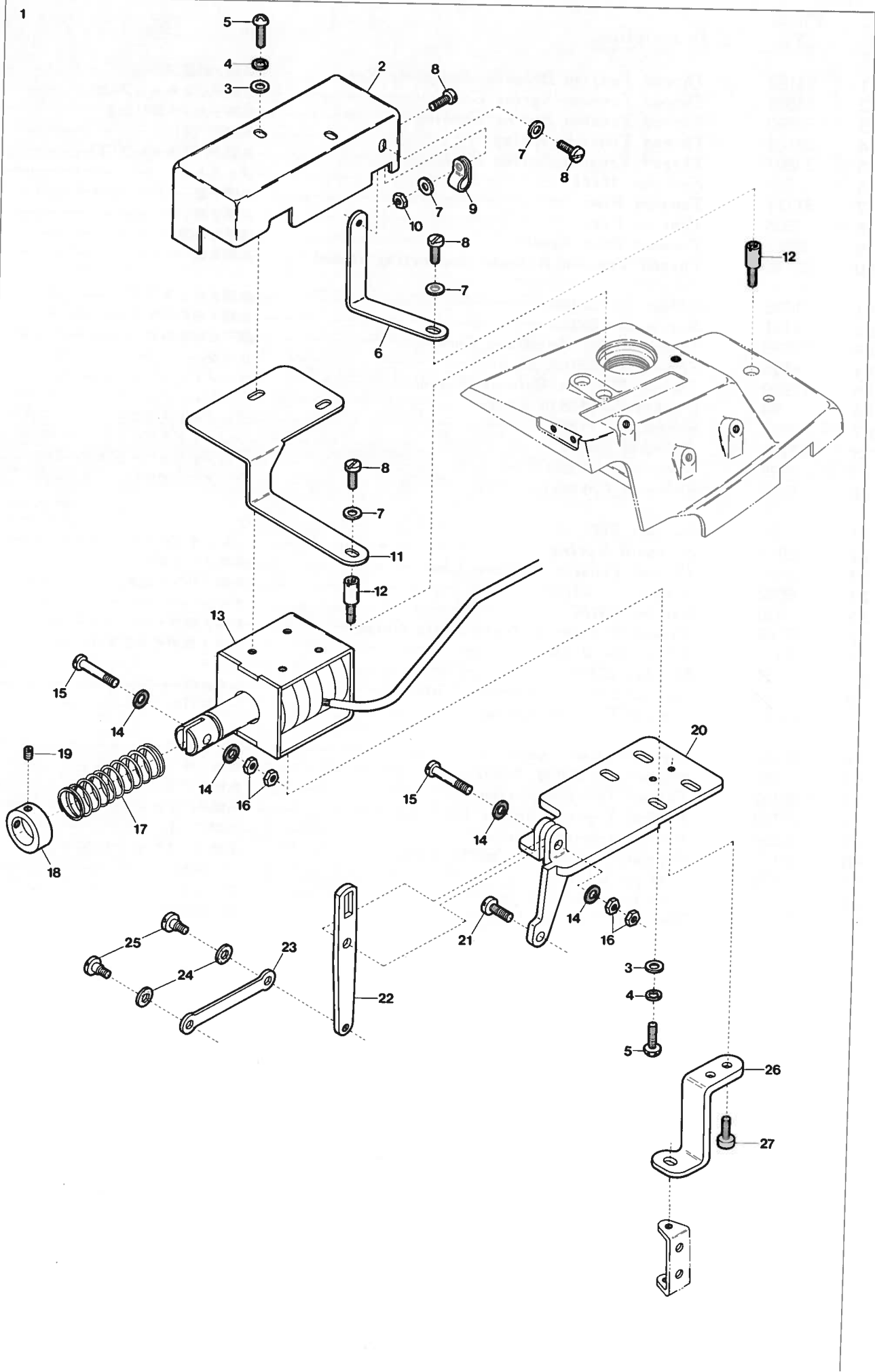

Ref. No.	Parts No.	Description	品 名	Amt. Req.
1-1	23390	“MT2” Device, Complete Set	“MT2”装置(組)	1
1-2	22638	“MT12” “ ” “ ”	“MT12” “ ” “ ”	1
2	22653	Solenoid Cover	ソレノイドカバー	1
3	538	Washer for 22653, 11760	ワッシャ	6
4	644	Spring Washer for 22653, 11760	スプリングワッシャ	6
5	9992	Screw for 22653, 11760	止ネジ	6
6	22687	Anti-vibration Plate for Solenoid Cover	ソレノイド振れ止メ板	1
7	532	Washer for 22687, 23381, 22652	ワッシャ	4
8	4353	Screw for 22687, 23381, 22652	止ネジ	4
9	23381	Cord Clamp (φ10.6)	コードクランプ	1
10	322	Nut for 23381	ナット	1
11	22652	Solenoid Supporting Plate	ソレノイド支工板	1
12	4132	Screw for Top Cover	上カバー止ネジ	2
13	11760	Solenoid	ソレノイド	1
14	187	Fiber Cushion	防振ファイバー	4
15	5127	Screw for Solenoid	ソレノイド連結ネジ	2
16	340	Nut for 5127	ナット	4
17	23447	Solenoid Spring	ソレノイドバネ	1
18	26312	Solenoid Spring Stopper Collar	ソレノイドバネ止メカラー	1
19	3312	Screw for 26312	ソレノイドバネ止メカラー止ネジ	2
20	23375	Solenoid Support	ソレノイド取付板	1
21	4635	Screw for 23375	ソレノイド取付板止ネジ	1
22	35298	Solenoid Connecting Lever	ソレノイドレバー	1
23	21484	Upper Knife Connecting Plate	上メス連結板	1
24	568	Rubber Cushion	防振ゴム	2
25	6068	Screw for 21484	上メス連結板止ネジ	2
26	20988	Solenoid Support Stay	ソレノイド取付板支工	1
27	5038	Screw for 20988	ソレノイド取付板支工止ネジ	2

※ Ref. No. 28 to 67 See the following page.

NOTE: Ref. No. 1 — Parts No. 23390 and 22638 for MT2 and MT12 Devices, Complete Set respectively is composed of all parts Ref. No. 2 to 27 on this page and No. 28 to 67 on next page.

(注) Ref. No. 2 (Parts No. 23390及び22638) MT2及びMT12装置(組)は、Ref. No. 2~27及び次ページのRef. No. 28~67までが含まれます。

"MT2" DEVICE(2)

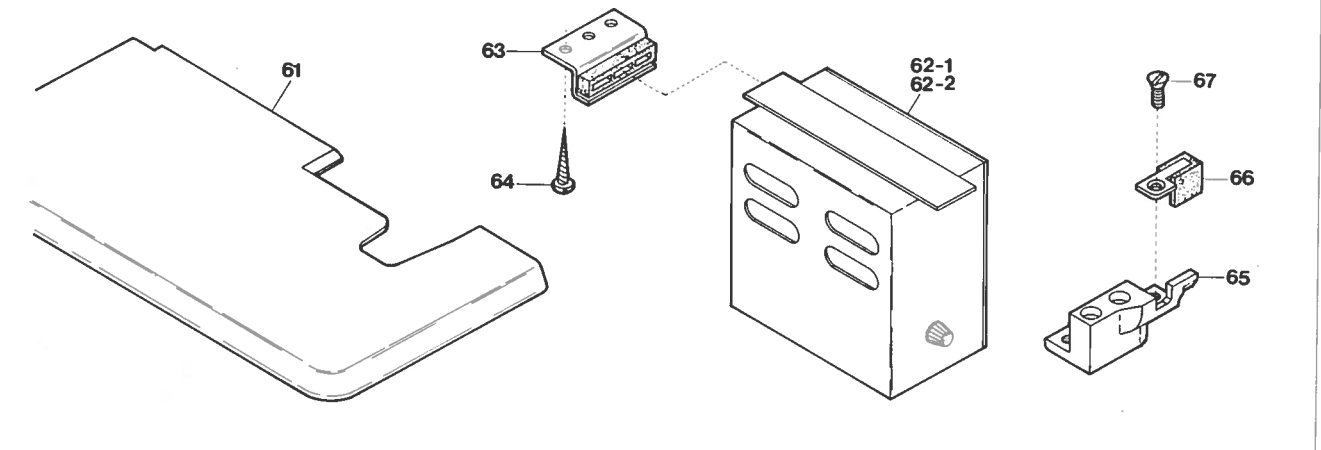
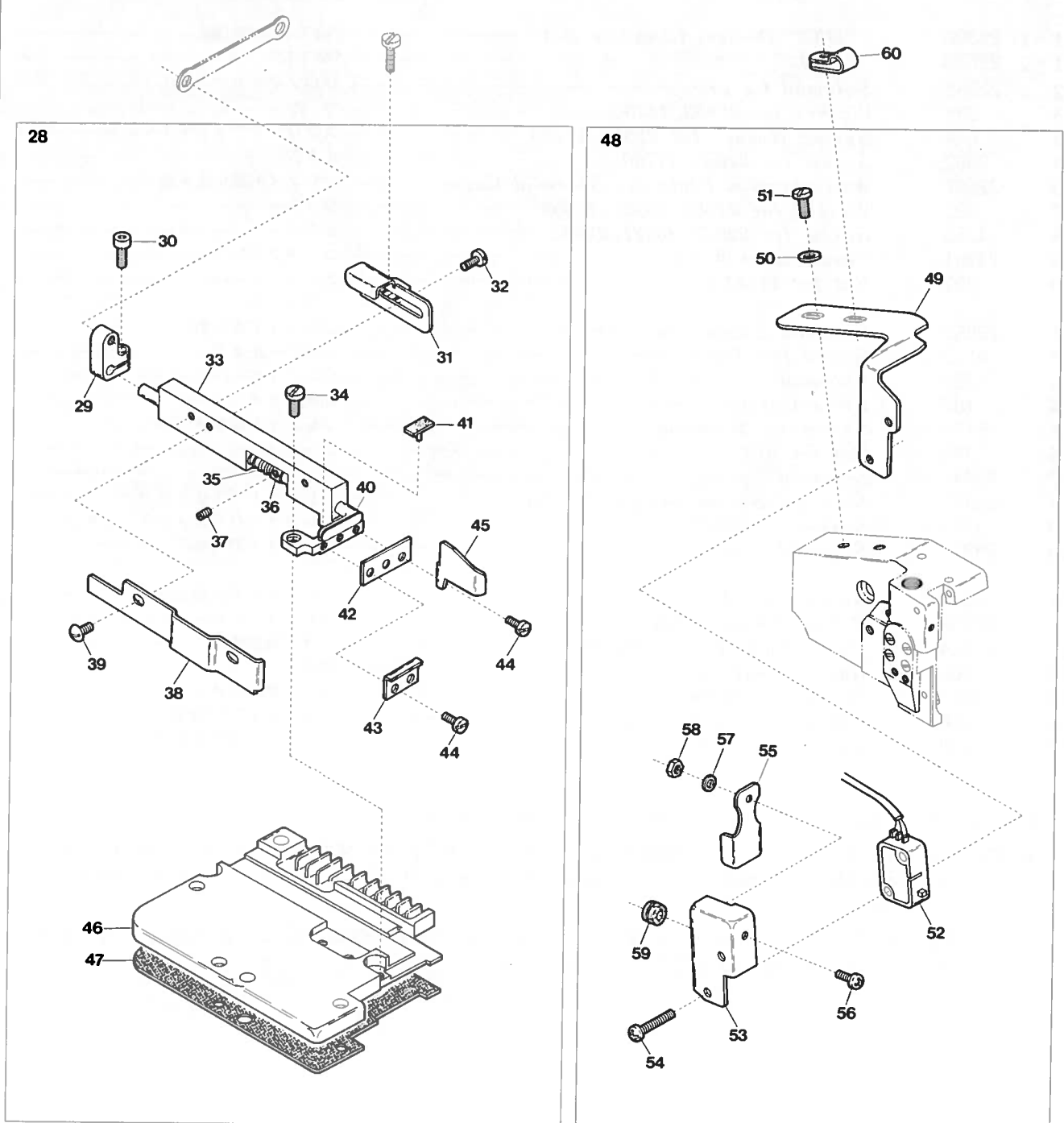

Ref. No.	Parts No.	Description	品名	Amt. Req.
28	23360	Trimming Device, Complete Set	メス装置(組)	1
29	23374	Upper Knife Driving Lever	上メス腕	1
30	5098	Screw for 23374	上メス腕止ネジ	1
31	23367	Upper Knife Holder Stay (Rear)	上メス支エ(後)	1
32	4353	Screw for 23367	上メス支エ(後)止ネジ	2
33	23364	Upper Knife Holder	上メス台	1
34	1203	Screw for 23364	上メス台止ネジ	1
35	23369	Upper Knife Spring	上メスバネ	1
36	23368	Upper Knife Spring Collar	上メスカラー	1
37	3637	Screw for 23368	上メスカラー止ネジ	1
38	23371	Fabric Guide	クロスプレート布案内	1
39	1331	Screw for 23371	クロスプレート布案内止ネジ	2
40	23361	Upper Knife	上メス	1
41	23220	Upper Knife Rubber Cushion	上メスクッション	1
42	23370	Lower Knife	下メス	1
43	23399	Lower Knife Fabric Guide	下メス布案内板	1
44	1230	Screw for 23399, 23372	止ネジ	3
45	23372	Fabric Guide (Small)	布ガイド(小)	1
46	23373	Feed Mechanism Cover	送り台カバー	1
47	21739	Feed Mechanism Cover Gasket	送り台カバーパッキン	1
48	11753	Manual Switch, Complete Set	スイッチ(組)	1
49	22410	Switch Support	スイッチ取付板	1
50	538	Washer for 22410, 94491	ワッシャ	2
51	9150	Screw for 22410, 94491	止ネジ	2
52	11967	Manual Switch	スイッチ	1
53	20989	Manual Switch Cover	スイッチカバー	1
54	9993	Screw for 20989	スイッチカバー止ネジ	2
55	35719	Manual Switch Plate	スイッチ板	1
56	9995	Screw for 35719	スイッチ板止ネジ	1
57	2	Spring Washer for 35719	スプリングワッシャ	1
58	488	Nut for 35719	ナット	1
59	35722	Cord Bushing	コードブッシュ	1
60	94491	Cord Clamp (φ 3.4)	コードクランプ	1
61	23376	Cloth Plate	クロスプレート	1
62-1	11954	Control Box, Complete Set (MT2)	MT制御装置(組)(MT2)	1
62-2	11959	Control Box, Complete Set (MT12)	MT制御装置(組)(MT12)	1
63	11709	Control Box Stay	コントロールボックスステイ	2
64	6910	Wood Screw for 11709	木ネジ	4
65	24046	Stitch Plate Stay	針板支エ	1
66	23378	Feed Mechanism Front Shield (Upper)	送り前カバー(上)	1
67	9143	Screw for 23378	送り前カバー(上)止ネジ	1

"MT2" DEVICE(3)

Z5000

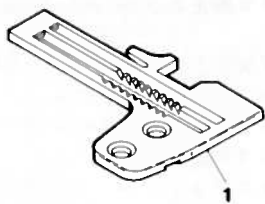

Z5003

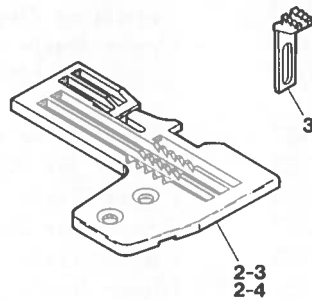
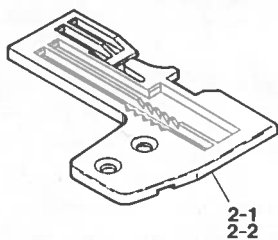

Z5020,5025

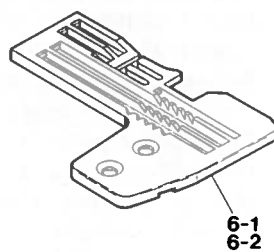
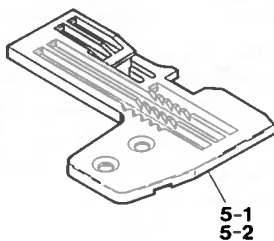
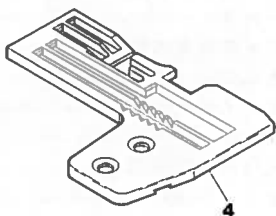

Z5026,5027,5056,5057

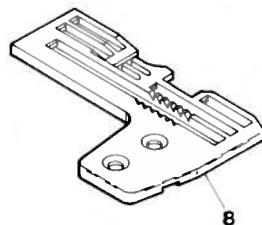
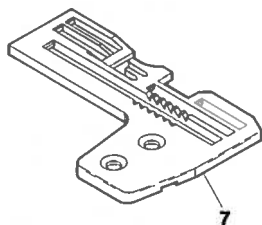

"MT2" DEVICE(3)

<u>Ref.</u> <u>No.</u>	<u>Parts</u> <u>No.</u>	<u>Description</u>	<u>品 名</u>	<u>Amt.</u> <u>Req.</u>
1	22614	Stitch Plate	針板.....	1
2-1	23441	Stitch Plate (O3).....	針板(O3).....	1
2-2	22492	" (O4).....	" (O4).....	1
2-3	23442	" (O5).....	" (O5).....	1
2-4	23443	" (O6).....	" (O6).....	1
3	22956	Auxiliary Feed Dog	小送り.....	1
4	22493	Stitch Plate (X4).....	針板(X4).....	1
5-1	22494	Stitch Plate (X4-4).....	針板(X4-4).....	1
5-2	22495	" (X5-4).....	" (X5-4).....	1
6-1	22497	Stitch Plate (Y5).....	針板(Y5).....	1
6-2	22496	" (Y6).....	" (Y6).....	1
7	22953	Stitch Plate (X4).....	針板(X4).....	1
8	22955	Stitch Plate (Y5).....	針板(Y5).....	1

"MU4", "MU5" DEVICE(1)

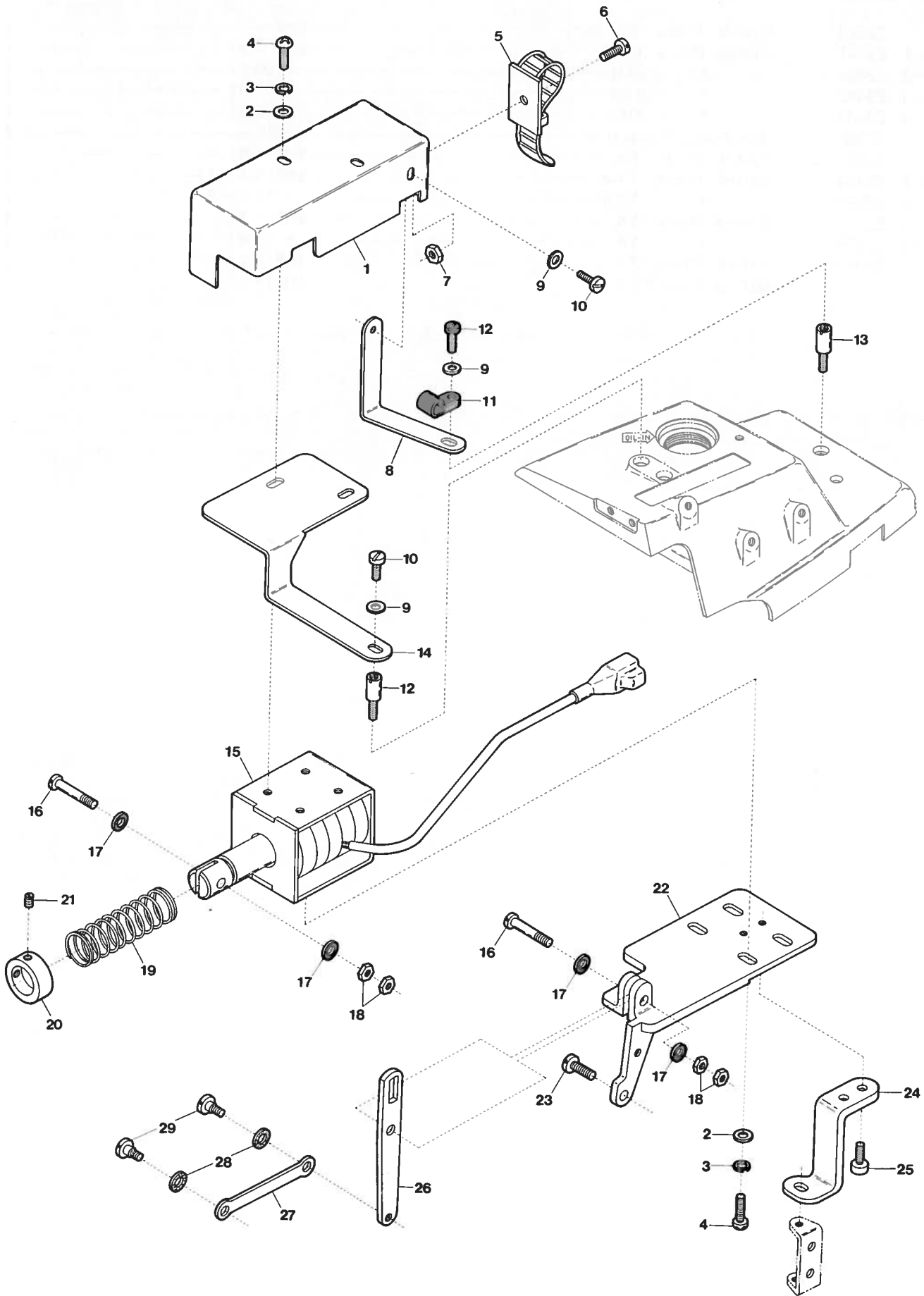

Ref. No.	Parts No.	Description	品名	Amt. Req.
1	23380	Solenoid Cover	ソレノイドカバー	1
2	538	Washer for 23380, 11941	ワッシャ	6
3	644	Spring Washer for 23380, 11941	スプリングワッシャ	6
4	9992	Screw for 23380, 11941	止ネジ	6
5	11987	Cord Clamp (UL Type)	コードクランプ(UL型)	1
6	4352	Screw for 11987	コードクランプ止ネジ	1
7	335	Nut for 11987	ナット	1
8	22687	Anti-vibration Plate for 11941	ソレノイド振れ止め板	1
9	532	Washer for 22687, 22652	ワッシャ	3
10	4353	Screw for 22687, 22652	止ネジ	2
11	36133	Cord Clamp (φ 8.4)	コードクランプ	1
12	4358	Screw for 22687	ソレノイド振れ止め板止ネジ	1
13	4132	Screw for Top Cover	上カバー止ネジ	2
14	22652	Solenoid Supporting Plate	ソレノイド支工板	1
15	11941	Solenoid	ソレノイド	1
16	5127	Solenoid Connecting Rod Pin	連結棒ピン	2
17	187	Fiber Cushion	防振ファイバー	4
18	340	Nut for 5127	ナット	4
19	23447	Solenoid Spring	ソレノイドバネ	1
20	26312	Solenoid Spring Stopper Collar	ソレノイドバネ止メカラー	1
21	3312	Screw for 26312	ソレノイドバネ止メカラー止ネジ	2
22	23375	Solenoid Support	ソレノイド取付板	1
23	4635	Screw for 23375	ソレノイド取付板止ネジ	1
24	20988	Solenoid Support Stay	ソレノイド取付板支工	1
25	5038	Screw for 20988	ソレノイド取付板支工止ネジ	2
26	35298	Solenoid Connecting Lever	ソレノイドレバー	1
27	21484	Upper Knife Connecting Plate	上メス連結板	1
28	568	Rubber Cushion	防振ゴム	2
29	6068	Screw for 21484	上メス連結板止ネジ	2

"MU4", "MU5" DEVICE(2)

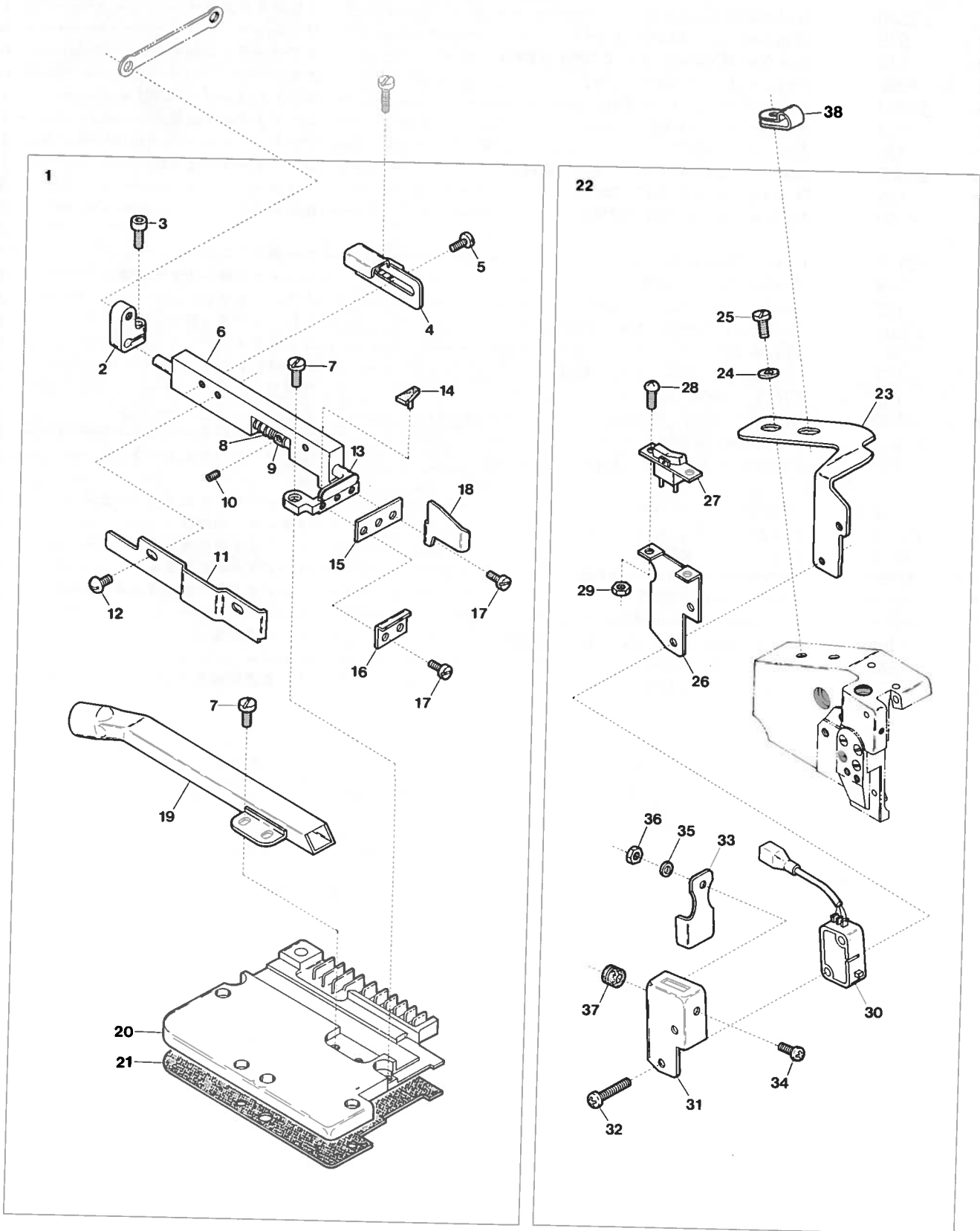

Ref. No.	Parts No.	Description	品名	Amt. Req.
1	23386	Trimming Device, Complete Set	メス装置(組)	1
2	23374	Upper Knife Driving Lever	上メス腕	1
3	5098	Screw for 23374	上メス腕止ネジ	1
4	23367	Upper Knife Holder Stay (Rear)	上メス支工(後)	1
5	4353	Screw for 23367	上メス支工(後)止ネジ	2
6	23364	Upper Knife Holder	上メス台	1
7	1203	Screw for 23364, 23383	止ネジ	3
8	23369	Upper Knife Spring	上メスバネ	1
9	23368	Upper Knife Spring Collar	上メスカラー	1
10	3637	Screw for 23368	上メスカラー止ネジ	1
11	23371	Fabric Guide	クロスプレート布案内	1
12	1331	Screw for 23371	クロスプレート布案内止ネジ	2
13	23361	Upper Knife	上メス	1
14	23220	Upper Knife Rubber Cushion	上メスクッション	1
15	23370	Lower Knife	下メス	1
16	23399	Lower Knife Fabric Guide	下メス布案内板	1
17	1230	Screw for 23399, 23372	止ネジ	3
18	23372	Fabric Guide (Small)	布ガイド(小)	1
19	23383	Suction Pipe	吸込管	1
20	23373	Feed Mechanism Cover	送り台カバー	1
21	21739	Feed Mechanism Cover Gasket	送り台カバーパッキン	1
22	11926	Manual Switch, Complete Set	スイッチ(組)	1
23	22410	Switch Support	スイッチ取付板	1
24	538	Washer for 22410, 94491	ワッシャ	2
25	9150	Screw for 22410, 94491	止ネジ	2
26	23397	Supplementary Switch Support	補助スイッチ取付板	1
27	11928	Supplementary Switch	補助スイッチ	1
28	—	Screw for 11928	補助スイッチ止ネジ	2
29	—	Nut for 11928	ナット	2
30	11754	Manual Switch	スイッチ	1
31	23382	Manual Switch Cover	スイッチカバー	1
32	9993	Screw for 23382	スイッチカバー止ネジ	2
33	35719	Manual Switch Plate	スイッチ板	1
34	9995	Screw for 35719	スイッチ板止ネジ	1
35	2	Spring Washer for 35719	スプリングワッシャ	1
36	488	Nut for 35719	ナット	1
37	35722	Cord Bushing	コードブッシュ	1
38	94491	Cord Clamp (φ 3.4)	コードクランプ	1

"MU4", "MU5" DEVICE(3)

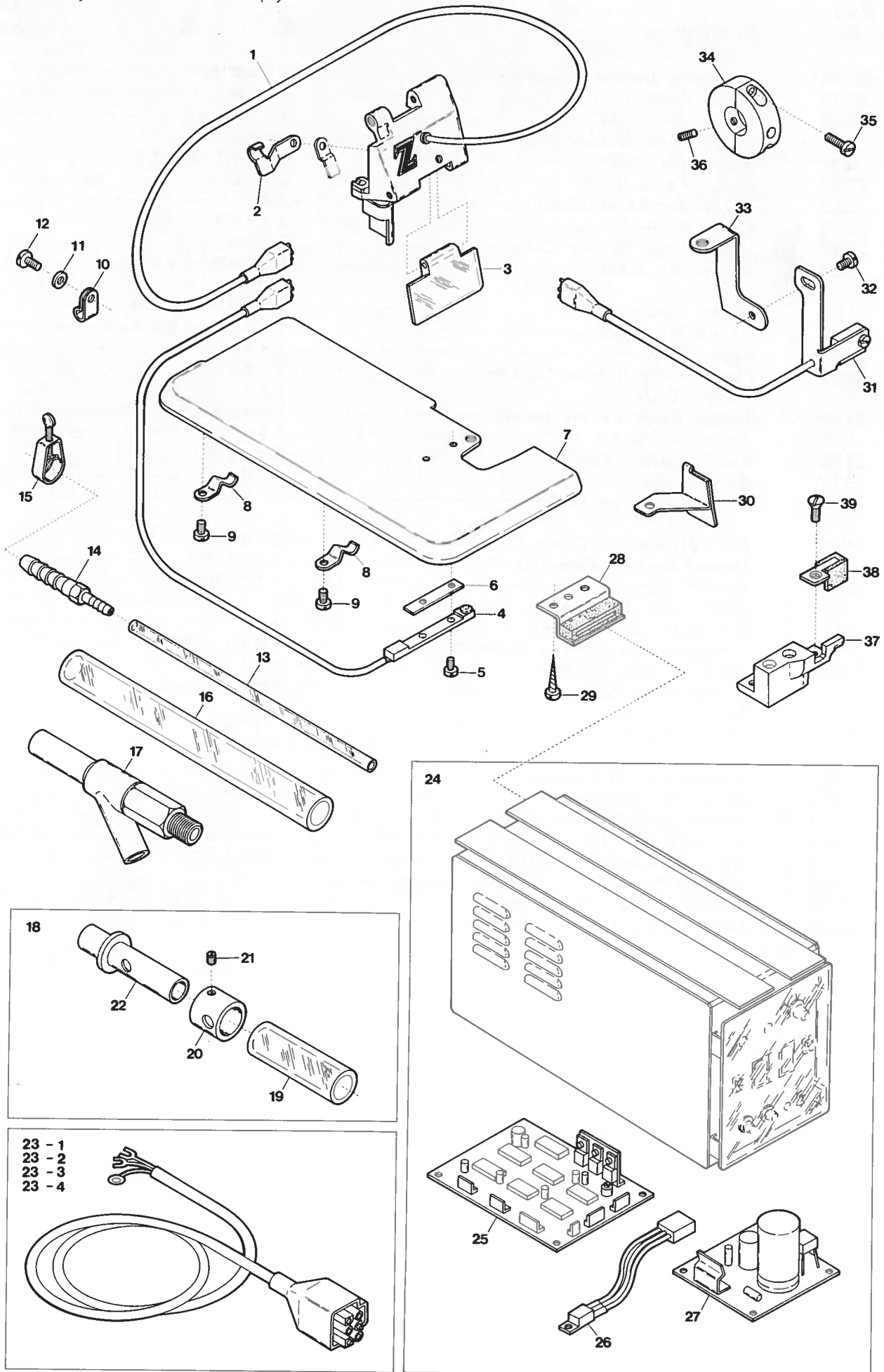

Ref. No.	Parts No.	Description	品名	Amt. Req.
1	11934	Photocell Holder Unit	投光器(組)	1
2	23412	Cord Stay Plate	コード支工板	1
3	23175	Safety Plate	アイガード	1
4	11935	Emission Catcher Unit	受光器(組)	1
5	4404	Screw for 11935	受光器(組)止ネジ	2
6	11949	Insulating Plate	絶縁板	1
7	23197	Cloth Plate	クロスプレート	1
8	23393	Cord Stay	コード支工	2
9	4401	Screw for 23393	コード支工止ネジ	2
10	94491	Cord Clamp (φ 3.4)	コードクランプ	1
11	542	Washer for 94491	ワッシャー	1
12	9853	Screw for 94491	コードクランプ止ネジ	1
13	22404	Nylon Hose (3.8×6×1000mm)	ナイロンホース	1
14	33932	Joint	ジョイント	1
15	33939	Hose Band (1/4 inch)	ホースバンド	1
16	22392	Nylon Hose (12×18×1000mm)	ナイロンホース	1
17	10100	Venturi Pipe	ベンチュリ管	1
18	21451	Suction Power Control Tube, Complete Set	吸引力調整管(組)	1
19	21450	Nylon Hose (12×16×50mm)	ナイロンホース	1
20	21456	Suction Power Control Tube	吸引力調整管	1
21	1892	Screw for 21456	吸引力調整管止ネジ	1
22	21457	Suction Power Control Tube (Inner)	吸引力調整台	1
23-1	11943	Power Cord (for 100 Voltage)	電源コード (100V用)	1
23-2	11944	“ (“ 200 “)	“ (200 “)	1
23-3	11945	“ (“ 220 “)	“ (220 “)	1
23-4	11946	“ (“ 380 “)	“ (380 “)	1
24	11930	Control Box, Complete Set	制御装置(組)	1
25	11975	Control Board	MU制御基板	1
26	11974	Voltage Regulator	定電圧IC	1
27	11973	Power Board	MU電源基板	1
28	11709	Control Box Stay	制御ボックスステイ	4
29	6910	Screw for 11709	制御ボックスステイ止ネジ	8
30	22635	Lower Looper Cover	下ルーバカバー	1
31	11933	IC Unit (DN834)	ホールIC(組)	1
32	5506	Screw for 11933	ホールIC(組)止ネジ	1
33	21539	IC Unit Supporting Plate	IC装置取付板支工	1
34	23179	Magnet Holding Ring Unit	マグネット取付台(組)	1
35	7609	Screw for 23179	マグネット取付台(組)止ネジ	2
36	9209	Screw for 23179	マグネット取付台(組)止ネジ	1
37	24046	Stitch Plate Stay	針板支工	1
38	23378	Feed Mechanism Front Shield (Upper)	送り前カバー(上)	1
39	9143	Screw for 23378	送り前カバー(上)止ネジ	1

"MU4", MU5" DEVICE(4)

Z5003

- 1-1
- 1-2
- 1-3
- 1-4

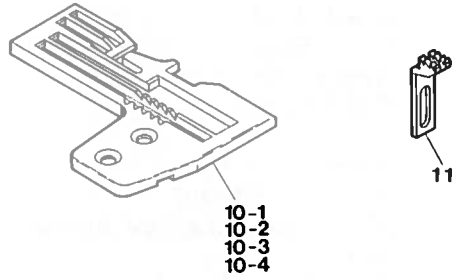
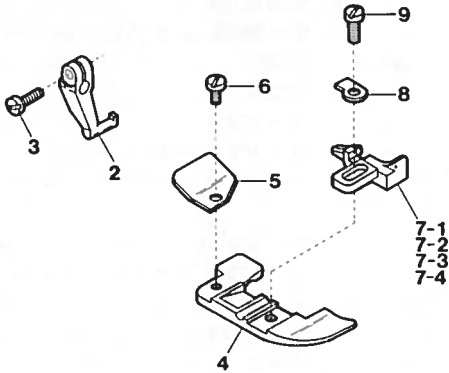

Z5020

- 12-1
- 12-2
- 12-3
- 12-4

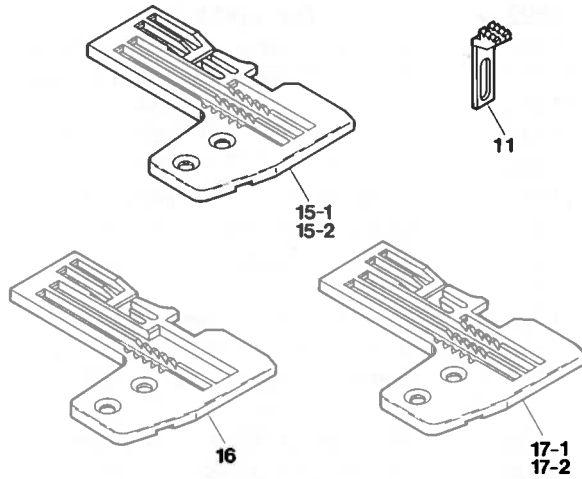
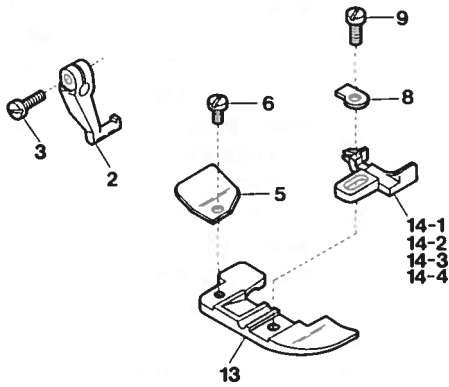

Z5025

- 18-1
- 18-2
- 18-3
- 18-4

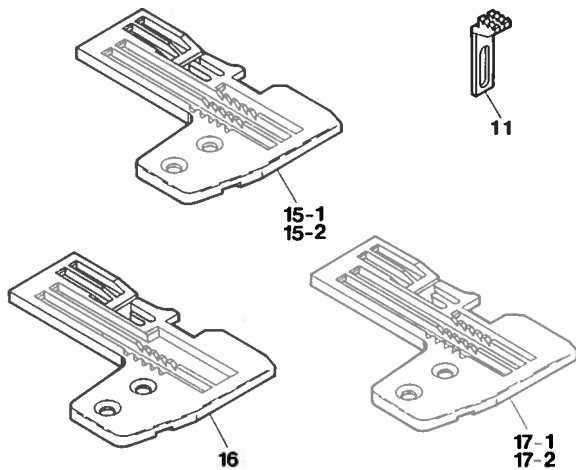
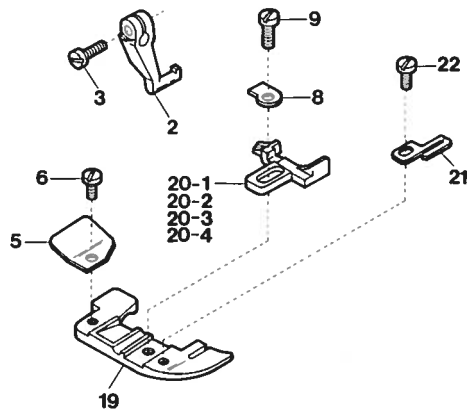

Ref. No.	Parts No.	Description	品名	Amt. Req.
1-1	23016	Presser Foot, Complete Set (03)	押エ(組)	1
1-2	23018	” ” (04)	”	1
1-3	23020	” ” (05)	”	1
1-4	23022	” ” (06)	”	1
2	21938	Presser Foot Hinge	押エヒンジ	1
3	4351	Screw for 21938	押エヒンジ止ネジ	1
4	21967	Presser Foot (Lower)	押エ(下)	1
5	22416	Presser Foot Chain Shield	空糸押エ	1
6	1228	Screw for 22416	空糸押エ止ネジ	1
7-1	21871	Presser Foot Stitch Tongue (03)	爪	1
7-2	21872	” ” (04)	”	1
7-3	21873	” ” (05)	”	1
7-4	21874	” ” (06)	”	1
8	21005	Presser Foot Hinge	押エヒンジバネ	1
9	4131	Screw for 21005	押エヒンジバネ止ネジ	1
10-1	23441	Stitch Plate (03)	針板	1
10-2	22492	” (04)	”	1
10-3	23442	” (05)	”	1
10-4	23443	” (06)	”	1
11	22956	Auxiliary Feed Dog	小送り	1
12-1	23046	Presser Foot, Complete Set (X4), (X4-4)	押エ(組)	1
12-2	23048	” ” (X5-4)	”	1
12-3	23050	” ” (Y5)	”	1
12-4	23052	” ” (Y6)	”	1
13	21967	Presser Foot (Lower)	押エ(下)	1
14-1	21870	Presser Foot Stitch Tongue (X4), (X4-4)	爪	1
14-2	22600	” ” (X5-4)	”	1
14-3	21864	” ” (Y5)	”	1
14-4	21865	” ” (Y6)	”	1
15-1	22497	Stitch Plate (Y5)	針板	1
15-2	22496	” (Y6)	”	1
16	22493	Stitch Plate (X4)	針板	1
17-1	22494	Stitch Plate (X4-4)	針板	1
17-2	22495	” (X5-4)	”	1
18-1	23068	Presser Foot, Complete Set (X4), (X4-4)	押エ(組)	1
18-2	23070	” ” (X5-4)	”	1
18-3	23072	” ” (Y5)	”	1
18-4	23074	” ” (Y6)	”	1
19	22064	Presser Foot (Lower)	押エ(下)	1
20-1	22605	Presser Foot Stitch Tongue (X4), (X4-4)	爪	1
20-2	22606	” ” (X5-4)	”	1
20-3	21866	” ” (Y5)	”	1
20-4	21867	” ” (Y6)	”	1
21	21065	Presser Foot Tape Guide	押エテープガイド	1
22	1230	Screw for 21065	押エテープガイド止ネジ	1

"MU5" DEVICE(5)

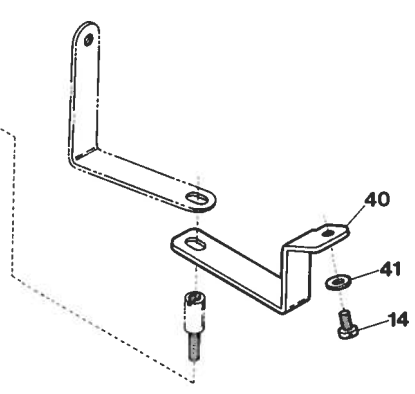
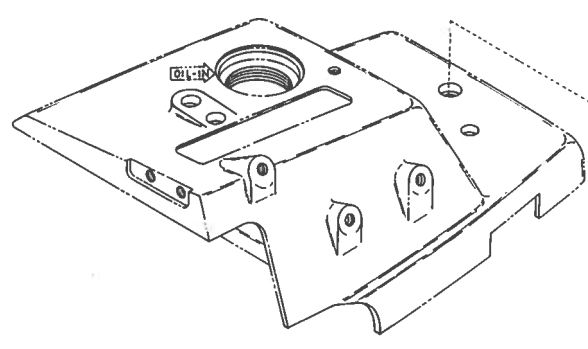
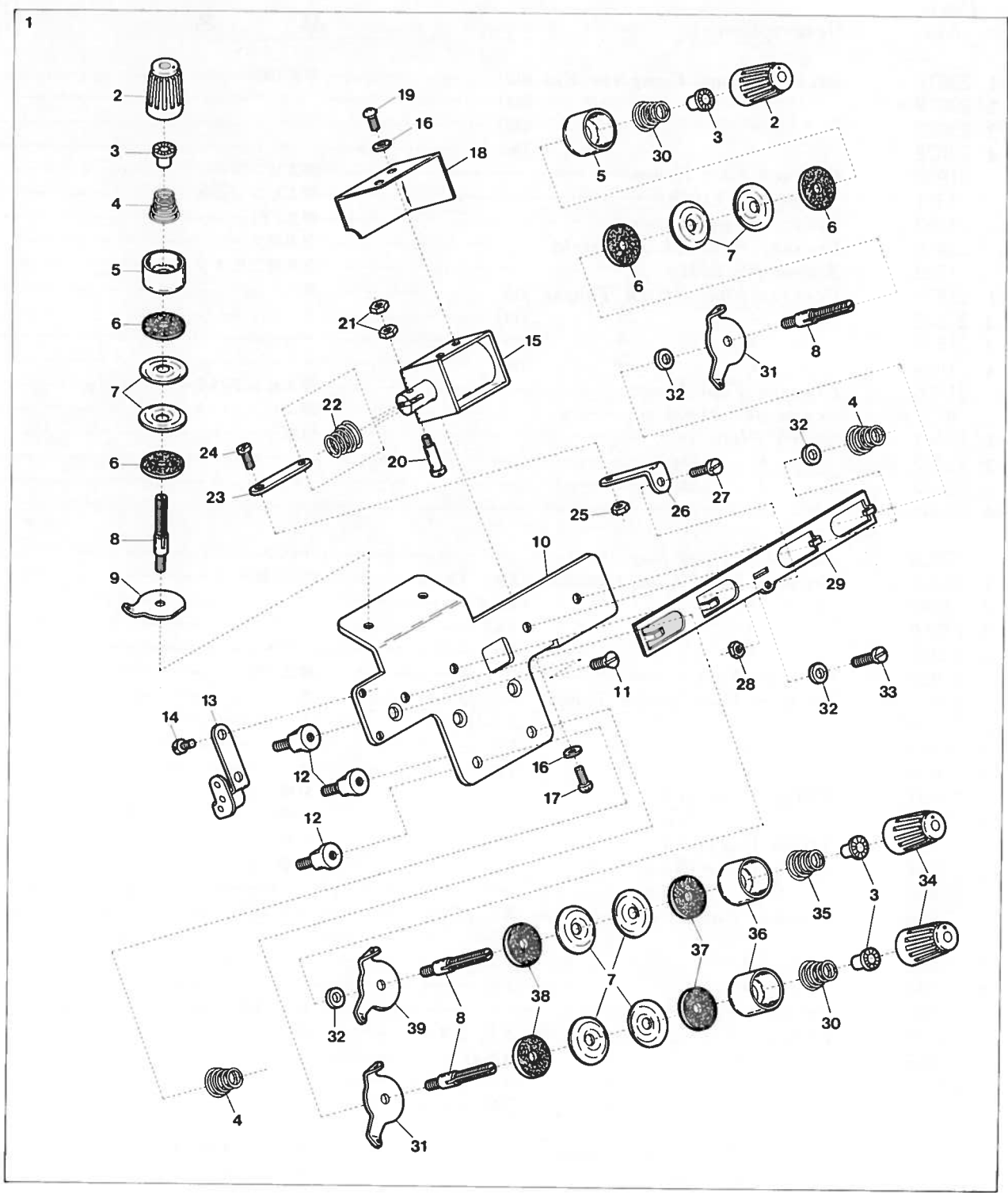

Ref. No.	Parts No.	Description	品名	Amt. Req.
1	23490	Thread Tension Release, Complete Set	糸緩メ装置(組)	1
2	33806	Thread Tension Spring Cap	糸調子バネキャップ(上)	3
3	33890	Thread Tension Spring Bushing	糸調子ナット回り止メ	6
4	20103	Thread Tension Spring	糸調子バネ	3
5	33807	Thread Tension Spring Retainer	糸調子バネキャップ(下)	3
6	286	Felt for 31111	フェルト	6
7	31111	Tension Disc	糸調子皿	12
8	7904	Tension Post	糸調子棒	6
9	36853	Tension Disc Eyelet	調子台糸道	1
10	23185	Thread Tension Release Supporting Board	糸緩メ台	1
11	1396	Screw for 23185	糸緩メ台止ネジ	1
12	4151	Screw for 23185	糸緩メ台取付ケネジ	3
13	23188	Tension Disc Auxiliary Eyelet	調子台補助糸道	1
14	4358	Screw for 23188, 23191	止ネジ	3
15	11942	Thread Tension Release Solenoid	ソレノイド	1
16	14	Washer for 11942, 23189	ワッシャ	4
17	9994	Screw for 11942	ソレノイド止ネジ	2
18	23189	Solenoid Cover	ソレノイドカバー	1
19	9995	Screw for 23189	ソレノイドカバー止ネジ	2
20	5128	Solenoid Connecting Pin	ソレノイド連結ピン	1
21	21	Nut for 5128	ナット	2
22	32971	Solenoid Spring	ソレノイドバネ	1
23	23187	Thread Tension Release Link	糸緩メリンク	1
24	6092	Screw for 23187	糸緩メリンク止ネジ	1
25	330	Nut for 23187	ナット	1
26	23186	Thread Tension Release Plate Guide	糸緩メ板ガイド	1
27	4312	Screw for 23186	糸緩メ板ガイド止ネジ	1
28	331	Nut for 23186	ナット	1
29	23190	Thread Tension Release Plate	糸緩メ板	1
30	20102	Thread Tension Spring	糸調子バネ	2
31	20101	Tension Disc Eyelet	調子台糸道	4
32	496	Spacer for 20101, 21001	スペーサ	4
33	9843	Screw for 496	スペーサ止ネジ	1
34	20104	Thread Tension Spring Cap	糸調子バネキャップ(上)	3
35	20132	Thread Tension Spring	糸調子バネ	1
36	20118	Thread Tension Spring Retainer	糸調子バネキャップ(下)	3
37	178	Felt for 31111	フェルト	3
38	177	Felt for 31111	フェルト	3
39	21001	Tension Disc Eyelet	調子台糸道	1
40	23191	Solenoid Stay	ソレノイド支工	1
41	532	Washer for 23191	ワッシャ	1

"MU5" DEVICE(6)

1

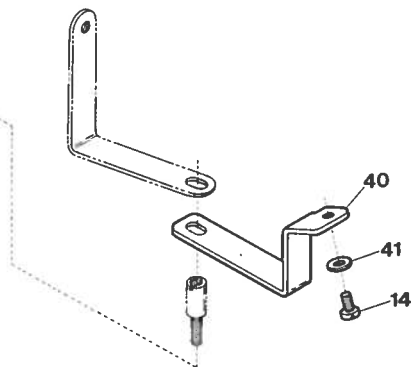
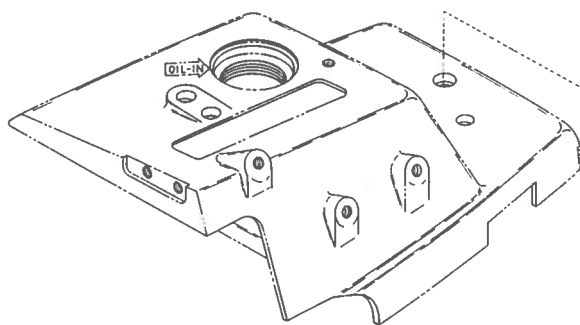
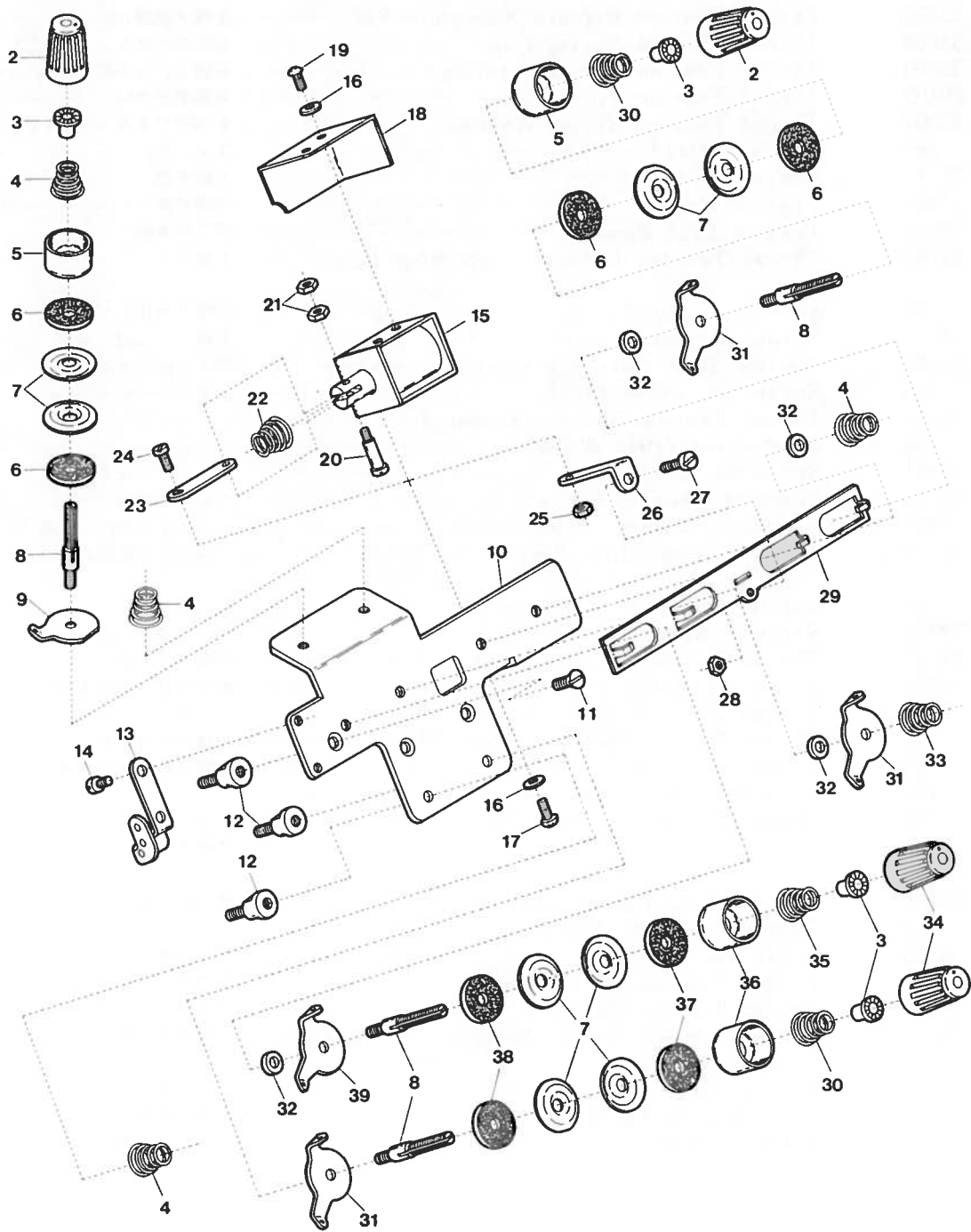

Ref. No.	Parts No.	Description	品名	Amt. Req.
1	23491	Thread Tension Release, Complete Set	糸緩メ装置(組)	1
2	33806	Thread Tension Spring Cap	糸調子バネキャップ(上)	4
3	33890	Thread Tension Spring Bushing	糸調子ナット回り止メ	8
4	20103	Thread Tension Spring	糸調子バネ	4
5	33807	Thread Tension Spring Retainer	糸調子バネキャップ(下)	4
6	286	Felt for 31111	フェルト	8
7	31111	Tension Disc	糸調子皿	16
8	7904	Tension Post	糸調子棒	8
9	36853	Tension Disc Eyelet	調子台糸道	2
10	23185	Thread Tension Release Supporting Board	糸緩メ台	1
11	1396	Screw for 23185	糸緩メ台止ネジ	1
12	4151	Screw for 23185	糸緩メ台取付ケネジ	3
13	23188	Tension Disc Auxiliary Eyelet	調子台補助糸道	1
14	4358	Screw for 23188, 23191	止ネジ	3
15	11942	Thread Tension Release Solenoid	ソレノイド	1
16	14	Washer for 11942, 23189	ワッシャ	4
17	9994	Screw for 11942	ソレノイド止ネジ	2
18	23189	Solenoid Cover	ソレノイドカバー	1
19	9995	Screw for 23189	ソレノイドカバー止ネジ	2
20	5128	Solenoid Connecting Pin	ソレノイド連結ピン	1
21	21	Nut for 5128	ナット	2
22	32971	Solenoid Spring	ソレノイドバネ	1
23	23187	Thread Tension Release Link	糸緩メリンク	1
24	6092	Screw for 23187	糸緩メリンク止ネジ	1
25	330	Nut for 23187	ナット	1
26	23186	Thread Tension Release Plate Guide	糸緩メ板ガイド	1
27	4312	Screw for 23186	糸緩メ板ガイド止ネジ	1
28	331	Nut for 23186	ナット	1
29	23190	Thread Tension Release Plate	糸緩メ板	1
30	20102	Thread Tension Spring	糸調子バネ	2
31	20101	Tension Disc Eyelet	調子台糸道	5
32	496	Spacer for 20101, 21001	スペーサ	4
33	20132	Thread Tension Spring	糸調子バネ	1
34	20104	Thread Tension Spring Cap	糸調子バネキャップ(上)	4
35	30255	Thread Tension Spring	糸調子バネ	1
36	20118	Thread Tension Spring Retainer	糸調子バネキャップ(下)	4
37	178	Felt for 31111	フェルト	4
38	177	Felt for 31111	フェルト	4
39	21001	Tension Disc Eyelet	調子台糸道	1
40	23191	Solenoid Stay	ソレノイド支エ	1
41	532	Washer for 23191	ワッシャ	1

"CH20" DEVICE (1)

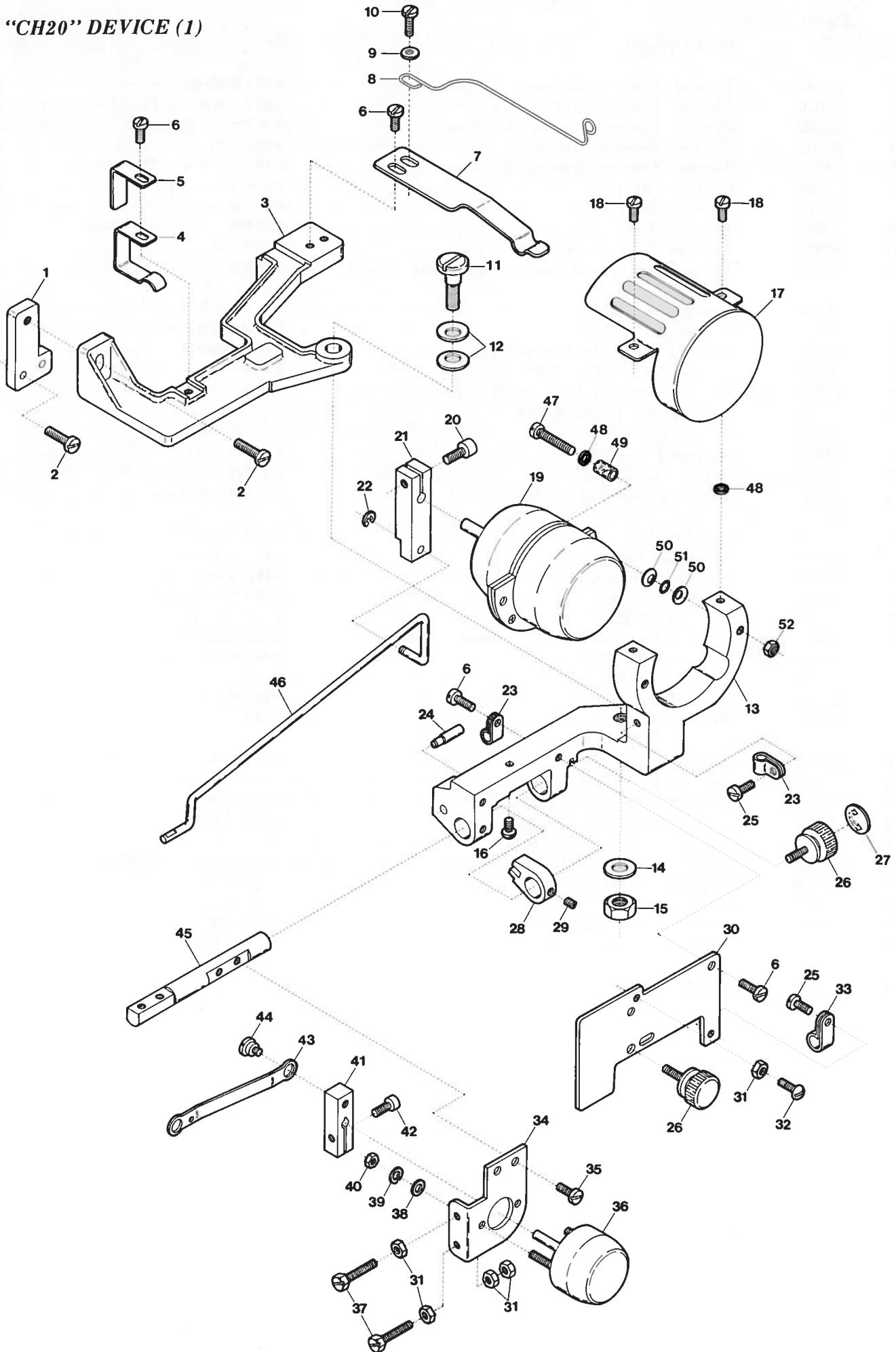

Ref. No.	Parts No.	Description	品名	Amt. Req.
1	23714	Device Supporting Plate	装置取付板	1
2	9150	Screw for 23714, 23726	止ネジ	4
3	23726	Device Holder Base	装置取付台	1
4	23750	Device Holder Base Fixing Spring Plate	装置取付台固定バネ	1
5	23763	Supplementary Fixing Spring Plate	補助バネ	1
6	4353	Screw for 23750, 23715, 94491, 23717	止ネジ	5
7	23715	Solenoid Holder Fixing Spring Plate	ソレノイド取付台固定バネ	1
8	23769	Fixing Spring for 23700	定規連結軸固定バネ	1
9	533	Washer for 23769	ワッシャ	1
10	1175	Screw for 23769	固定バネ止ネジ	1
11	5589	Screw for 23725	ソレノイド取付台止ネジ	1
12	621	Spring Washer for 23725	スプリングワッシャ	2
13	23725	Solenoid Holder	ソレノイド取付台	1
14	613	Washer for 23725	ワッシャ	1
15	306	Nut for 23725	ナット	1
16	1333	Stopper Screw for 23750	固定バネストップバネジ	1
17	23752	Rotary Solenoid Cover	ロータリソレノイドカバー	1
18	5000	Screw for 23752	ソレノイドカバー止ネジ	2
19	11190	Rotary Solenoid (Large)	ロータリソレノイド(大)	1
20	5550	Screw for 36111	定規運動レバー止ネジ	1
21	36111	Hemming Guide Interlocking Lever	定規運動レバー	1
22	36132	Retaining Ring	ストップリング	1
23	94491	Cord Clamp (φ 3.4)	コードクランプ	2
24	23711	Guide Pin for 23723	ガイドピン	1
25	4358	Screw for 94491, 36133	コードクランプ止ネジ	2
26	5585	Adjusting Screw for 23713	定規台取付軸調節ネジ	2
27	1049	Sticker	貼りマーク	1
28	23723	Guide Collar for 23713	ガイドカラー	1
29	3638	Screw for 23723	ガイドカラー止ネジ	1
30	23717	Solenoid Holder Cover	ソレノイド取付台カバー	1
31	355	Lock Nut for 4352, 7606	ロックナット	5
32	4352	Positioning Screw for 23707	スライド定規位置決めネジ	1
33	36133	Cord Clamp (φ 8.4)	コードクランプ	1
34	23722	Solenoid Supporting Plate	ソレノイド取付板	1
35	4406	Screw for 23722	ソレノイド取付板止ネジ	2
36	11191	Rotary Solenoid (Small)	ロータリソレノイド(小)	1
37	7606	Adjusting Screw for 23718	スライド定規レバー調節ネジ	2
38	14	Washer for 11191	ワッシャ	2
39	2	Spring Washer for 11191	スプリングワッシャ	2
40	12	Nut for 11191	ナット	2
41	23718	Edge Guide Interlocking Lever	スライド定規レバー	1
42	5038	Screw for 23718	スライド定規レバー止ネジ	1
43	23712	Edge Guide Interlocking Plate	スライド定規連結棒	1
44	5588	Screw for 23712	スライド定規連結棒止ネジ	1
45	23713	Edge Guide Holding Shaft	定規台取付軸	1
46	23700	Hemming Guide Interlocking Shaft	定規連結軸	1
47	9931	Screw for 11190	ロータリソレノイド(大)止ネジ	2
48	550	Fiber Cushion for 23752, 11190	防振ファイバ	4
49	23799	Cushion (Vinyl) for 11190	ソレノイドクッション	2
50	10	Spring Washer for 11190	スプリングワッシャ	4
51	20538	Rubber Cushion	防振ゴム	2
52	334	Nut for 11190	ナット	2

"CH20" DEVICE (2)

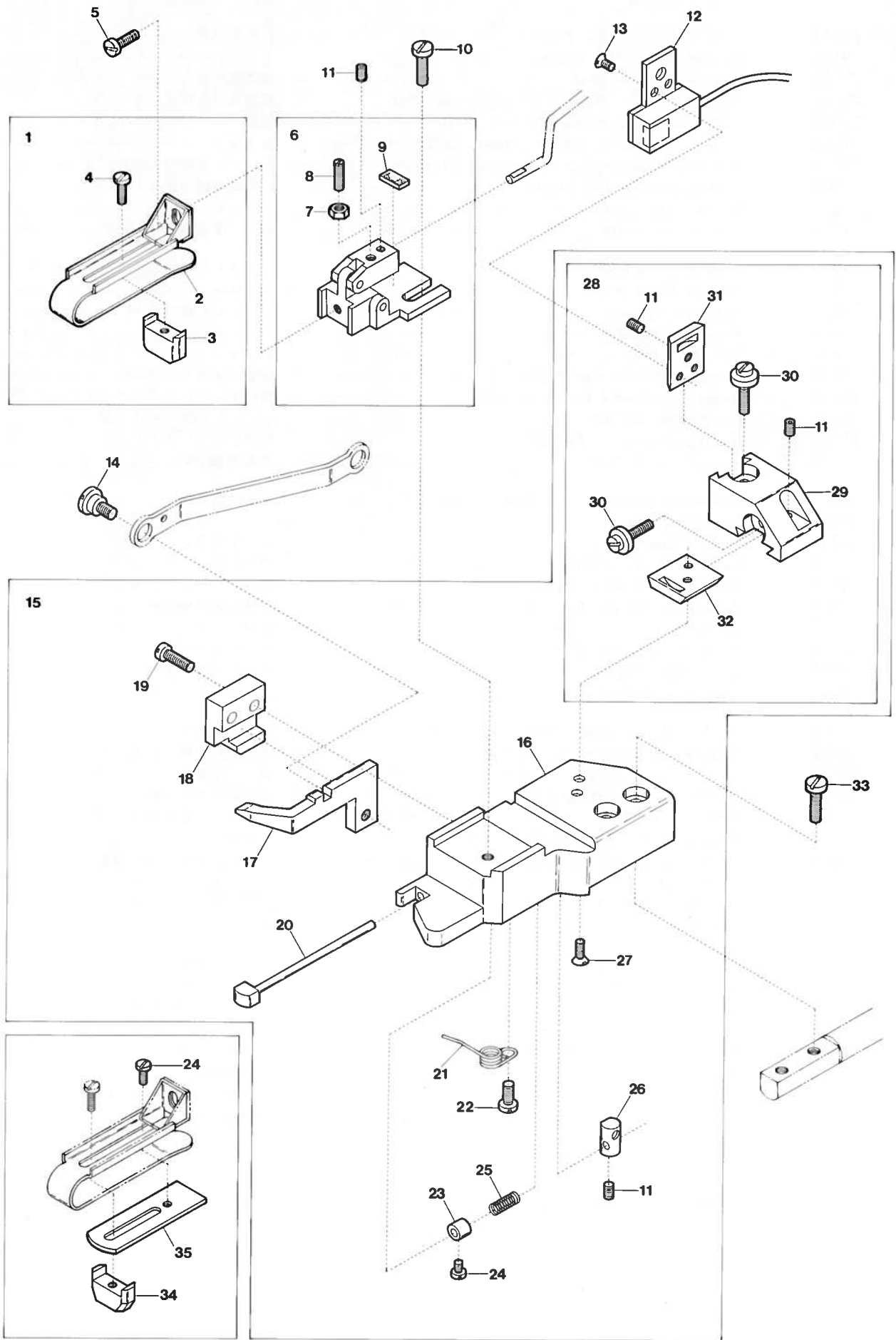

Ref. No.	Parts No.	Description	品名	Amt. Req.
1	23740	Blind-Hemming Guide, Complete Set	定規(組)	1
2	23739	Blind-Hemming Guide	定規	1
3	23741	Hemming Positioner	裾引幅調節片	1
4	4236	Screw for 23741	裾引幅調節片止ネジ	1
5	5036	Screw for 23739	定規止ネジ	1
6	23744	Hemming Guide Bracket, Complete Set	定規調節台(組)	1
7	335	Lock Nut for 6820	ロックナット	1
8	6820	Adjusting Screw for 23744	調節ネジ	1
9	36161	Anti-Shock Rubber	定規緩衝ゴム	1
10	1202	Screw for 23744	定規調節台(組)止ネジ	1
11	3637	Screw for 23700, 23756, 23704, 23703	止ネジ	4
12	23745	IC, Complete Set	IC装置(組)	1
13	4139	Screw for 23745	IC装置(組)止ネジ	2
14	5598	Screw for 23712	スライド定規連結桿止ネジ	1
15	23747	Blind-Hemming Edge Guide, Complete Set	定規台(組)	1
16	23724	Blind-Hemming Edge Guide	定規台	1
17	23707	Slide Edge Guide	スライド定規	1
18	23705	Slide Edge Guide Holder	スライド定規受ケ	1
19	7609	Screw for 23705	スライド定規受ケ止ネジ	2
20	23708	Sensor	感知子	1
21	23737	Slide Edge Guide Pressing Spring	スライド定規戻シバネ	1
22	4351	Screw for 23737	スライド定規戻シバネ止ネジ	1
23	23709	Sensor Adjusting Collar	感知子調節カラー	1
24	4237	Screw for 23709, 23768	止ネジ	2
25	23710	Sensor Spring	感知子戻シバネ	1
26	23756	Magnet Unit	マグネット(組)	1
27	1399	Screw for 23703	左右スライド板止ネジ	2
28	23754	IC Positioner, Complete Set	IC調節台(組)	1
29	23701	IC Positioner	IC調節台	1
30	5591	Adjusting Screw for 23704, 23703	スライド板調節ネジ	2
31	23704	Vertically Sliding Plate	上下スライド板	1
32	23703	Raterally Sliding Plate	左右スライド板	1
33	4440	Screw for 23724	定規台止ネジ	2
34	23767	Hemming Positioner (for Light Materials)	裾引幅調節片(薄物用)	1
35	23768	Spacer for 23739 (for Light Materials)	定規スペーサ(薄物用)	1

"CH20" DEVICE (3)

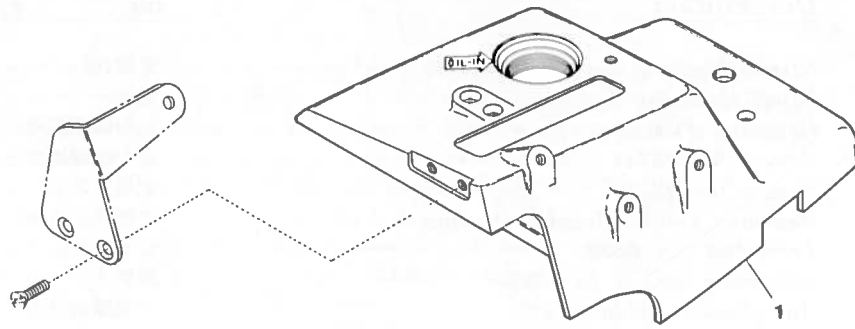

2

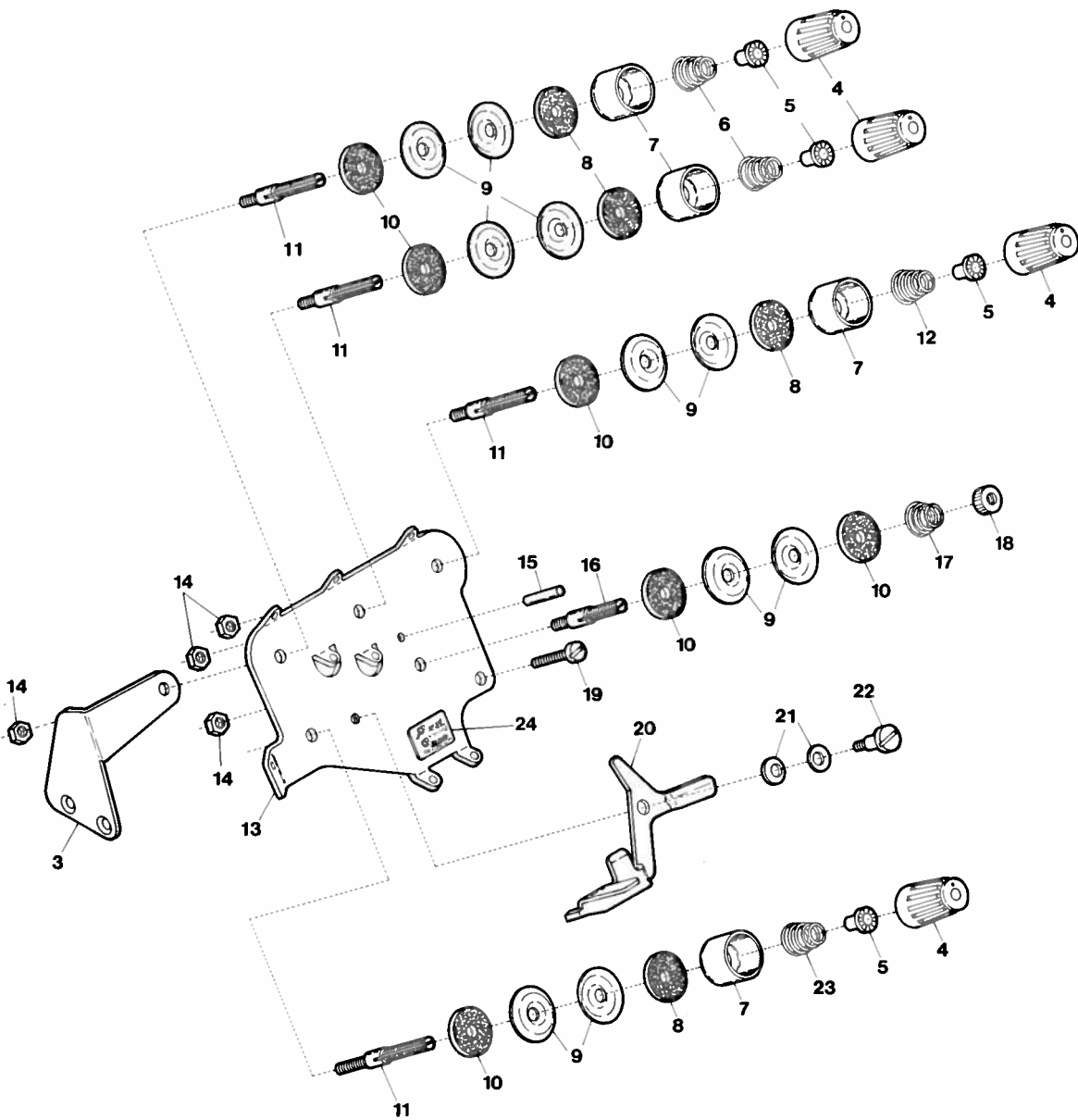

Ref. No.	Parts No.	Description	品名	Amt. Req.
1	23727	Top Cover	上カバー.....	1
2	23776	Tension Change Device, Complete Set	T C 装置(組).....	1
3	23729	Tension Disc Eyelet Steady Plate	調子台糸道振止メ.....	1
4	20104	Thread Tension Spring Cap	糸調子バネキャップ(上).....	4
5	33890	Thread Tension Spring Bushing	糸調子ナット回り止メ.....	4
6	20103	Thread Tension Spring	糸調子バネ.....	2
7	20118	Thread Tension Spring Retainer	糸調子バネキャップ(下).....	4
8	178	Felt for 31111	フェルト.....	4
9	31111	Tension Disc	糸調子皿.....	10
10	177	Felt for 31111	フェルト.....	6
11	7904	Tension Post	糸調子棒.....	4
12	20102	Thread Tension Spring	糸調子バネ.....	1
13	23732	Thread Tension Disc Eyelet	調子台糸道.....	1
14	334	Nut for 7904	ナット.....	4
15	23766	Thread Guide Pin	糸ガイドピン.....	1
16	1904	Tension Post	糸調子棒.....	1
17	37114	Thread Tension Spring	糸調子バネ.....	1
18	56	Adjusting Nut for 37114	調節ナット.....	1
19	4406	Screw for 23732	調子台糸道止ネジ.....	1
20	23728	Tension Change Lever	T C レバー.....	1
21	10	Spring Washer for 23728	スプリングワッシャ.....	2
22	4100	Screw for 23728	T C レバー止ネジ.....	1
23	20132	Thread Tension Spring	糸調子バネ.....	1
24	622	Sticker	貼りマーク.....	1

"CH20" DEVICE (4)

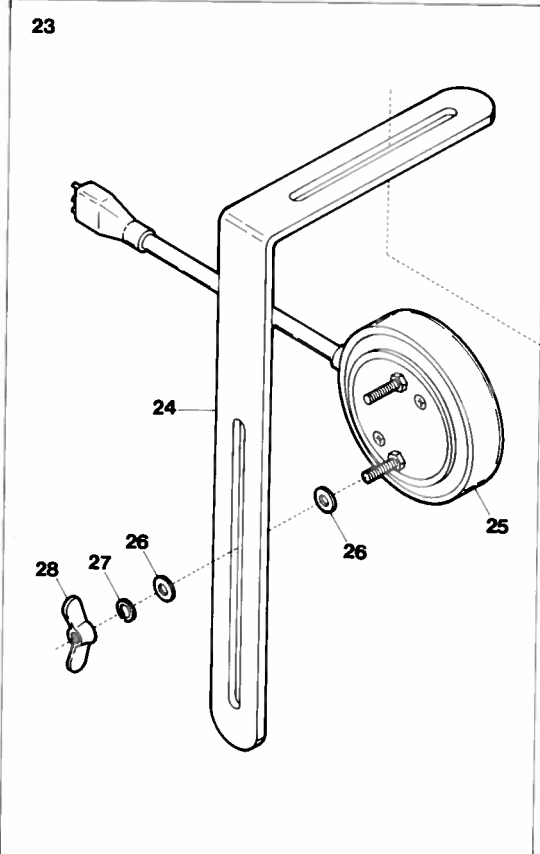
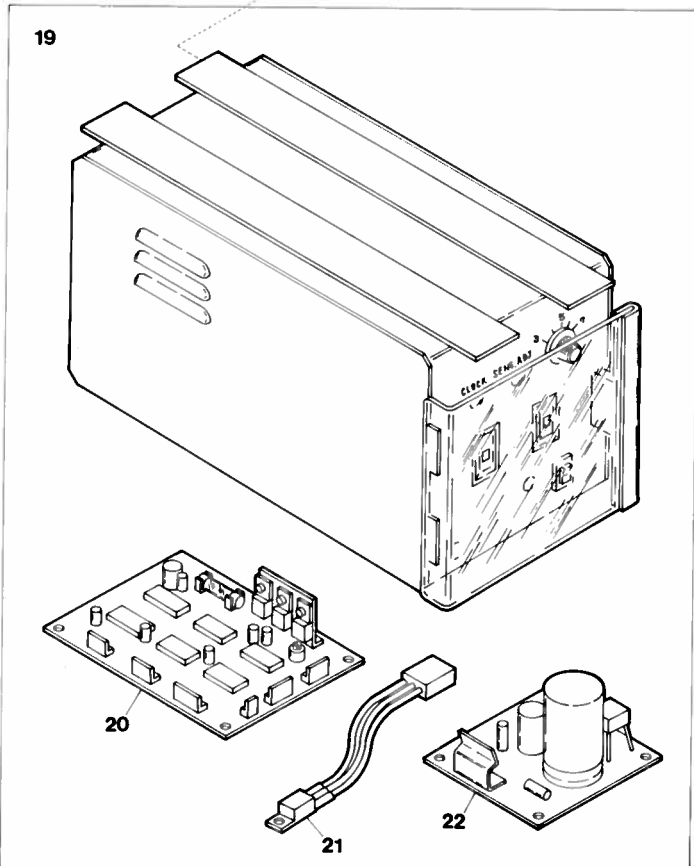
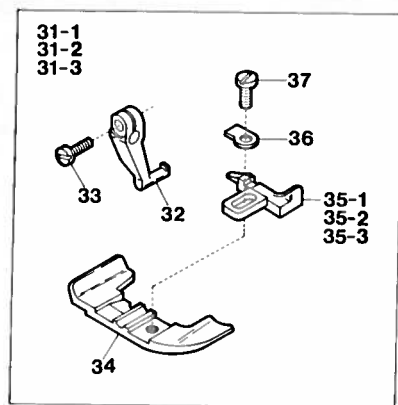
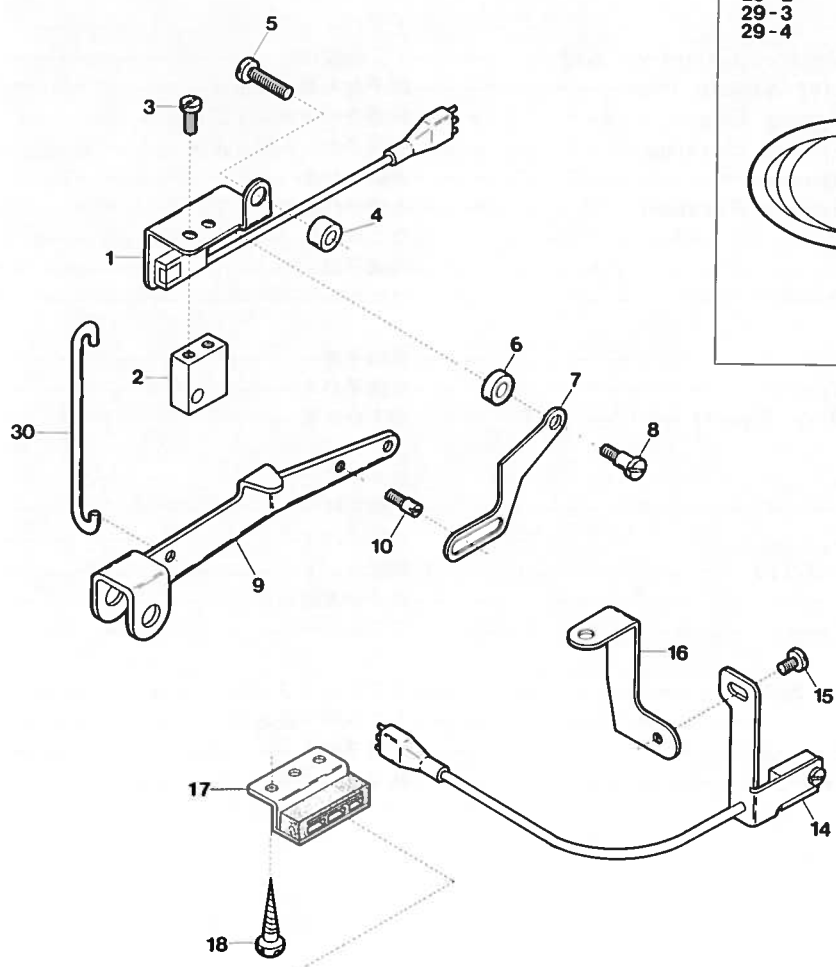
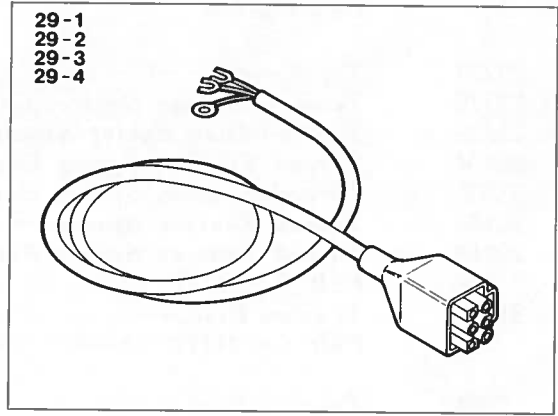

Ref. No.	Parts No.	Description	品名	Amt. Req.
1	11193	Presser Foot Switch	押エスイッチ	1
2	23734	Magnet for Presser Foot Switch	マグネット	1
3	4353	Screw for 23734	マグネット止ネジ	2
4	185	Spacer for 11193	スペーサ	1
5	9930	Screw for 11193	押エスイッチ止ネジ	1
6	23720	Switch Plate Spacer	スイッチ板スペーサ	1
7	23730	Switch Plate	スイッチ板	1
8	5587	Screw for 23730	スイッチ板止ネジ	1
9	23778	Presser Foot Lifter Lever	押エ掲ゲレバー	1
10	5512	Guide Screw for 23730	スイッチ板ガイドネジ	1
11	21547	Magnet Holding Ring Unit	マグネット取付台(組)	1
12	7609	Screw for 21547	マグネット取付台(組)止ネジ	2
13	9209	Screw for 21547	マグネット取付台(組)止ネジ	1
14	11933	IC, Complete Set (DN834)	ホールIC(組)(DN834)	1
15	5506	Screw for 11933	ホールIC(組)止ネジ	1
16	21539	IC Unit Supporting Plate	IC装置取付板支工	1
17	11709	Control Box Stay	コントロールボックスステイ	4
18	6910	Screw for 11709, 92232	止ネジ	10
19	11180	Control Box, Complete Set	制御装置(組)	1
20	11182	Control Board	CH制御基板	1
21	11974	Voltage Regulator	定電圧IC	1
22	11183	Power Board	CH電源基板	1
23	11192	Knee Switch, Complete Set	膝スイッチ(組)	1
24	92232	Knee Switch Holder	膝スイッチ取付板	1
25	11189	Knee Switch	膝スイッチ	1
26	538	Washer for 11189	ワッシャ	4
27	644	Spring Washer for 11189	スプリングワッシャ	2
28	23	Nut for 11189	ナット	2
29-1	11943	Power Cord (for 100 Voltage)	電源コード(100V用)	1
29-2	11944	“ (“ 200 “)	“ (200 “)	1
29-3	11945	“ (“ 220 “)	“ (220 “)	1
29-4	11946	“ (“ 380 “)	“ (380 “)	1
30	24254	Presser Foot Lifter Lever Connecting Link	押エ掲ゲレバーリンク	1
31-1	23770	Presser Foot, Complete Set (03)	押エ(組)(03)	1
31-2	23771	“ “ (04)	“ (04)	1
31-3	23772	“ “ (05)	“ (05)	1
32	21938	Presser Foot Hinge	押エヒンジ	1
33	4351	Screw for 21938	押エヒンジ止ネジ	1
34	23749	Presser Foot (Lower)	押エ(下)	1
35-1	23759	Presser Foot Stitch Tongue (03)	爪(03)	1
35-2	23748	“ “ (04)	“ (04)	1
35-3	23765	“ “ (05)	“ (05)	1
36	21005	Presser Foot Hinge Spring	押エヒンジバネ	1
37	4131	Screw for 21005	押エヒンジバネ止ネジ	1

"BT13" DEVICE (1)

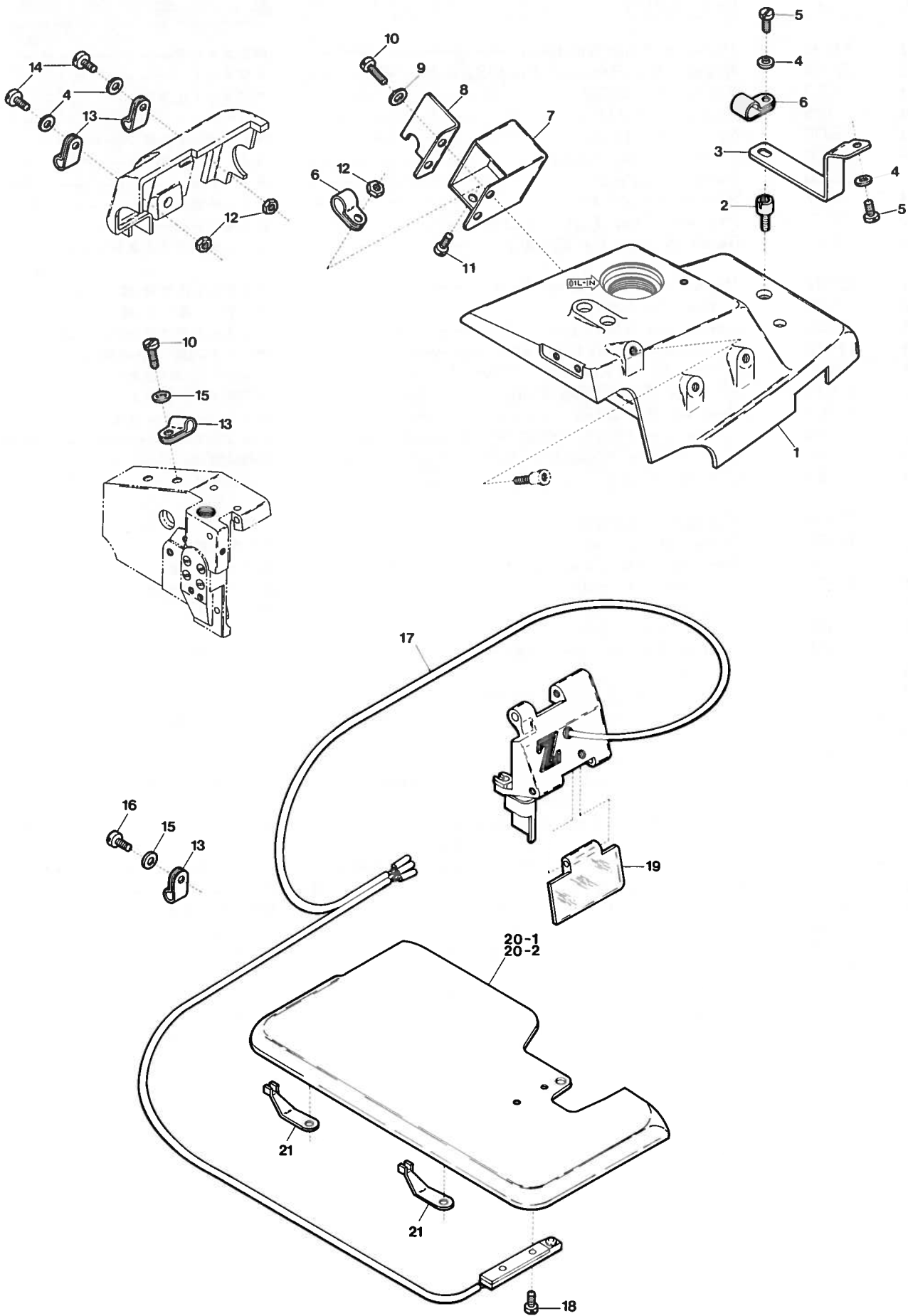

Ref. No.	Parts No.	Description	品名	Amt. Req.
1	24303	Top Cover	上カバー	1
2	4132	Screw for 24303	上カバー止ネジ	1
3	23191	Solenoid Stay	ソレノイドステイ	1
4	532	Washer for 23191, 94491	ワッシャ	4
5	4358	Screw for 23191	ソレノイドステイ止ネジ	2
6	36133	Cord Clamp (φ 8.4)	コードクランプ	2
7	11840	Connector Case	コネクタケース	1
8	11841	Connector Case Lid	コネクタケース蓋	1
9	550	Washer for 11841	ワッシャ	2
10	4440	Screw for 11841, 94491	止ネジ	3
11	4352	Screw for 36133	コードクランプ止ネジ	1
12	335	Nut for 36133, 94491	ナット	3
13	94491	Cord Clamp (φ 3.4)	コードクランプ	4
14	1175	Screw for 94491	コードクランプ止ネジ	2
15	542	Washer for 94491	ワッシャ	2
16	9853	Screw for 94491	コードクランプ止ネジ	1
17	11888	Photoelectric Switch, Complete Set	光電スイッチ(組)	1
18	4404	Screw for 11888	光電スイッチ(組)止ネジ	2
19	23175	Safety Plate	アイガード	1
20-1	23197	Cloth Plate (Z5003-O4)	クロスプレート	1
20-2	23205	“ “ (Z5020-X4)	“ “	1
21	24301	Cord Stay (Small)	コード支エ(小)	2

"BT13" DEVICE (2)

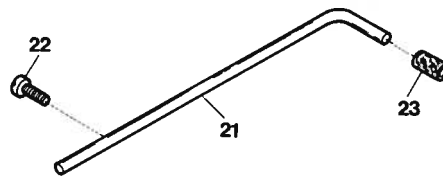
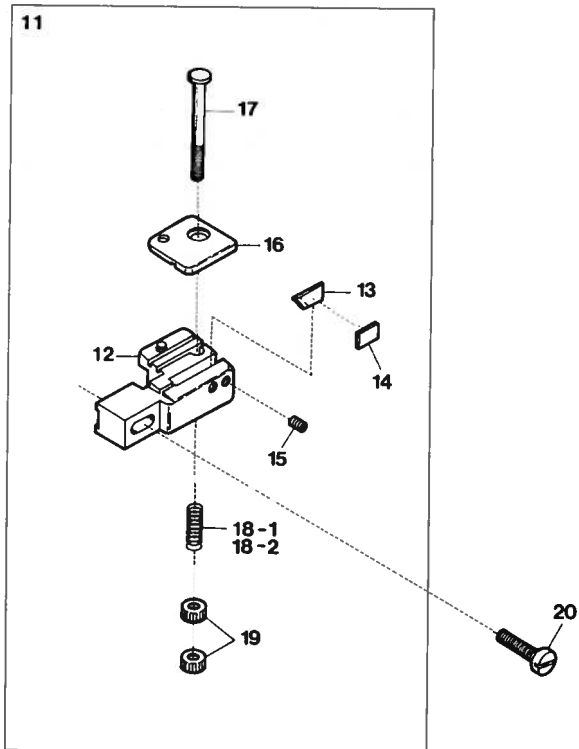
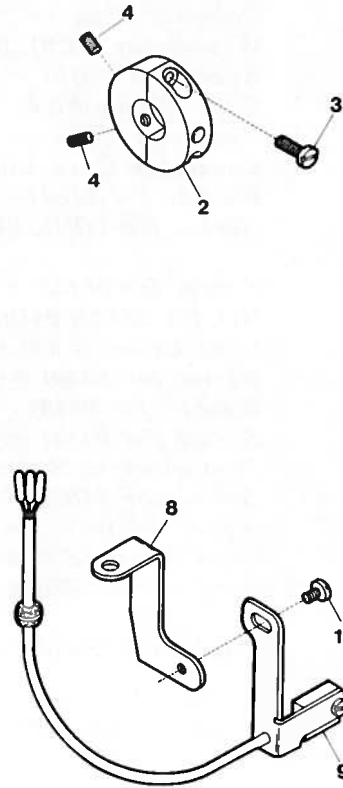
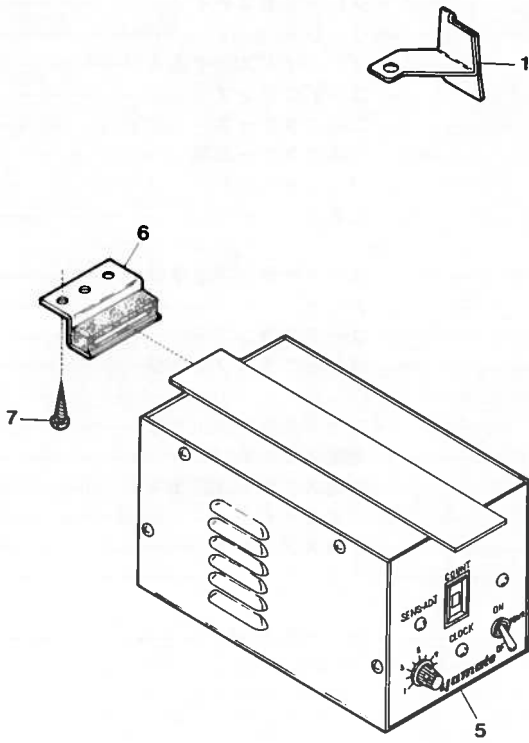

Ref. No.	Parts No.	Description	品名	Amt. Req.
1	22635	Lower Looper Cover	下ルーバカバー	1
2	23179	Magnet Holding Ring Unit	マグネット(組)	1
3	7609	Screw for 23179	マグネット(組)止ネジ	2
4	9209	Screw for 23179	マグネット(組)止ネジ	1
5	11848	Control Box, Complete Set	制御装置(組)	1
6	11709	Control Box Stay	コントロールボックスステイ	2
7	6910	Screw for 11709	コントロールボックスステイ止ネジ	4
8	21539	IC Unit Supporting Plate	IC装置取付板支工	1
9	11880	IC Unit (DN834)	ホールIC(組)	1
10	5506	Screw for 11880	ホールIC(組)止ネジ	1
11	23180	Back Tack Cutting Unit	空糸切り装置(組)	1
12	23203	Chain-off Cutting Knife Holder	刃取付台	1
13	23184	Chain-off Cutting Knife	刃	1
14	23169	Chain-off Cutting Knife Holder Spacer	刃取付台スペーサ	1
15	3637	Screw for 23184	刃止ネジ	2
16	23181	Chain-off Holder	空糸押工	1
17	4205	Screw for 23181	空糸押工止ネジ	1
18-1	23182	Chain-off Holder Spring (Standard)	空糸押工バネ(標準)	1
18-2	33711	“ “ (With Stronger Pressure)	“ “ (バネ圧強い)	1
19	361	Adjusting Nut for 23182	空糸押工バネ調節ナット	2
20	1923	Screw for 23203	刃取付台止ネジ	1
21	22836	Synchronizer Positioning Pin	ポジションナピン	1
22	9508	Screw for 22836	ポジションナピン止ネジ	1
23	22837	Synchronizer Cushion	ポジションナピンクッション	1

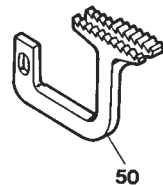
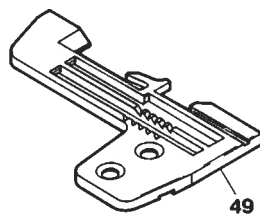
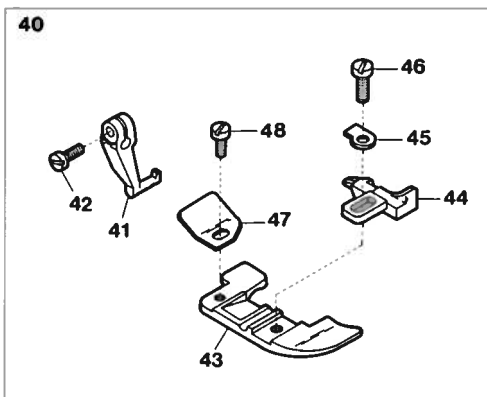
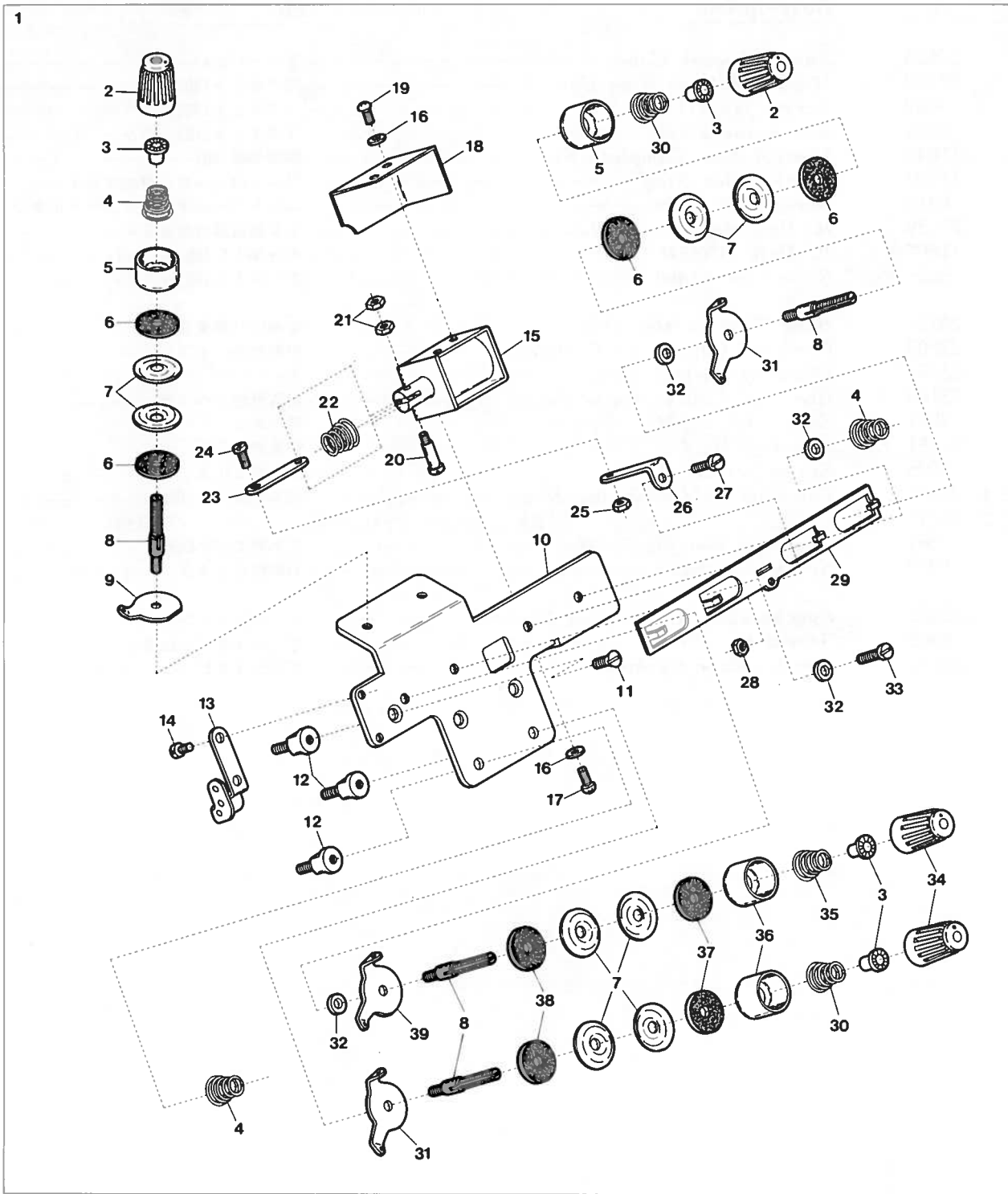

Ref. No.	Parts No.	Description	品名	Amt. Req.
1	23198	Thread Tension Release, Complete Set	糸緩メ装置(組)	1
2	33806	Thread Tension Spring Cap	糸調子バネキャップ(上)	3
3	33890	Tension Spring Bushing	糸調子ナット回り止メ	6
4	20103	Thread Tension Spring	糸調子バネ	3
5	33807	Thread Tension Spring Retainer	糸調子バネキャップ(下)	3
6	286	Felt for 31111	フェルト	6
7	31111	Tension Disc	糸調子皿	12
8	7904	Tension Post	糸調子棒	6
9	36853	Tension Disc Eyelet	調子台糸道	1
10	23185	Thread Tension Release Supporting Board	糸緩メ台	1
11	1396	Screw for 23185	糸緩メ台止ネジ	3
12	4151	Screw for 23185	糸緩メ台取付ケネジ	3
13	23188	Tension Disc Auxiliary Eyelet	調子台補助糸道	1
14	4358	Screw for 23188	調子台補助糸道止ネジ	2
15	11839	Thread Tension Release Solenoid	ソレノイド	1
16	14	Washer for 11839, 23189	ワッシャ	4
17	9994	Screw for 11839	ソレノイド止ネジ	2
18	23189	Solenoid Cover	ソレノイドカバー	1
19	9995	Screw for 23189	ソレノイドカバー止ネジ	2
20	5128	Solenoid Connecting Pin	ソレノイド連結ピン	1
21	21	Nut for 5128	ナット	2
22	32971	Solenoid Spring	ソレノイドバネ	1
23	23187	Thread Tension Release Link	糸緩メリンク	1
24	6092	Screw for 23187	糸緩メリンク止ネジ	1
25	330	Nut for 23187	ナット	1
26	23186	Thread Tension Release Plate Guide	糸緩メ板ガイド	1
27	4312	Screw for 23186	糸緩メ板ガイド止ネジ	1
28	331	Nut for 23186	ナット	1
29	23190	Thread Tension Release Plate	糸緩メ板	1
30	20102	Thread Tension Spring	糸調子バネ	3
31	20101	Tension Disc Eyelet	調子台糸道	4
32	496	Spacer for 20101, 21001	スペーサ	4
33	9843	Screw for 496	スペーサ止ネジ	1
34	20104	Thread Tension Spring Cap	糸調子バネキャップ(上)	3
35	20132	Thread Tension Spring	糸調子バネ	1
36	20118	Thread Tension Spring Retainer	糸調子バネキャップ(下)	3
37	178	Felt for 31111	フェルト	3
38	177	Felt for 31111	フェルト	3
39	21001	Tension Disc Eyelet	調子台糸道	1
40	23209	Presser Foot, Complete Set (O4)	押工(組)(O4)	1
41	21938	Presser Foot Hinge	押工ヒンジ	1
42	4351	Screw for 21938	押工ヒンジ止ネジ	1
43	21967	Presser Foot (Lower)	押工(下)	1
44	23208	Presser Foot Stitch Tongue	爪	1
45	21005	Presser Foot Hinge Spring	押工ヒンジバネ	1
46	4131	Screw for 21005	押工ヒンジバネ止ネジ	1
47	34535	Presser Foot Chain Shield	空糸押工	1
48	1228	Screw for 34535	空糸押工止ネジ	1
49	22669	Stitch Plate (O4)	針板(O4)	1
50	22376	Differential Feed Dog	前送り	1
51	22377	Main Feed Dog	後送り	1

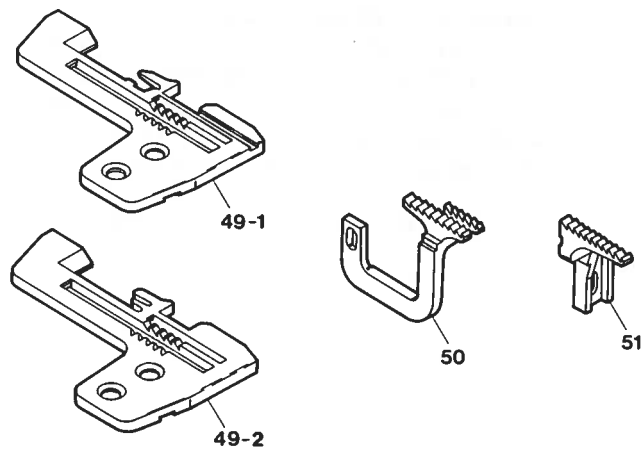
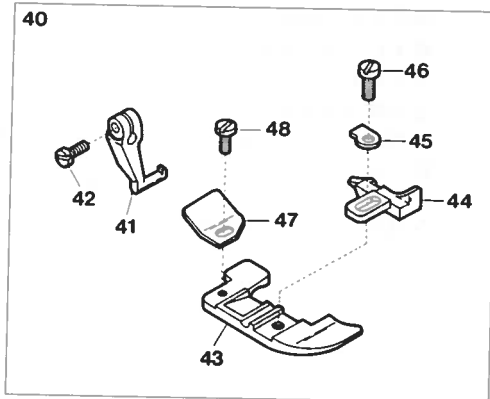
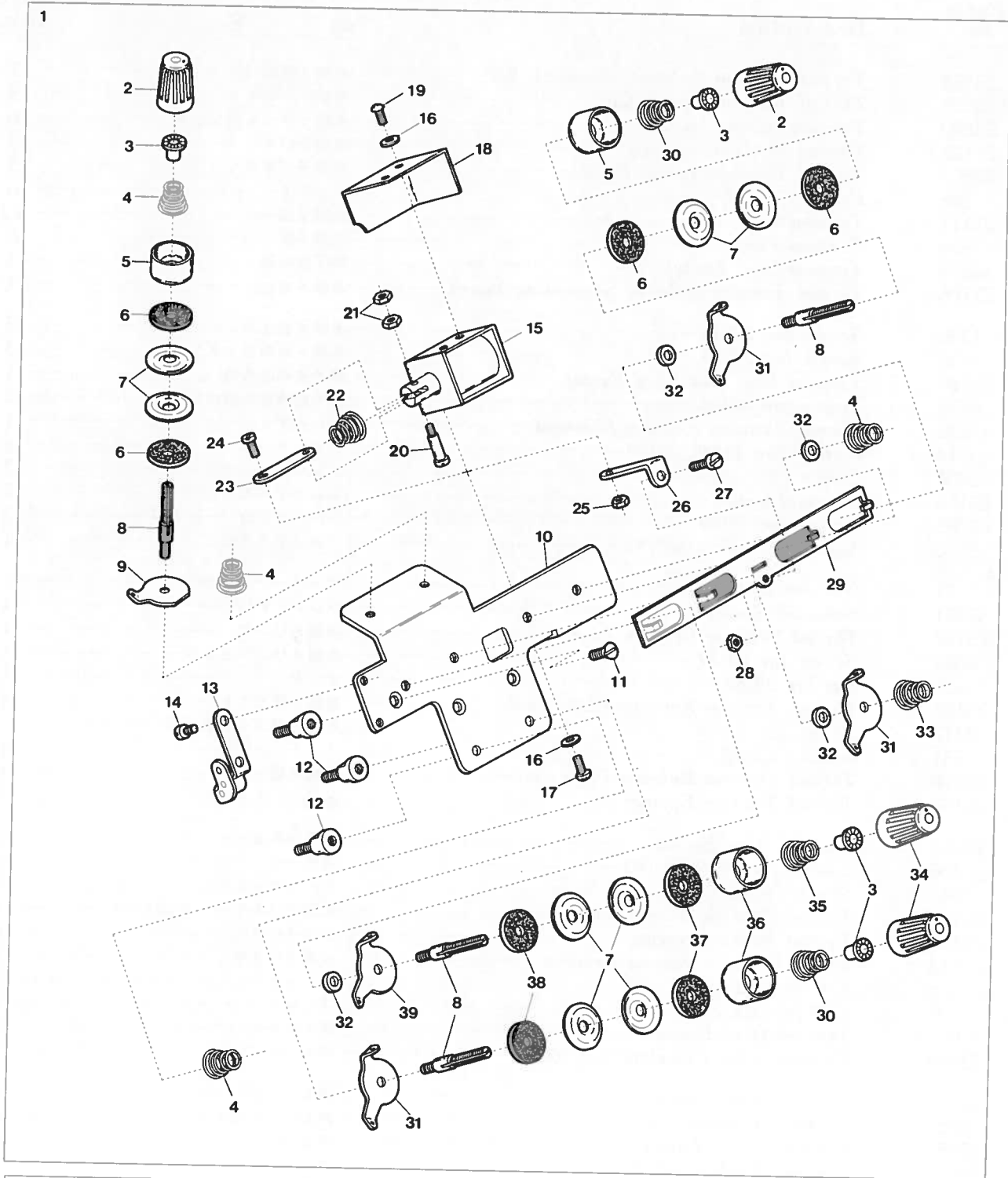

Ref. No.	Parts No.	Description	品 名	Amt. Req.
1	23192	Thread Tension Release, Complete Set	糸緩メ装置(組)	1
2	33806	Thread Tension Spring Cap	糸調子バネキャップ(上)	4
3	33890	Tension Spring Bushing	糸調子ナット回り止メ	8
4	20103	Thread Tension Spring	糸調子バネ	4
5	33807	Thread Tension Spring Retainer	糸調子バネキャップ(下)	4
6	286	Felt for 31111	フェルト	8
7	31111	Tension Disc	糸調子皿	16
8	7904	Tension Post	糸調子棒	8
9	36853	Tension Disc Eyelet	調子台糸道	2
10	23185	Thread Tension Release Supporting Board	糸緩メ台	1
11	1396	Screw for 23185	糸緩メ台止ネジ	3
12	4151	Screw for 23185	糸緩メ台取付ケネジ	3
13	23188	Tension Disc Auxiliary Eyelet	調子台補助糸道	1
14	4358	Screw for 23188	調子台補助糸道止ネジ	2
15	11839	Thread Tension Release Solenoid	ソレノイド	1
16	14	Washer for 11839, 23189	ワッシャ	4
17	9994	Screw for 11839	ソレノイド止ネジ	2
18	23189	Solenoid Cover	ソレノイドカバー	1
19	9995	Screw for 23189	ソレノイドカバー止ネジ	2
20	5128	Solenoid Connecting Pin	ソレノイド連結ピン	1
21	21	Nut for 5128	ナット	2
22	32971	Solenoid Spring	ソレノイドバネ	1
23	23187	Thread Tension Release Link	糸緩メリンク	1
24	6092	Screw for 23187	糸緩メリンク止ネジ	1
25	330	Nut for 23187	ナット	1
26	23186	Thread Tension Release Plate Guide	糸緩メ板ガイド	1
27	4312	Screw for 23186	糸緩メ板ガイド止ネジ	1
28	331	Nut for 23186	ナット	1
29	23190	Thread Tension Release Plate	糸緩メ板	1
30	20102	Thread Tension Spring	糸調子バネ	2
31	20101	Tension Disc Eyelet	調子台糸道	5
32	496	Spacer for 20101, 21001	スペーサ	4
33	20132	Thread Tension Spring	糸調子バネ	1
34	20104	Thread Tension Spring Cap	糸調子バネキャップ(上)	4
35	30255	Thread Tension Spring	糸調子バネ	1
36	20118	Thread Tension Spring Retainer	糸調子バネキャップ(下)	4
37	178	Felt for 31111	フェルト	4
38	177	Felt for 31111	フェルト	4
39	21001	Tension Disc Eyelet	調子台糸道	1
40	23174	Presser Foot, Complete Set (X4)	押工(組)(X4)	1
41	21938	Presser Foot Hinge	押工ヒンジ	1
42	4351	Screw for 21938	押工ヒンジ止ネジ	1
43	22667	Presser Foot (Lower)	押工(下)	1
44	23173	Presser Foot Stitch Tongue	爪	1
45	21005	Presser Foot Hinge Spring	押工ヒンジバネ	1
46	4131	Screw for 21005	押工ヒンジバネ止ネジ	1
47	34535	Presser Foot Chain Shield	空糸押工	1
48	1228	Screw for 34535	空糸押工止ネジ	1
49-1	23172	Stitch Plate (X4)	針板(X4)	1
49-2	23223	" " (for Cover Seaming) (EXTRA)	" (地縫用)(特注品)	1
50	23170	Differential Feed Dog	前送り	1
51	23171	Main Feed Dog	後送り	1

"B3"DEVICE

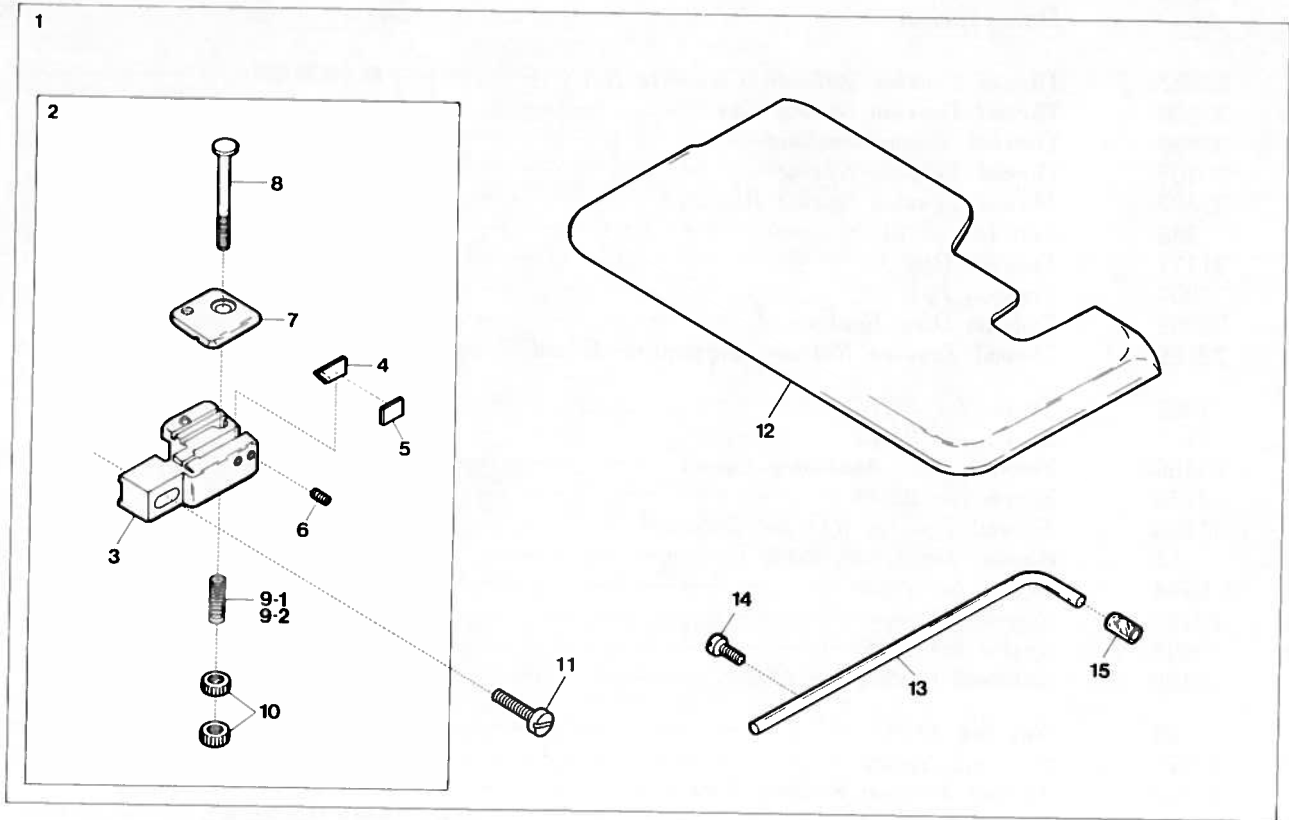

Z5003-03-2/B3

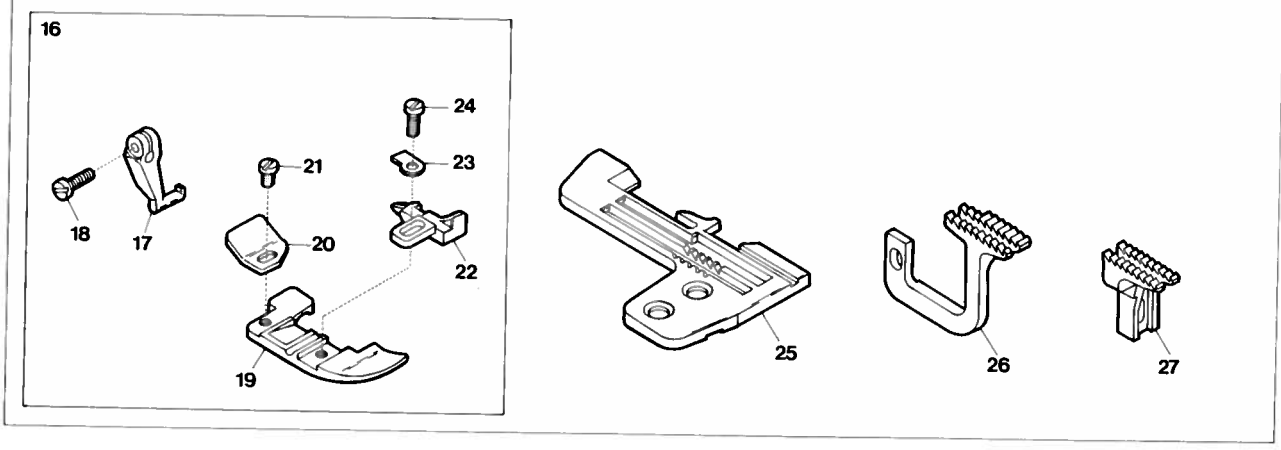

Ref. No.	Parts No.	Description	品名	Amt. Req.
1	23206	"B3" Device, Complete Set	"B3"装置(組)	1
2	23180	Back Tuck Cutting Unit	空糸切り装置	1
3	23203	Chain-off Cutting Knife Holder	刃取付台	1
4	23184	Chain-off Cutting Knife	刃	1
5	23169	Chain-off Cutting Knife Holder Spacer	刃取付台スペーサ	1
6	3637	Screw for 23184	刃止ネジ	2
7	23181	Chain-off Holder	空糸押工	1
8	4205	Screw for 23181	空糸押工止ネジ	1
9-1	23182	Chain-off Holder Spring (Standard)	空糸押工バネ(標準)	1
9-2	33711	" " " (With Stronger Pressure)	" (バネ圧強い)	1
10	361	Adjusting Nut for 23182	空糸押工バネ調節ナット	2
11	1923	Screw for 23203	刃取付台止ネジ	1
12	23201	Cloth Plate	クロスプレート	1
13	22836	Synchronizer Positioning Pin	ポジションナビン	1
14	9508	Screw for 22836	ポジションナビン止ネジ	1
15	22837	Synchronizer Cushion	ポジションナビンクッション	1
16	23212	Presser Foot, Complete Set (03)	押工(組)(03)	1
17	21938	Presser Foot Hinge	押工ヒンジ	1
18	4351	Screw for 21938	押工ヒンジ止ネジ	1
19	21967	Presser Foot (Lower)	押工(下)	1
20	34535	Presser Foot Chain Shield	空糸押工	1
21	1228	Screw for 34535	空糸押工止ネジ	1
22	23211	Presser Foot Stitch Tongue	爪	1
23	21005	Presser Foot Hinge Spring	押工ヒンジバネ	1
24	4131	Screw for 21005	押工ヒンジバネ止ネジ	1
25	22375	Stitch Plate	針板	1
26	22376	Differential Feed Dog	前送り	1
27	22377	Main Feed Dog	後送り	1

EXTRA PARTS(1)

UNCURLER DEVICE

- 1-1
- 1-2
- 1-3
- 1-4
- 1-5
- 1-6
- 1-7
- 1-8

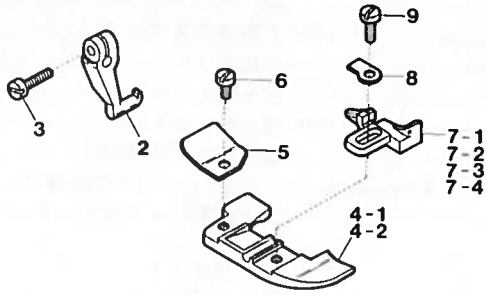

- 10-1
- 10-2
- 10-3

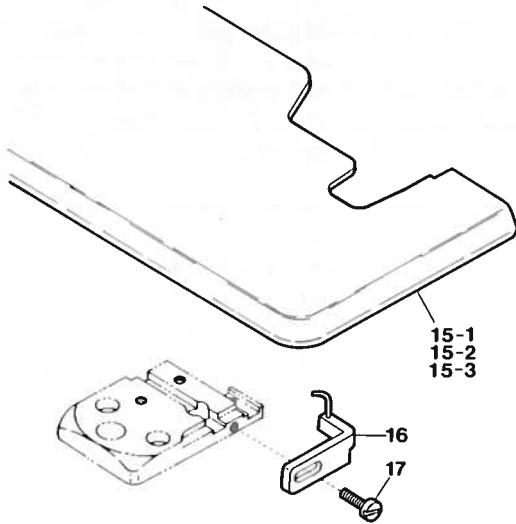
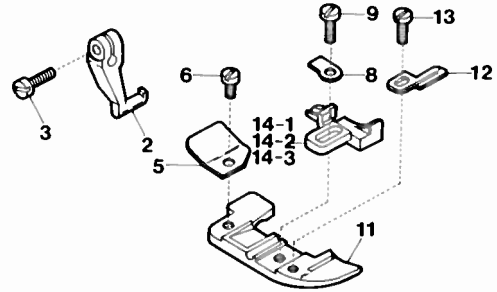

18

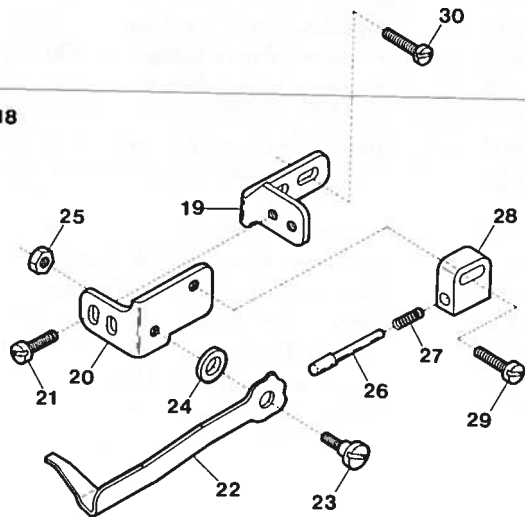

31

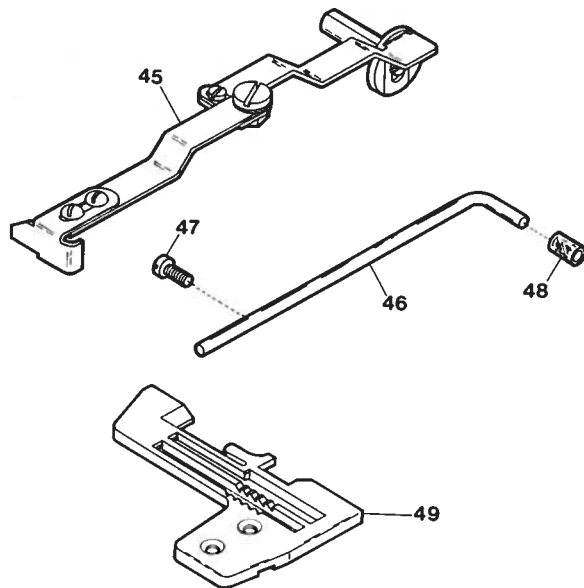
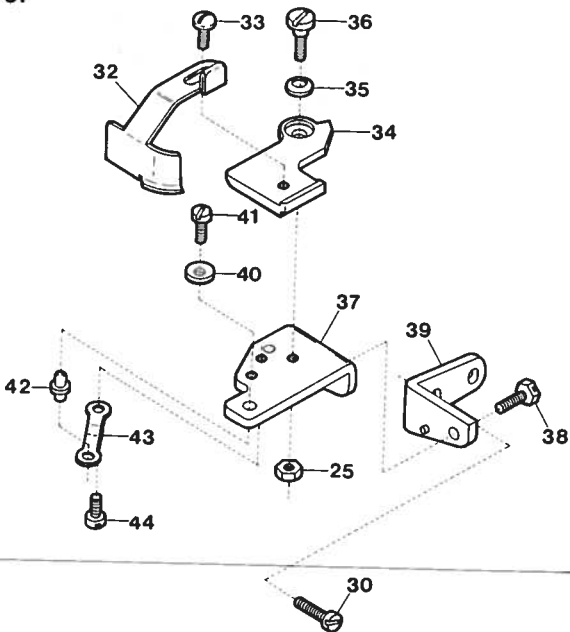

Ref. No.	Parts No.	Description	品名	Amt. Req.
1-1	22856	Presser Foot, Complete Set (Z5003-O4)	押エ(組)(カール防止用)	1
1-2	22857	" " " " (Z5003-O4/K2)	" "	1
1-3	22858	" " " " (Z5020-X4)	" "	1
1-4	22859	" " " " (Z5020-Y5)	" "	1
1-5	22860	" " " " (Z5020-Y6)	" "	1
1-6	22864	" " " " (Z5020-X4/K2)	" "	1
1-7	22865	" " " " (Z5020-Y5/K2)	" "	1
1-8	22866	" " " " (Z5020-Y6/K2)	" "	1
2	21938	Presser Foot Hinge	押エヒンジ	1
3	4351	Screw for 21938	押エヒンジ止ネジ	1
4-1	22861	Presser Foot (Lower)	押エ(下)	1
4-2	22862	" " " (for K2 Device)	" (K2装置用)	1
5-1	34535	Presser Foot Chain Shield	空糸押エ	1
5-2	33471	" " " " (for K2 Device)	" (K2装置用)	1
6	1228	Screw for 34535, 33471	空糸押エ止ネジ	1
7-1	21872	Presser Foot Stitch Tongue (O4)	爪	1
7-2	21870	" " " " (X4)	"	1
7-3	21864	" " " " (Y5)	"	1
7-4	21865	" " " " (Y6)	"	1
8	21005	Presser Foot Hinge Spring	押エヒンジバネ	1
9	4131	Screw for 21005	押エヒンジバネ止ネジ	1
10-1	22867	Presser Foot, Complete Set (Z5025-X4)	押エ(組)(カール防止用)	1
10-2	22868	" " " " (Z5025-Y5)	" "	1
10-3	22869	" " " " (Z5025-Y6)	" "	1
11	22863	Presser Foot (Lower)	押エ(下)	1
12	21165	Presser Foot Tape Guide	押エテープガイド	1
13	1230	Screw for 21165	押エテープガイド止ネジ	1
14-1	22605	Presser Foot Stitch Tongue (X4)	爪	1
14-2	21866	" " " " (Y5)	"	1
14-3	21867	" " " " (Y6)	"	1
15-1	22880	Cloth Plate	クロスプレート	1
15-2	22881	" " (for K2 Device)	" (K2装置用)	1
15-3	22883	" " (for MT Device)	" (MT装置用)	1
16	22426	Uncurler (for downward curling) Unit	下カール防止定規(組)	1
17	1175	Screw for 22426	下カール防止定規(組)止ネジ	1
18	22420	Uncurler (for upward curling), Complete Set	上カール防止定規(組)	1
19	22425	Uncurler Holder Support	上カール防止定規取付台	1
20	22424	Uncurler Holder	上カール防止定規取付板	1
21	4358	Screw for 22424	上カール防止定規取付板止ネジ	2
22	22421	Uncurler (for upward curling)	上カール防止定規	1
23	4100	Screw for 22421	上カール防止定規止ネジ	1
24	500	Washer for 22421	ワッシャ	1
25	334	Nut for 22421, 22431	ナット	2
26	22423	Uncurler Stopper	定規ストップバ	1
27	80504	Uncurler Stopper Spring	定規ストップババネ	1
28	22422	Uncurler Stopper Holder	定規ストップバ取付台	1
29	7405	Screw for 22422	定規ストップバ取付台止ネジ	1
30	4440	Screw for 22425, 22433	止ネジ	4

※ Ref. No. 31 to 49..... See the following page.

EXTRA PARTS (1)

UNCURLER DEVICE

- 1-1
- 1-2
- 1-3
- 1-4
- 1-5
- 1-6
- 1-7
- 1-8

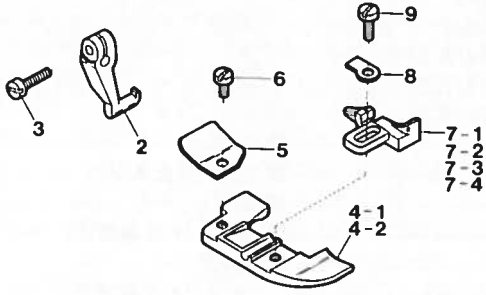

- 10-1
- 10-2
- 10-3

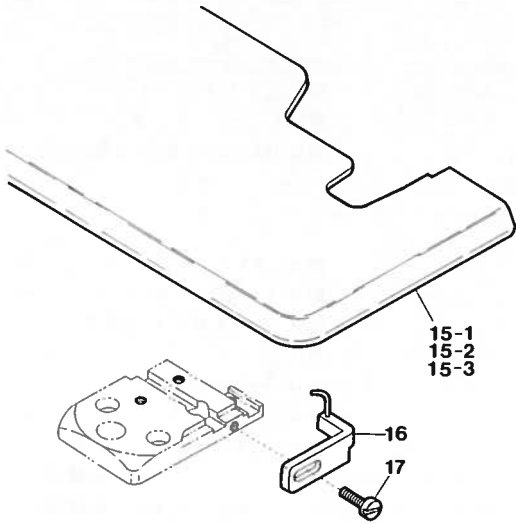
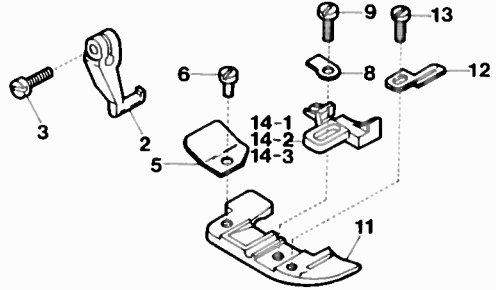

- 18

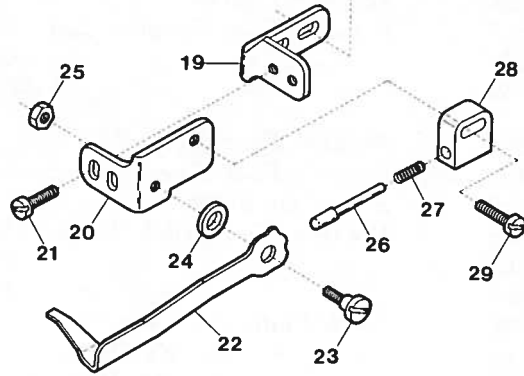

- 31

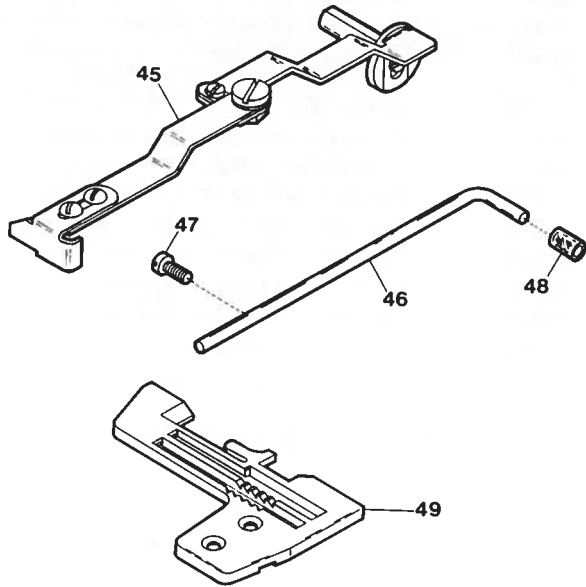
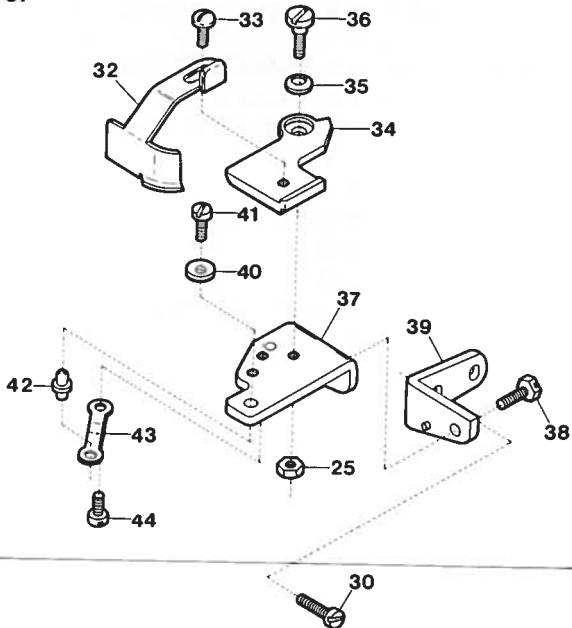

※ Ref. No. 1 to 30.....See the preceding page.

Ref. No.	Parts No.	Description	品 名	Amt. Req.
31	22430	Edge Guide, Complete Set	当て定規(組)	1
32	22432	Edge Guide	当て定規	1
33	1330	Screw for 22432	当て定規止ネジ	1
34	22431	Edge Guide Swing-out Lever	スイングアウトレバー	1
35	172	Spring Washer for 22431	スプリングワッシャ	1
36	4150	Screw for 22431	スイングアウトレバー止ネジ	1
37	22434	Edge Guide Swing-out Lever Holder	スイングアウトレバー取付台	1
38	5506	Screw for 22434	スイングアウトレバー取付台止ネジ	1
39	22433	Edge Guide Swing-out Lever Holder Support	定規取付台	1
40	22437	Edge Guide Swing-out Lever Stopper	スイングアウトレバーストッパ	1
41	7616	Screw for 22437	スイングアウトレバーストッパ止ネジ	1
42	22435	Edge Guide Positioning Pin	定規固定ピン	1
43	22436	Edge Guide Positioning Pin Holder Spring	定規固定ピン押エバネ	1
44	1227	Screw for 22436	定規固定ピン押エバネ止ネジ	1
45	20700	Edge Guide, Complete Set	当て定規(組)	1
46	22836	Synchronizer Positioning Pin	ポジションナピン	1
47	9508	Screw for 22836	ポジションナピン止ネジ	1
48	22837	Synchronizer Cushion	ポジションナピンクッション	1
49	22609	Stitch Plate (05)	針板(05)	1
(Only the width of tongue is different comparing with Z5003-04 Stitch Plate.)			(Z5003-04と爪幅のみ異なる)	

EXTRA PARTS (2)

テフロック押工 *Presser Foot (Tefron-processed Bottom)*

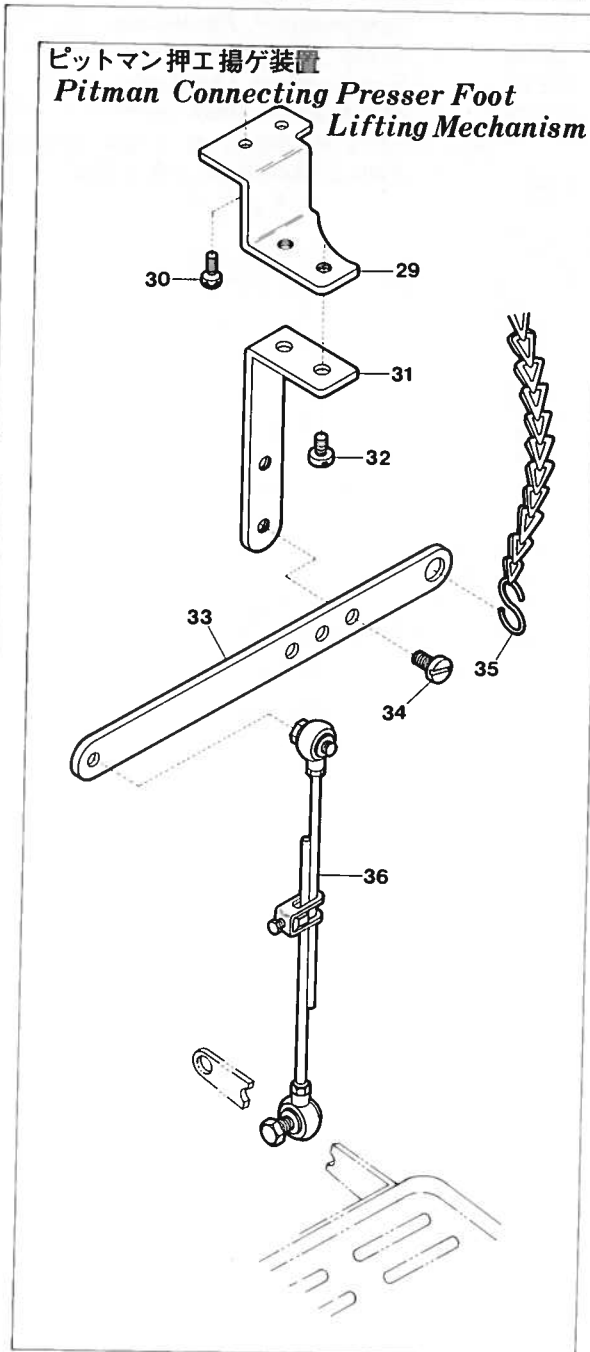
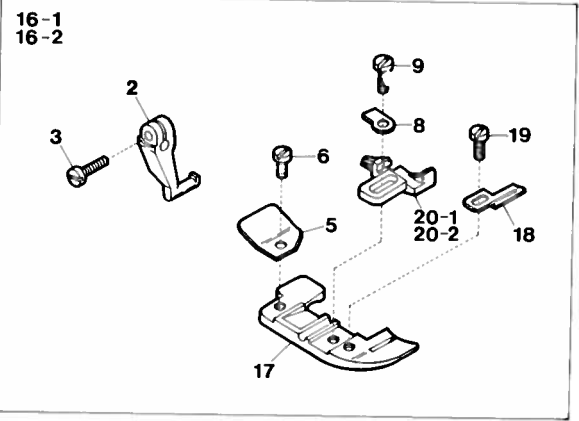
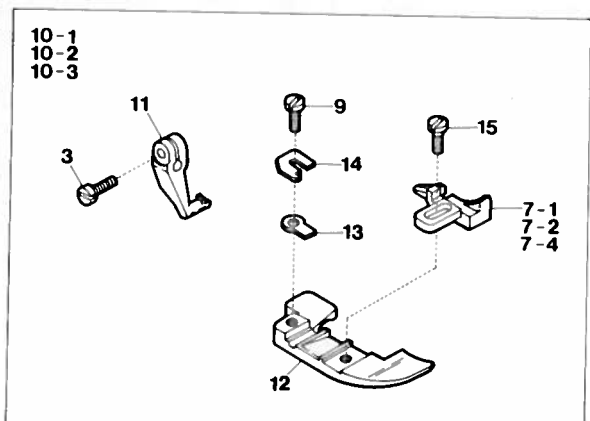
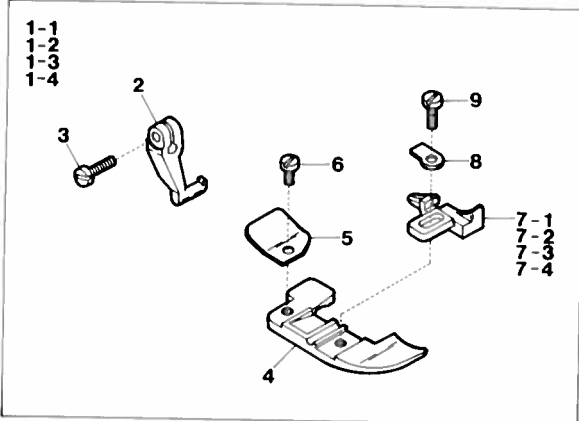

小回り押工
Presser Foot for Small turning

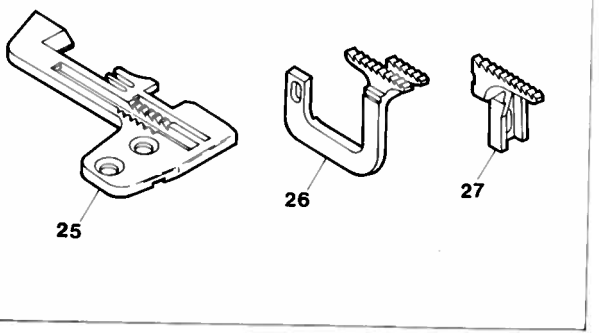
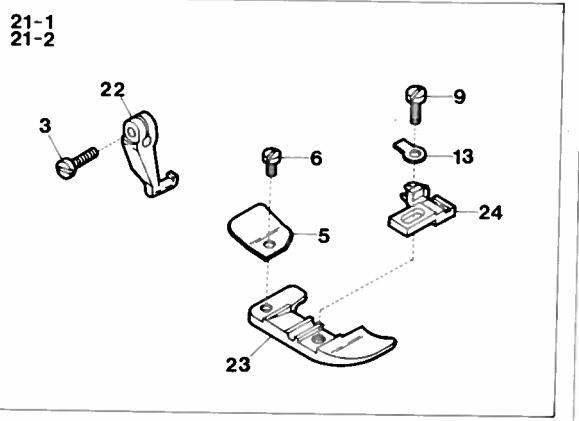

Ref. No.	Parts No.	Description	品名	Amt. Req.
1-1	22781	Presser Foot, Complete Set (Z5003-04)	押工(組)	1
1-2	22786	" " (Z5020-X4)	"	1
1-3	22784	" " (Z5020-Y5)	"	1
1-4	22785	" " (Z5020-Y6)	"	1
2	21938	Presser Foot Hinge	押エヒンジ	1
3	4351	Screw for 21938, 21242, 22016	押エヒンジ止ネジ	1
4	21982	Presser Foot (Lower)	押工(下)	1
5	34535	Presser Foot Chain Shield	空糸押工	1
6	1228	Screw for 34535	空糸押工止ネジ	1
7-1	21872	Presser Foot Stitch Tongue (04)	爪	1
7-2	21870	" " (X4)	"	1
7-3	21864	" " (Y5)	"	1
7-4	21865	" " (Y6)	"	1
8	21005	Presser Foot Hinge Spring	押エヒンジバネ	1
9	4131	Screw for 21005, 22519, 21243	止ネジ	1
10-1	22789	Presser Foot, Complete Set (Z5003-04-3)	押工(組)	1
10-2	22791	" " (Z5020-X4-3)	"	1
10-3	22790	" " (Z5020-Y6-3)	"	1
11	21242	Presser Foot Hinge	押エヒンジ	1
12	21984	Presser Foot (Lower)	押工(下)	1
13	21243	Presser Foot Hinge Spring	押エヒンジバネ	1
14	22519	Presser Foot Adjusting Plate	押工調節片	1
15	4138	Screw for Stitch Tongue	爪止ネジ	1
16-1	22787	Presser Foot, Complete Set (Z5025-Y5)	押工(組)	1
16-2	22788	" " (Z5025-Y6)	"	1
17	21983	Presser Foot (Lower)	押工(下)	1
18	21165	Presser Foot Tape Guide	押エテープガイド	1
19	1230	Screw for 21165	押エテープガイド止ネジ	1
20-1	21866	Presser Foot Stitch Tongue (Y5)	爪	1
20-2	21867	" " (Y6)	"	1
21	22021	Presser Foot, Complete Set (Z5020-Y6)	押工(組)	1
22	22016	Presser Foot Hinge	押エヒンジ	1
23	22015	Presser Foot (Lower)	押工(下)	1
24	22017	Presser Foot Stitch Tongue (Y6)	爪	1
25	22018	Stitch Plate (Y6)	針板	1
26	22019	Differential Feed Dog	前送り	1
27	22020	Main Feed Dog	後送り	1
28	22620	Pitman Connecting Presser Foot Lifting Mechanism	ピットマン押工揚ゲ装置	1
29	22621	Presser Foot Lifter Link Support Stay	押工揚ゲリンク取付板支工	1
30	9992	Screw for 22621	押工揚ゲリンク取付板支工止ネジ	2
31	36907	Presser Foot Lifter Link Support	押工揚ゲリンク取付板	1
32	5062	Screw for 36907	押工揚ゲリンク取付板止ネジ	2
33	36908	Presser Foot Lifter Link	押工揚ゲリンク	1
34	8076	Screw for 36908	押工揚ゲリンク止ネジ	1
35	37912	Chain	鎖	1
36	36909	Pitman Connecting Rod Unit	ピットマン(組)	1

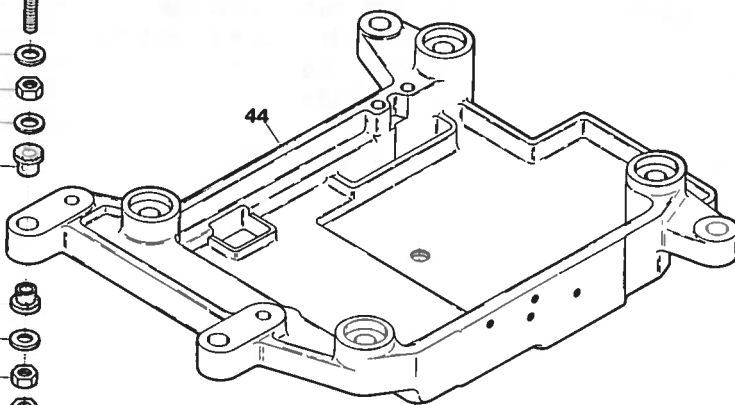
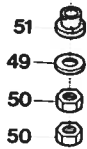
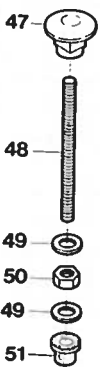
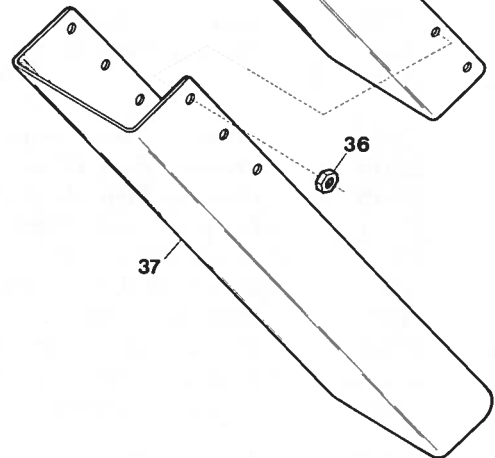
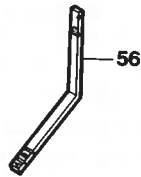
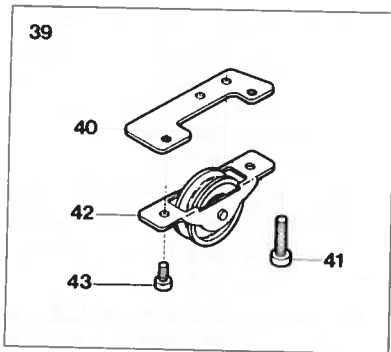
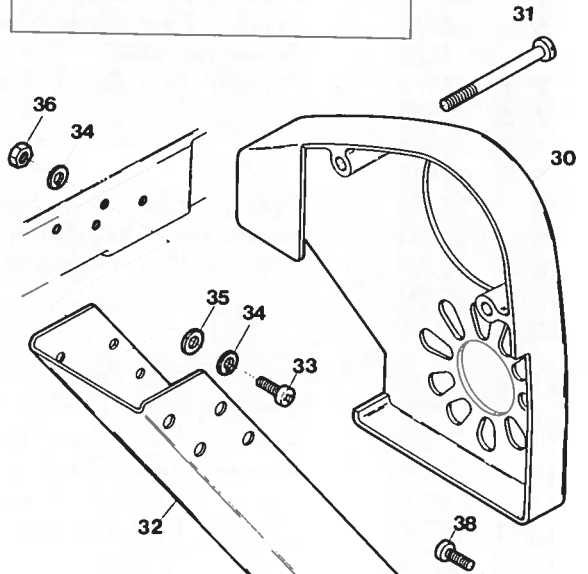
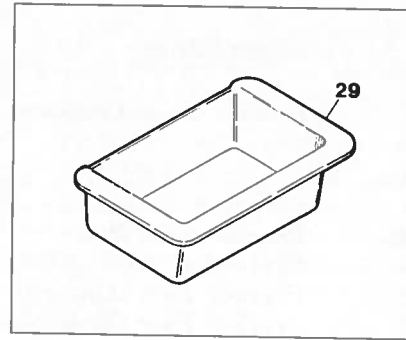
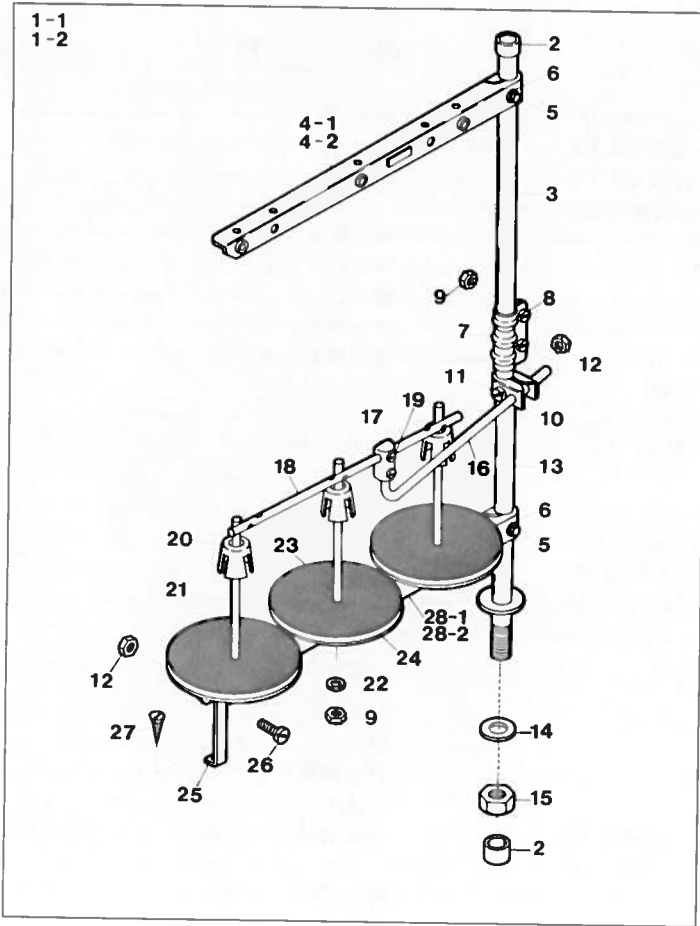

Full-Submerged Setting

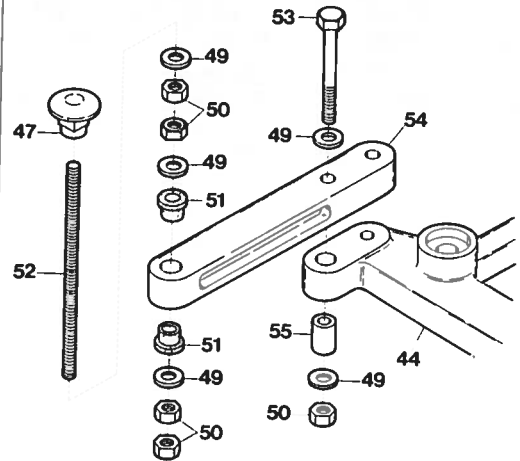

Ref. No.	Parts No.	Description	品名	Amt. Req.
1-1	99072	Thread Stand, Complete Set (3 Spools Type)	糸立台(組)(3本糸用)	1
1-2	99073	" " " " (4 Spools Type)	" (4本糸用)	1
2	99057	Column Cap	コラムキャップ	2
3	99058	Column Pipe (Upper)	コラムパイプ(上)	1
4-1	99060	Thread Hanger (3 Spools Type)	スレッドハンガ(3本糸用)	2
4-2	99059	" " (2 Spools Type)	" (2本糸用)	1
5	147	Screw for 99059, 99060	スレッドハンガ止ネジ	2
6	148	Washer for 99059, 99060	ワッシャ	2
7	99061	Column Pipe Connector	コラムパイプ継手	1
8	149	Screw for 99061	コラムパイプ継手止ネジ	2
9	150	Nut for 99061, 99066	ナット	5
10	99062	Thread Guide Holder	糸案内ホルダ	1
11	151	Screw for 99062	糸案内ホルダ止ネジ	1
12	152	Nut for 99062, 99069	ナット	2
13	99063	Column Pipe (Lower)	コラムパイプ(下)	1
14	154	Washer for 99063	ワッシャ	1
15	153	Nut for 99063	ナット	2
16	99030	Thread Guide Bar	糸案内支工棒	1
17	99031	Thread Guide Bar Bracket	支工棒接点	1
18	99064	Thread Guide	糸案内	1
19	156	Screw for 99064	糸案内止ネジ	2
20	99065	Spool Cushion	スプールクッション	3
21	99066	Spool Pin	スプール軸	3
22	157	Spring Washer for 99066	スプリングワッシャ	3
23	99067	Spool Mat	スプールマット	3
24	99068	Spool Seat Disc	受け皿	3
25	99069	Spool Holder Stay	スプールホルダ支工	1
26	158	Screw for 99069	スプールホルダ支工止ネジ	1
27	159	Wood Screw for 99069	木ネジ	1
28-1	99070	Spool Holder (3 Spools Type)	スプールホルダ(3本糸用)	1
28-2	99071	" " (2 Spools Type)	" (2本糸用)	2

※Ref. No. 29 to 56.....See the following page.

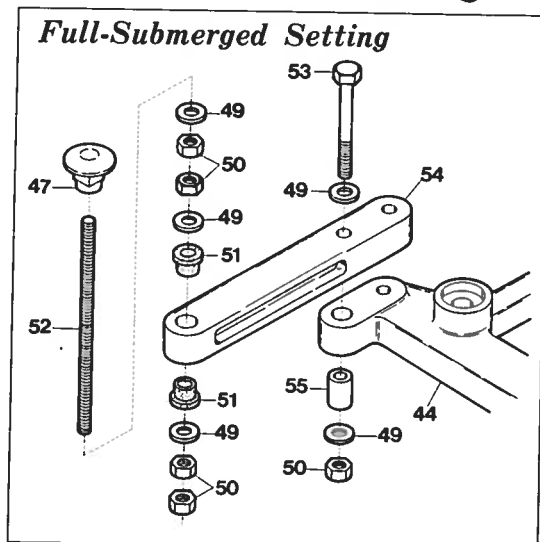
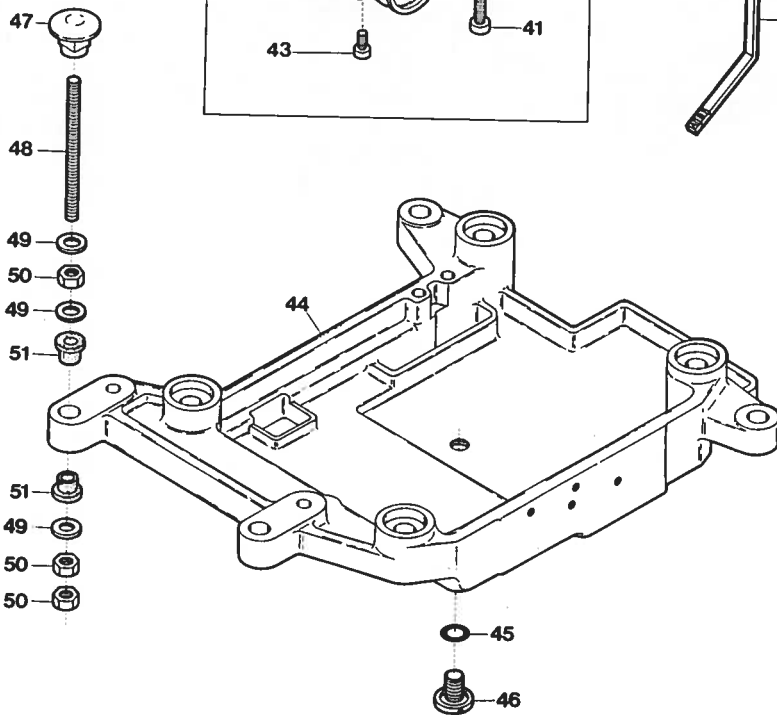
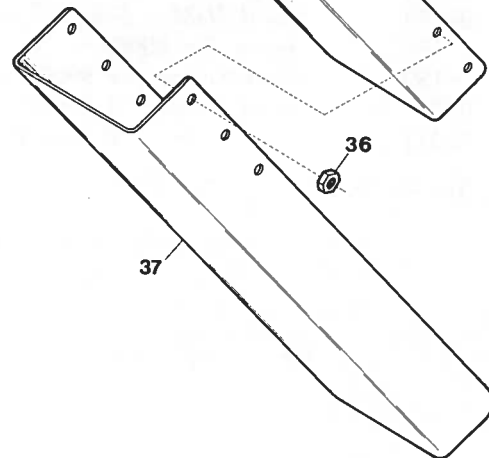
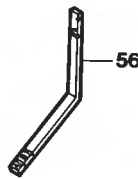
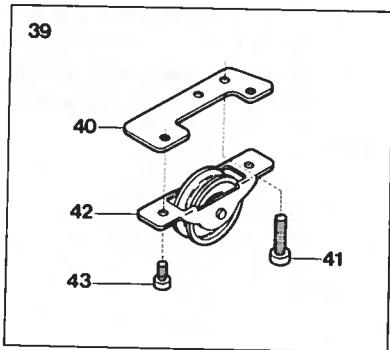
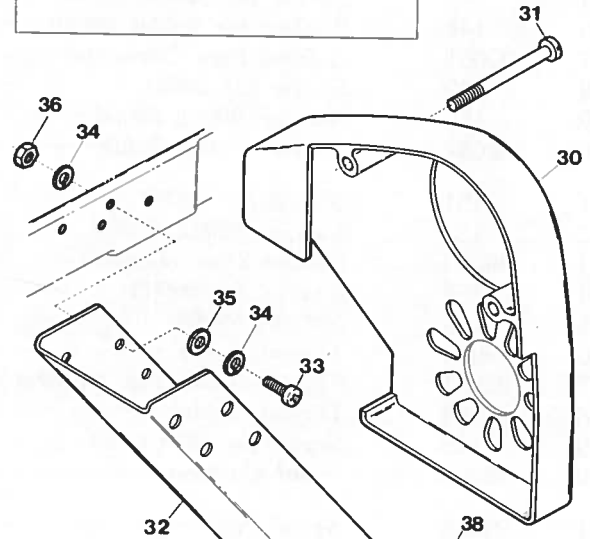
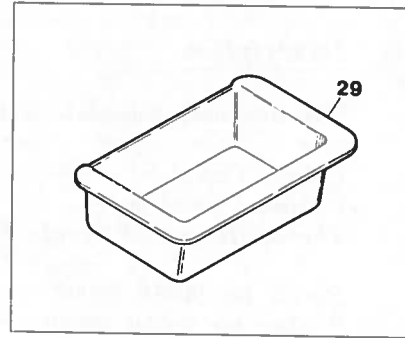
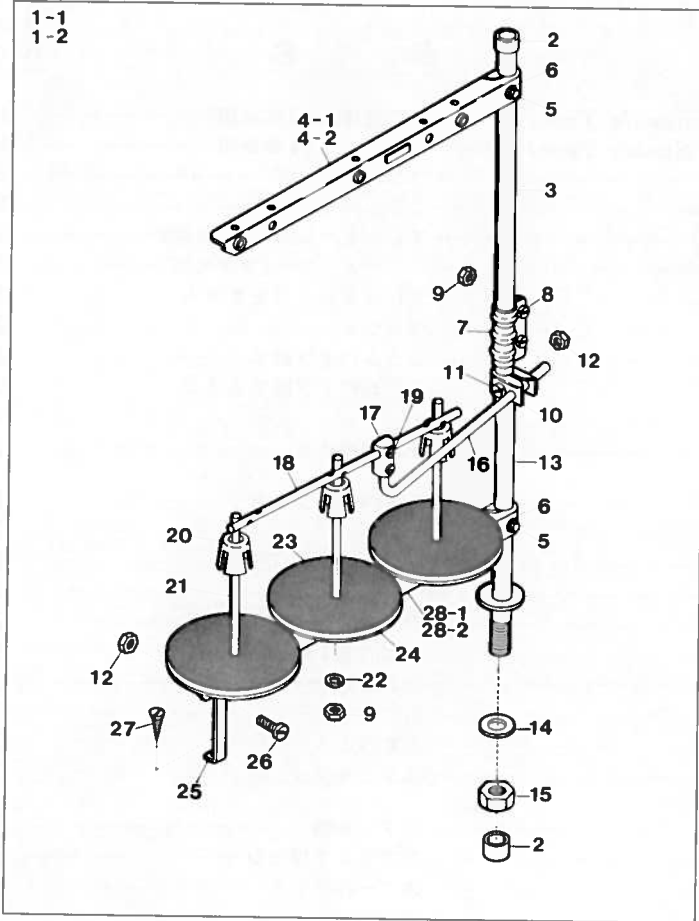

※Ref. No. 1 to 28-2 See the preceding page.

Ref. No.	Parts No.	Description	品 名	Amt. Req.
29	30080	Chip Receiver (Semi-submerged only)	切屑受ケ(半沈式のみ)	1
30	20039	Belt Cover	ベルトカバー	1
31	4102	Screw for 20039	ベルトカバー止ネジ	2
32	20068	Chute (Upper)	シュート(上)	1
33	9860	Screw for 20068	シュート(上)止ネジ	2
34	644	Spring Washer for 20068	スプリングワッシャ	4
35	665	Washer for 20068, 20069	ワッシャ	2
36	15	Nut for 20068, 20069	ナット	6
37	20069	Chute (Lower)	シュート(下)	1
38	4127	Screw for 20069	シュート(下)止ネジ	4
39	20078	Idler, Complete Set (for Left Footing Pedal)	アイドラ(組)	1
40	20077	Idler Support (for Left Footing Pedal)	アイドラ取付板	1
41	9992	Screw for 20077	アイドラ取付板止ネジ	2
42	20076	Idler (for Left Footing Pedal)	左足ペダル用アイドラ	1
43	9995	Screw for 20076	左足ペダル用アイドラ止ネジ	2
44	21328	Supporting Board	受ケ板	1
45	32421	Drain Hole Seal for Inner	リング	1
46	5076	Drain Hole Screw for Inner	受ケ板油抜キネジ(大)	1
47	160	Hanging Nut for 21328	吊リナット	4
48	164	Hanging Bolt for 21328 (Semi-submerged only)	吊リボルト(半沈式のみ)	4
49	162	Washer for 21328 (Semi-submerged)	ワッシャ(半沈式)	12
49	162	Washer for 21328 (Full-submerged)	ワッシャ(全沈式)	20
50	161	Nut for 21328 (Semi-submerged)	ナット(半沈式)	12
50	161	Nut for 21328 (Full-submerged)	ナット(全沈式)	20
51	20064	Supporting Board Rubber Cushion	受ケ板ゴム座	8
52	163	Hanging Bolt for 21328 (Full-submerged only)	吊リボルト(全沈式のみ)	4
53	165	Bolt for 20057 (Full-submerged only)	ボルト(全沈式のみ)	4
54	20057	Supporting Board Connector (Full-submerged only)	受ケ板支工具(全沈式のみ)	2
55	20045	Supporting Board Sleeve (Full-submerged only)	受ケ板スリーブ(全沈式のみ)	2
56	22589	Timing Gauge (Extra)	タイミングゲージ(特注品)	1

Z5000 Class List of Main Spare Parts (主要部品リスト) (1)

Main Parts Models	Needle Clamp	Presser Foot Complete Set	Presser Foot Hinge	Presser Foot (Lower)	Presser Foot Stitch Tongue	Stitch Plate
	針止メ	押エ(組)	押エヒンジ	押エ(下)	押エの爪	針板
Z5003-03	21002	23000	21938	21967	21871	21768
03/MT2	"	"	"	"	"	23441
03/MU4	"	23016	"	"	"	"
03/K2	"	23008	"	21972	"	21690
03-2	"	23024	"	21967	21884	21768
03-2/B3	"	23212	"	"	23211	22375
04	"	23001	"	"	21872	21769
04/MT2	"	"	"	"	"	22492
04/MU4	"	23018	"	"	"	"
04/K2	"	23010	"	21972	"	21691
04/BT13	"	23209	"	21967	23208	22669
04-3	"	22521	21242	21240	21872	21769
04-3/MT2	"	"	"	"	"	22492
04-3/K2	"	22529	"	22535	"	21691
05	"	23002	21938	21967	21873	21774
05/MT2	"	"	"	"	"	23442
05/MU4	"	23020	"	"	"	"
05/K2	"	23012	"	21972	"	21692
06	"	23003	"	21967	21874	21775
06/MT2	"	"	"	"	"	23443
06/MU4	"	23022	"	"	"	"
06/K2	"	23014	"	21972	"	21693
Z5000-03	"	21940	"	21939	21880	21759
03/K2	"	21947	"	21946	"	21686
03/CH20	"	23770	"	23749	23759	21759
03/CH20/K2	"	23773	"	23760	"	21686
04	"	21941	"	21939	21881	21761
04/MT2	"	"	"	"	"	22614
04/K2	"	21948	"	21946	"	21687
04/CH20	"	23771	"	23749	23748	21761
04/CH20/K2	"	23774	"	23760	"	21687
05	"	21942	"	21939	21882	21763
05/K2	"	21949	"	21946	"	21688
05/CH20	"	23772	"	23749	23765	21763
05/CH20/K2	"	23775	"	23760	"	21688
Z5006-02	"	23094	"	21196	21202	21197
Z5016-02	"	23082	"	21201	21218	21217

Note 1: In case of machines with KT2 and KR2 Devices, all component parts are not different from those for machines with K2 Device listed above.

(注1) KT2, KR2装置付の場合、部品は上記K2装置付と全く同じです。

Note 2: Indication of "DF" and "DA" have been omitted in the numbering on the above list.

(注2) 上記リストの全モデルの型式表示は"DF", "DA"の記号を省略しております。

Differential Feed Dog	Main Feed Dog	Auxiliary Feed Dog	Upper Looper	Lower Looper	Needle Guard (Front)	Needle Guard (Rear)
前送り	後送り	小送り	上ルーパ	下ルーパ	針受ケ(前)	針受ケ(後)
21846	21842	21009	21700	21701	20223	24169
〃	〃	22956	〃	〃	〃	〃
〃	〃	〃	〃	〃	〃	〃
〃	〃	21685	〃	〃	〃	〃
〃	〃	21009	〃	〃	〃	〃
22376	22377	〃	〃	〃	〃	〃
21846	21842	〃	〃	〃	〃	〃
〃	〃	22956	〃	〃	〃	〃
〃	〃	〃	〃	〃	〃	〃
〃	〃	21685	〃	〃	〃	〃
22376	22377	21009	〃	〃	〃	〃
21846	21842	〃	〃	〃	〃	〃
〃	〃	22956	〃	〃	〃	〃
〃	〃	21685	〃	〃	〃	〃
21847	〃	21009	〃	〃	〃	〃
〃	〃	22956	〃	〃	〃	〃
〃	〃	〃	〃	〃	〃	〃
〃	〃	21685	〃	〃	〃	〃
〃	〃	21009	〃	〃	〃	〃
〃	〃	22956	〃	〃	〃	〃
〃	〃	〃	〃	〃	〃	〃
〃	〃	21685	〃	〃	〃	〃
21840	21841	21009	〃	〃	〃	〃
〃	〃	21685	〃	〃	〃	〃
〃	〃	21009	〃	〃	〃	〃
〃	〃	21685	〃	〃	〃	〃
〃	〃	21009	〃	〃	〃	〃
〃	〃	〃	〃	〃	〃	〃
〃	〃	21685	〃	〃	〃	〃
〃	〃	21009	〃	〃	〃	〃
〃	〃	21685	〃	〃	〃	〃
〃	〃	21009	〃	〃	〃	〃
〃	〃	21685	〃	〃	〃	〃
〃	〃	21009	〃	〃	〃	〃
〃	〃	21685	〃	〃	〃	〃
21204	21205	21195	〃	〃	〃	〃
〃	〃	21220	〃	〃	〃	〃

Z5000 Class List of Main Spare Parts (主要部品リスト) (2)

Main Parts Models	Needle Clamp	Presser Foot Complete Set	Presser Foot Hinge	Presser Foot (Lower)	Stitch Tongue	Stitch Plate
	針止メ	押エ(組)	押エヒンジ	押エ(下)	押エの爪	針板
Z5020-X4	21893	23030	21938	21967	21870	21781
X4/MT2	"	"	"	"	"	22493
X4/MU4	"	23046	"	"	"	"
X4/K2	"	23038	"	21972	"	21694
X4/BT13	"	23174	"	22667	23173	23172
X4-3	"	22525	21242	21240	21870	21781
X4-3/MT2	"	"	"	"	"	22493
X4-3/K2	"	22533	"	22535	"	21694
Z5020-X4-4	"	23030	21938	21967	"	22607
X4-4/MT2	"	"	"	"	"	22494
X4-4/MU4	"	23046	"	"	"	"
X4-4/K2	"	23038	"	21972	"	22611
X5-4	"	23032	"	21967	22600	22601
X5-4/MT2	"	"	"	"	"	22495
X5-4/MU4	"	23048	"	"	"	"
X5-4/K2	"	23040	"	21972	"	22602
Y5	21891	23034	"	21967	21864	21786
Y5/MT2	"	"	"	"	"	22497
Y5/MU4	"	23050	"	"	"	"
Y5/K2	"	23042	"	21972	"	21695
Y6	"	23036	"	21967	21865	21787
Y6/MT2	"	"	"	"	"	22496
Y6/MU4	"	23052	"	"	"	"
Y6/K2	"	23044	"	21972	"	21696
Y6-3	"	22523	21242	21240	"	21787
Y6-3/MT2	"	"	"	"	"	22496
Y6-3/K2	"	22531	"	22535	"	21696
Z5021-A6	21890	23076	21938	22054	21868	21798
A7	"	23078	"	"	21869	21799
A7-3	"	22527	21242	21245	"	"
Z5025-X4	21893	23060	21938	22064	22605	21781
X4/MT2	"	"	"	"	"	22493
X4/MU4	"	23068	"	"	"	"
X4-4	"	23060	"	"	"	22607
X4-4/MT2	"	"	"	"	"	22494
X4-4/MU4	"	23068	"	"	"	"
X5-4	"	23062	"	"	22606	22601
X5-4/MT2	"	"	"	"	"	22495
X5-4/MU4	"	23070	"	"	"	"
Y5	21891	23064	"	"	21866	21786
Y5/MT2	"	"	"	"	"	22497
Y5/MU4	"	23072	"	"	"	"
Y6	"	23066	"	"	21867	21787
Y6/MT2	"	"	"	"	"	22496
Y6/MU4	"	23074	"	"	"	"

Differential Feed Dog	Main Feed Dog	Auxiliary Feed Dog	Upper Looper	Lower Looper	Needle Guard (Front)	Needle Guard (Rear)
前送り	後送り	小送り	上ルーパ	下ルーパ	針受ケ(前)	針受ケ(後)
21846	21842	21009	21754	21701	21238	24169
〃	〃	22956	〃	〃	〃	〃
〃	〃	〃	〃	〃	〃	〃
〃	〃	21685	〃	〃	〃	〃
23170	23171	21009	〃	〃	〃	〃
21846	21842	〃	〃	〃	〃	〃
〃	〃	22956	〃	〃	〃	〃
〃	〃	21685	〃	〃	〃	〃
22608	〃	21009	〃	〃	〃	〃
〃	〃	22956	〃	〃	〃	〃
〃	〃	〃	〃	〃	〃	〃
〃	〃	21685	〃	〃	〃	〃
〃	〃	21009	〃	〃	〃	〃
〃	〃	22956	〃	〃	〃	〃
〃	〃	〃	〃	〃	〃	〃
〃	〃	21685	〃	〃	〃	〃
21847	〃	21009	〃	〃	21105	〃
〃	〃	22956	〃	〃	〃	〃
〃	〃	〃	〃	〃	〃	〃
〃	〃	21685	〃	〃	〃	〃
〃	〃	21009	〃	〃	〃	〃
〃	〃	22956	〃	〃	〃	〃
〃	〃	〃	〃	〃	〃	〃
〃	〃	21685	〃	〃	〃	〃
〃	〃	21009	〃	〃	〃	〃
〃	〃	22956	〃	〃	〃	〃
〃	〃	21685	〃	〃	〃	〃
〃	〃	21151	21758	〃	21147	〃
〃	〃	〃	〃	〃	〃	〃
〃	〃	〃	〃	〃	〃	〃
21846	〃	21009	21754	〃	21238	〃
〃	〃	22956	〃	〃	〃	〃
〃	〃	〃	〃	〃	〃	〃
22608	〃	21009	〃	〃	〃	〃
〃	〃	22956	〃	〃	〃	〃
〃	〃	〃	〃	〃	〃	〃
〃	〃	21009	〃	〃	〃	〃
〃	〃	22956	〃	〃	〃	〃
〃	〃	〃	〃	〃	〃	〃
21847	〃	21009	〃	〃	21105	〃
〃	〃	22956	〃	〃	〃	〃
〃	〃	〃	〃	〃	〃	〃
〃	〃	21009	〃	〃	〃	〃
〃	〃	22956	〃	〃	〃	〃
〃	〃	〃	〃	〃	〃	〃

Z5000 Class List of Main Spare Parts (主要部品リスト)(3)

Main Parts Models	Needle Clamp	Presser Foot Complete Set	Presser Foot Hinge	Fresser Foot (Lower)	Stitch Tongue	Stitch Plate
	針止メ	押エ(組)	押エヒンジ	押エ(下)	押エの爪	針板
Z5026-X4	21893	23112	21938	22945	22948	22952
X4/MT12	"	"	"	"	"	22953
Y5	21891	23096	"	"	22950	22954
Y5/MT12	"	"	"	"	"	22955
Z5027-X4	21893	23124	"	22980	22948	22952
X4/MT2	"	"	"	"	"	22953
Y5	21891	23136	"	"	22950	22954
Y5/MT2	"	"	"	"	"	22955
Z5037-05	21002	22817	"	22814	22816	22811
05/K2	"	22820	"	22819	"	22823
Z5045-04	"	23084	"	22153	21876	21769
04/MT2	"	"	"	"	"	22492
Z5046-Y6	21891	23086	"	"	21879	21787
Y6/MT2	"	"	"	"	"	22496
Z5056-X4	21893	23150	"	22985	22986	22952
X4/MT12	"	"	"	"	"	22953
Y5	21891	23154	"	"	22988	22954
Y5/MT12	"	"	"	"	"	22955
Z5057-X4	21893	23160	"	22990	22986	22952
X4/MT2	"	"	"	"	"	22953
Y5	21891	23164	"	"	22988	22954
Y5/MT2	"	"	"	"	"	22955

Models	Parts No. (Model Plate)	Parts No. (Threading Chart)
Z5000	20865	2534
Z5003	20866	"
Z5006	20867	"
Z5016	20868	"
Z5020	20869	2535
Z5021	20870	"
Z5025	20871	"
Z5026	20877	"
Z5027	20878	"
Z5037	20876	2546
Z5045	20872	2534
Z5046	20873	2535
Z5056	20863	"
Z5057	20864	"

Models	Parts No. (Threading Chart)
Z5003-2	2544
Z5003/BT13	2548
" /KR2	"
" /MU5	"
Z5020/BT13	2549
" /KR2	"
" /MU5	"

Differential Feed Dog	Main Feed Dog	Auxiliary Feed Dog	Upper Looper	Lower Looper	Needle Guard (Front)	Needle Guard (Rear)
前送り	後送り	小送り	上ルーパ	下ルーパ	針受ケ(前)	針受ケ(後)
22975	22020	22956	21754	21701	21238	24169
〃	〃	〃	〃	〃	〃	〃
22959	〃	〃	〃	〃	21105	〃
〃	〃	〃	〃	〃	〃	〃
22975	〃	〃	〃	〃	21238	〃
〃	〃	〃	〃	〃	〃	〃
22959	〃	〃	〃	〃	21105	〃
〃	〃	〃	〃	〃	〃	〃
22812	22813	21009	21752	22822	20223	〃
〃	〃	21685	〃	〃	〃	〃
21849	21843	21009	21700	21701	20676	〃
〃	〃	〃	〃	〃	〃	〃
21844	21845	〃	21754	〃	〃	〃
〃	〃	〃	〃	〃	〃	〃
22983	22991	22956	〃	〃	〃	〃
〃	〃	〃	〃	〃	〃	〃
22984	22992	〃	〃	〃	〃	〃
〃	〃	〃	〃	〃	〃	〃
22983	22991	〃	〃	〃	〃	〃
〃	〃	〃	〃	〃	〃	〃
22984	22992	〃	〃	〃	〃	〃
〃	〃	〃	〃	〃	〃	〃

Device Indicate Plate and Parts No.			
/K2	18710	/MU4	18730
-3/K2	18762	-3/MU4	18736
-4/K2	18767	-4/MU4	18737
/KT2	18715	/MU5	18731
-3/KT2	18717	/TC/CH20	18748
-4/KT2	18787	/BT13	18724
/KR2	18720	-2/B3	18725
-3/KR2	18765	-2	18703
-4/KR2	18788	-3	18704
/MT2	18732	-4	18722
-3/MT2	18734		
-4/MT2	18735		
/MT12	18733		

Gauge Indicate Plate and Parts No.			
02DF	20860	X4DF	20791
02DA	20861	X4DA	20792
03DF	20850	X5DF	20798
03DA	20851	X5DA	20799
04DF	20852	Y5DF	20817
04DA	20853	Y5DA	20818
05DF	20854	Y6DF	20814
05DA	20855	Y6DA	20815
06DF	20856	A6DF	20819
06DA	20857	A6DA	20820
		A7DF	20823
		A7DA	20824

Z5000

INDEX

Parts No.	Page No.	Ref. No.	Weight (g)
2	40	57	0.1
2	43	35	0.1
2	48	39	0.1
10	50	21	0.2
12	48	40	0.5
14	37	16	2
14	38	16	2
14	46	16	2
14	47	16	2
14	48	38	2
14	54	16	2
14	55	16	2
15	14	34	0.7
15	59	36	0.7
21	37	21	—
21	38	21	—
21	46	21	—
21	47	21	—
21	55	21	—
21	54	21	—
23	51	28	—
56	50	18	3.4
147	59	5	4
148	59	6	0.5
149	59	8	1.5
150	59	9	0.8
151	59	11	4.5
152	59	12	1.5
153	59	15	1
154	59	14	5
156	59	19	1
157	59	22	0.7
158	59	26	2
159	59	27	3
160	59	47	22.5
161	59	50-1	5.5
161	59	50-2	5.5
162	59	49-1	3.9
162	59	49-2	3.9
163	59	52	51
164	59	48	27
165	59	53	21.5
170	7	26	0.25
171	6	43	0.003
171	10	25	0.003
172	16	28	0.2
172	25	17	0.2
172	57	35	0.2
174	6	31	0.1
177	4	7	0.06
177	18	8	0.06
177	19	10	0.06
177	20	10	0.06
177	21	8	0.06
177	23	8	0.06

Parts No.	Page No.	Ref. No.	Weight (g)
177	28	8	0.06
177	30	8	0.06
177	37	38	0.06
177	38	38	0.06
177	46	38	0.06
177	47	38	0.06
177	50	10	0.06
177	54	38	0.06
177	55	38	0.06
178	4	5	0.3
178	18	6	0.3
178	19	8	0.3
178	20	8	0.3
178	21	6	0.3
178	23	6	0.3
178	28	6	0.3
178	30	6	0.3
178	37	7	0.3
178	38	37	0.3
178	46	37	0.3
178	47	37	0.3
178	50	8	0.3
178	54	37	0.3
178	55	37	0.3
180	14	29	0.2
181	12	54	13
183	6	18	4.4
184	1	39	3.2
185	12	49	2.7
185	51	4	2.7
186	12	51	1
187	39	14	0.03
187	42	17	0.03
192	12	29	0.5
193	12	9	0.3
194	6	15	0.2
195	6	26	0.2
198	7	22	0.45
199	6	38	0.02
203	10	26	0.25
223	13	5	—
240	7	23	—
278	10	20	0.03
286	37	6	0.1
286	38	6	0.1
286	46	6	0.1
286	47	6	0.1
286	54	6	0.1
286	55	6	0.1
306	48	15	1.3
322	39	10	0.3
330	37	25	0.45

Parts No.	Page No.	Ref. No.	Weight (g)
330	38	25	0.45
330	46	25	0.45
330	47	25	0.45
330	54	25	0.45
330	55	25	0.45
331	37	28	0.6
331	38	28	0.6
331	46	28	0.6
331	47	28	0.6
331	54	28	0.6
331	55	28	0.6
334	6	10	0.6
334	9	19	0.6
334	16	30	0.6
334	22	6	0.6
334	25	6	0.6
334	26	6	0.6
334	29	6	0.6
334	32	16	0.6
334	50	14	0.6
334	57	25	0.6
335	1	17	0.8
335	23	35	0.8
335	27	21	0.8
335	30	33	0.8
335	35	12	0.8
335	42	7	0.8
335	49	7	0.8
335	52	12	0.8
340	12	57	0.5
340	18	11	0.5
340	19	13	0.5
340	20	13	0.5
340	21	11	0.5
340	23	11	0.5
340	27	17	0.5
340	28	11	0.5
340	30	11	0.5
340	39	16	0.5
340	42	18	0.5
347	22	10	0.95
347	26	10	0.95
347	29	10	0.95
355	23	28	0.85
355	27	13	0.85
355	30	26	0.85
361	53	19	0.5
361	56	10	0.5
376	14	44	—
377	7	8	—
396	2	33	1
397	5	8	—
398	12	26	—
419	14	2	1

INDEX

Parts No.	Page No.	Ref. No.	Weight (g)
444	4	27	0.09
451	12	11	1.5
461	9	2	8.5
488	40	58	—
488	43	36	—
496	37	32	1
496	38	32	1
496	46	32	1
496	47	32	1
496	54	32	1
496	55	32	1
500	57	24	1.5
507	10	11	—
519	23	27	0.1
519	27	12	0.1
519	30	25	0.1
520	6	7	0.3
520	8	7	0.3
520	10	17	0.3
520	11	16	0.3
520	12	7	0.3
520	12	56	0.3
528	1	4	1.85
528	17	3	1.85
531	22	20	0.23
531	26	20	0.23
531	29	20	0.23
532	1	14	0.3
532	4	31	0.3
532	8	23	0.3
532	15	14	0.3
532	35	4	0.3

532	39	7	0.3
532	42	9	0.3
532	46	41	0.3
532	47	41	0.3
532	52	4	0.3
533	16	23	0.3
533	48	9	0.3
538	2	49	0.4
538	14	13	0.4
538	22	5	0.4
538	23	13	0.4
538	26	5	0.4
538	28	13	0.4
538	29	5	0.4
538	30	13	0.4
538	39	3	0.4
538	40	50	0.4
538	42	2	0.4
538	43	24	0.4
538	51	26	0.4

Parts No.	Page No.	Ref. No.	Weight (g)
542	35	15	0.3
542	44	11	0.3
542	52	15	0.3
550	3	26	0.03
550	6	12	0.03
550	35	9	0.03
550	52	9	0.03
561	12	55	0.45
567	7	4	0.07
567	14	8	0.07
568	39	24	0.13
568	42	28	0.13
613	48	14	1
621	48	12	—
622	50	24	—
629	5	37	—
632	23	32	—
632	27	18	—
632	30	30	—
636	6	39	0.02
636	10	9	0.02
637	11	7	0.07
637	12	27	0.07
638	10	5	0.16
638	11	12	0.16
638	14	9	0.16
639	6	32	0.32
639	8	13	0.32
639	12	19	0.32
644	39	4	0.8
644	42	3	0.8
644	51	27	0.8
644	59	34	0.8
651	14	10	0.98
652	2	21	—
665	59	35	—
687	12	17	0.1
688	11	24	2
726	2	18	0.04
740	5	9	0.1
755	6	27	0.2
755	7	9	0.2
755	12	10	0.2
916	2	11	—
930	6	44	0.4
932	17	5	1
933	17	4	1
1016	2	31	0.5
1049	48	27	—
1132	1	22	1.3
1156	6	52	2.2

Parts No.	Page No.	Ref. No.	Weight (g)
1170	1	18	0.1
1170	5	15	0.1
1175	22	13	0.92
1175	26	13	0.92
1175	29	13	0.92
1175	35	14	0.92
1175	48	10	0.92
1175	52	14	0.92
1175	57	17	0.92
1196	16	37	0.5
1202	9	10	0.8
1202	11	5	0.8
1202	49	10	0.8
1203	21	16	0.1
1203	40	34	0.1
1203	43	7	0.1
1208	7	14	0.6
1222	32	38	0.5
1227	4	28	0.3
1227	16	38	0.3
1227	25	27	0.3
1227	57	44	0.3
1228	2	26	0.2
1228	9	44	0.2
1228	15	23	0.2
1228	18	21	0.2
1228	19	22	0.2
1228	20	23	0.2
1228	21	24	0.2
1228	24	13	0.2
1228	25	6	0.2
1228	27	37	0.2
1228	28	21	0.2
1228	31	13	0.2
1228	33	6	0.2
1228	34	9	0.2
1228	45	6	0.2
1228	54	48	0.2
1228	55	48	0.2
1228	56	21	0.2
1228	57	6	0.2
1228	58	6	0.2
1230	21	29	0.2
1230	32	34	0.2
1230	40	44	0.2
1230	43	17	0.2
1230	45	22	0.2
1230	57	13	0.2
1230	58	19	0.2
1326	4	25	1
1330	2	36	0.6
1330	4	32	0.6
1330	16	32	0.6
1330	23	48	0.6
1330	25	15	0.6

INDEX

Parts No.	Page No.	Ref. No.	Weight (g)
1330	30	46	0.6
1330	57	33	0.6
1331	40	39	—
1331	43	12	—
1333	48	16	0.9
1396	38	11	0.8
1396	37	11	0.8
1396	46	11	0.8
1396	47	11	0.8
1396	54	11	0.8
1396	55	11	0.8
1399	49	27	0.2
1457	10	8	0.59
1459	1	10	0.1
1459	6	40	0.1
1892	32	50	0.1
1892	44	21	0.1
1904	50	16	3.6
1923	53	20	1.15
1923	56	11	1.15
3312	39	19	0.1
3312	42	21	0.1
3313	10	21	0.1
3405	13	15	1
3434	5	13	0.4
3434	6	24	0.4
3436	13	16	0.6
3556	23	29	1.4
3556	27	14	1.4
3556	30	27	1.4
3632	2	2	1.7
3632	7	16	1.7
3632	13	2	1.7
3635	5	26	0.9
3636	13	6	0.9
3637	2	47	0.1
3637	6	48	0.1
3637	9	5	0.1
3637	15	32	0.1
3637	16	7	0.1
3637	18	13	0.1
3637	19	3	0.1
3637	20	3	0.1
3637	21	31	0.1
3637	23	33	0.1
3637	24	4	0.1
3637	27	19	0.1
3637	28	15	0.1
3637	30	31	0.1
3637	31	2	0.1
3637	40	37	0.1
3637	43	10	0.1
3637	49	11	0.1
3637	53	15	0.1

Parts No.	Page No.	Ref. No.	Weight (g)
3637	56	6	0.1
3638	6	28	0.5
3638	7	11	0.5
3638	8	32	0.5
3638	10	41	0.5
3638	11	18	0.5
3638	13	28	0.5
3638	22	15	0.5
3638	23	50	0.5
3638	30	48	0.5
3638	26	15	0.5
3638	29	15	0.5
3638	48	29	0.5
3639	9	28	2
3646	1	28	0.9
3654	5	16	3.5
4096	9	36	—
4097	9	38	—
4099	13	26	—
4100	12	35	3
4100	22	23	3
4100	26	23	3
4100	29	23	3
4100	50	22	3
4100	57	23	3
4102	59	31	9.7
4103	9	16	13.5
4104	15	9	1.8
4105	15	5	0.3
4106	8	24	1.1
4106	8	26	1.1
4106	16	44	1.1
4107	9	14	3
4108	5	6	0.4
4108	14	23	0.4
4109	13	24	0.4
4110	12	45	4.6
4111	12	53	4
4115	14	24	6.7
4116	14	28	1
4117	1	21	4.5
4118	12	44	0.6
4119	9	1	27
4122	2	15	8.3
4123	5	2	1.5
4124	14	7	4
4125	18	9	5
4125	19	11	5
4125	20	11	5
4125	21	9	5
4125	23	9	5
4125	28	9	5
4125	30	9	5
4126	14	39	5.3

Parts No.	Page No.	Ref. No.	Weight (g)
4127	59	38	0.8
4130	11	21	0.01
4131	9	47	0.6
4131	15	26	0.6
4131	16	15	0.6
4131	17	15	0.6
4131	18	24	0.6
4131	19	25	0.6
4131	20	26	0.6
4131	21	27	0.6
4131	24	16	0.6
4131	25	9	0.6
4131	27	40	0.6
4131	28	24	0.6
4131	31	16	0.6
4131	33	9	0.6
4131	34	7	0.6
4131	45	9	0.6
4131	51	37	0.6
4131	54	46	0.6
4131	55	46	0.6
4131	56	24	0.6
4131	57	9	0.6
4131	58	9	0.6
4132	22	16	0.8
4132	26	16	0.8
4132	29	16	0.8
4132	35	2	0.8
4132	39	12	0.8
4132	42	13	0.8
4132	52	2	0.8
4133	6	42	—
4137	4	21	1
4138	15	40	0.75
4138	18	39	0.75
4138	19	37	0.75
4138	20	38	0.75
4138	33	23	0.75
4138	34	15	0.75
4138	58	15	0.75
4139	49	13	—
4143	12	42	2.5
4144	10	32	0.28
4145	3	23	2
4146	12	48	5.85
4147	8	18	2
4148	32	42	1
4150	16	29	0.46
4150	25	18	0.46
4150	57	36	0.46
4151	37	12	3
4151	38	12	3
4151	46	12	3
4151	47	12	3
4151	54	12	3

INDEX

Parts No.	Page No.	Ref. No.	Weight (g)
4151	55	12	3
4153	8	17	1.03
4155	6	46	—
4204	17	19	—
4205	53	17	4.5
4205	56	8	4.5
4236	17	12	0.34
4236	25	11	0.34
4236	33	28	0.34
4236	49	4	0.34
4237	32	30	0.2
4237	49	24	0.2
4312	2	20	0.58
4312	37	27	0.58
4312	38	27	0.58
4312	46	27	0.58
4312	47	27	0.58
4312	54	27	0.58
4312	55	27	0.58
4314	3	12	0.4
4351	9	41	0.9
4351	15	20	0.9
4351	16	11	0.9
4351	17	8	0.9
4351	18	18	0.9
4351	19	19	0.9
4351	20	20	0.9
4351	21	21	0.9
4351	24	10	0.9
4351	25	3	0.9
4351	27	34	0.9
4351	28	18	0.9
4351	31	10	0.9
4351	33	3	0.9
4351	34	3	0.9
4351	45	3	0.9
4351	49	22	0.9
4351	51	33	0.9
4351	54	42	0.9
4351	55	42	0.9
4351	56	18	0.9
4351	57	3	0.9
4351	58	3	0.9
4352	35	11	1.3
4352	42	6	1.3
4352	48	32	1.3
4352	52	11	1.3
4353	4	14	0.9
4353	7	24	0.9
4353	13	12	0.9
4353	22	26	0.9
4353	26	26	0.9
4353	29	26	0.9
4353	39	8	0.9
4353	40	32	0.9

Parts No.	Page No.	Ref. No.	Weight (g)
4353	42	10	0.9
4353	43	5	0.9
4353	48	6	0.9
4353	51	3	0.9
4358	1	3	0.9
4358	10	34	0.9
4358	32	39	0.9
4358	35	5	0.9
4358	37	14	0.9
4358	38	14	0.9
4358	42	12	0.9
4358	46	14	0.9
4358	47	14	0.9
4358	48	25	0.9
4358	52	5	0.9
4358	54	14	0.9
4358	55	14	0.9
4358	57	21	0.9
4401	23	18	0.3
4401	44	9	0.3
4404	6	57	0.25
4404	15	4	0.25
4404	32	36	0.25
4404	35	18	0.25
4404	44	5	0.25
4404	52	18	0.25
4406	3	25	1.18
4406	48	35	1.18
4406	50	19	1.18
4410	10	4	2
4410	13	21	2
4435	3	41	1.05
4437	3	14	1.5
4437	11	8	1.5
4440	2	45	1.5
4440	7	10	1.5
4440	8	34	1.5
4440	18	37	1.5
4440	25	28	1.5
4440	35	10	1.5
4440	49	33	1.5
4440	52	10	1.5
4440	57	30	1.5
4441	2	16	2.2
4441	3	11	2.2
4441	6	13	2.2
4591	8	29	2.4
4591	23	39	2.4
4591	27	25	2.4
4591	30	37	2.4
4635	3	17	4
4635	39	21	4
4635	42	23	4
5000	23	41	0.62

Parts No.	Page No.	Ref. No.	Weight (g)
5000	27	27	0.62
5000	30	39	0.62
5000	48	18	0.62
5004	14	30	2.3
5036	16	22	0.6
5036	23	16	0.6
5036	27	3	0.6
5036	30	16	0.6
5036	49	5	0.6
5038	12	52	2
5038	39	27	2
5038	42	25	2
5038	48	42	2
5040	32	12	2
5043	3	2	1.76
5043	23	44	1.76
5043	27	30	1.76
5043	30	42	1.76
5055	13	34	—
5062	58	32	2.8
5070	6	2	5
5070	8	2	5
5070	10	2	5
5070	11	2	5
5076	1	30	8
5076	59	46	8
5078	3	8	—
5083	2	4	3.85
5089	1	8	4
5094	3	29	1.7
5098	40	30	1.5
5098	43	3	1.5
5108	1	38	6
5108	6	19	6
5108	10	12	6
5108	11	10	6
5127	39	15	—
5127	42	16	—
5128	37	20	—
5128	38	20	—
5128	46	20	—
5128	47	20	—
5128	54	20	—
5128	55	20	—
5133	2	23	0.5
5343	2	13	0.78
5345	3	6	0.9
5345	6	50	0.9
5345	23	12	0.9
5345	28	12	0.9
5345	30	12	0.9
5500	11	15	5
5505	9	20	2.1
5505	32	17	2.1
5506	25	21	1.5

INDEX

Parts No.	Page No.	Ref. No.	Weight (g)
5506	36	10	1.5
5506	44	32	1.5
5506	51	15	1.5
5506	53	10	1.5
5506	57	38	1.5
5512	12	34	1
5512	51	10	1
5520	6	6	5
5520	8	6	5
5520	12	6	5
5522	10	18	10
5550	8	12	3
5550	9	24	3
5550	12	2	3
5550	48	20	3
5585	48	26	—
5587	51	8	—
5588	48	44	—
5589	48	11	—
5591	49	30	—
5598	49	14	—
6068	39	25	2.5
6068	42	29	2.5
6075	22	4	2.4
6075	26	4	2.4
6075	29	4	2.4
6092	37	24	2
6092	38	24	2
6092	46	24	2
6092	47	24	2
6092	54	24	2
6092	55	24	2
6094	9	12	0.5
6142	23	31	3.11
6142	27	16	3.11
6142	30	29	3.11
6150	22	9	2
6150	26	9	2
6150	29	9	2
6405	9	8	0.6
6444	16	41	—
6816	1	37	6.5
6820	49	8	—
6905	32	3	2
6910	36	7	5
6910	40	64	5
6910	44	29	5
6910	51	18	5
6910	53	7	5
7006	1	16	0.7
7006	16	24	0.7
7006	23	22	0.7
7006	27	7	0.7

Parts No.	Page No.	Ref. No.	Weight (g)
7006	30	20	0.7
7128	6	36	0.8
7302	23	25	0.34
7302	27	10	0.34
7302	30	23	0.34
7311	10	39	1.9
7405	8	21	1.2
7405	15	17	1.2
7405	57	29	1.2
7605	22	25	1.04
7605	26	25	1.04
7605	29	25	1.04
7606	48	37	2
7609	13	8	1.15
7609	23	34	1.15
7609	27	20	1.15
7609	30	32	1.15
7609	36	3	1.15
7609	44	35	1.15
7609	49	19	1.15
7609	51	12	1.15
7609	53	3	1.15
7616	12	31	0.36
7616	25	24	0.36
7616	57	41	0.36
7619	7	19	0.34
7619	14	14	0.34
7619	16	43	0.34
7645	5	10	0.4
7650	1	6	0.35
7650	9	26	0.35
7668	14	42	4
7904	4	8	5
7904	37	8	5
7904	38	8	5
7904	46	8	5
7904	47	8	5
7904	50	11	5
7904	54	8	5
7904	55	8	5
8076	58	34	7.5
8101	11	3	1.6
9121	2	41	0.6
9121	11	20	0.6
9127	9	18	1.1
9143	1	13	0.4
9143	40	67	0.4
9143	44	39	0.4
9150	1	33	2
9150	14	20	2
9150	16	45	2
9150	21	14	2
9150	40	51	2
9150	43	25	2

Parts No.	Page No.	Ref. No.	Weight (g)
9150	48	2	2
9209	36	4	0.5
9209	44	36	0.5
9209	51	13	0.5
9209	53	4	0.5
9508	6	4	1
9508	8	4	1
9508	10	28	1
9508	13	29	1
9508	53	22	1
9508	56	14	1
9508	57	47	1
9604	1	24	0.9
9604	2	38	0.9
9604	6	9	0.9
9604	8	9	0.9
9604	12	38	0.9
9624	12	24	0.4
9624	16	26	0.4
9730	13	10	0.6
9730	32	28	0.6
9843	37	33	—
9843	46	33	—
9843	54	33	—
9853	3	35	1.6
9853	4	17	1.6
9853	13	31	1.6
9853	35	16	1.6
9853	44	12	1.6
9853	52	16	1.6
9860	59	33	—
9909	7	5	2
9909	14	31	2
9930	12	47	6
9930	51	5	6
9931	3	39	2.8
9944	3	27	—
9989	14	33	1
9992	39	5	2
9992	42	4	2
9992	58	30	2
9992	59	41	2
9993	40	54	2.5
9993	43	32	2.5
9994	37	17	0.25
9994	38	17	0.25
9994	46	17	0.25
9994	47	17	0.25
9994	54	17	0.25
9994	55	17	0.25
9995	37	19	0.4
9995	38	19	0.4
9995	40	56	0.4
9995	43	34	0.4
9995	46	19	0.4

INDEX

Parts No.	Page No.	Ref. No.	Weight (g)
9995	47	19	0.4
9995	54	19	0.4
9995	55	19	0.4
9995	59	43	0.4
10100	32	4	117
10100	44	17	117
11180	51	19	—
11182	51	20	—
11183	51	22	—
11189	51	25	—
11190	48	19	—
11191	48	36	—
11192	51	23	—
11193	51	1	—
11323	36	5	—
11709	36	6	48
11709	40	63	48
11709	44	28	48
11709	51	17	48
11709	53	6	48
11753	40	48	73
11754	43	30	5
11760	39	13	655
11839	37	5	150
11839	38	15	150
11839	54	15	150
11839	55	15	150
11840	35	7	20
11840	52	7	20
11841	35	8	5
11841	52	8	5
11848	53	5	—
11880	36	9	20
11880	53	9	20
11888	35	17	42
11888	52	17	42
11926	43	22	—
11928	43	27	—
11930	44	24	—
11933	44	31	—
11933	51	14	—
11934	44	1	—
11935	44	4	—
11941	42	15	—
11942	46	15	—
11942	47	15	—
11943	44	23-1	—
11943	51	29-1	—
11944	44	23-2	—
11944	51	29-2	—
11945	44	23-3	—
11945	51	29-3	—
11946	44	23-4	—
11946	51	29-4	—

Parts No.	Page No.	Ref. No.	Weight (g)
11949	44	6	—
11954	40	62-1	—
11959	40	62-2	—
11967	40	52	—
11973	44	27	—
11974	44	26	—
11974	51	21	—
11975	44	25	—
11987	42	5	—
20003	2	5	12
20004	2	8	8
20005	2	9	1.25
20014	2	40	0.4
20015	2	44	130
20016	2	46	11.8
20017	2	51	1.6
20019	14	16	0.8
20020	14	15	0.7
20034	1	2	315
20035	1	12	10.2
20036	1	19	12.4
20038	1	20	1.8
20039	59	30	88
20043	3	10	19.5
20045	59	55	9.3
20046	3	19	3.5
20047	3	18	12
20047	1	34	1.5 kg
20049	1	35	88
20051	3	21	0.9
20052	3	20	1.6
20053	1	36	12.5
20054	1	25	68
20056	1	27	20.5
20057	59	54	246
20060	3	5	25
20061	3	7	3
20064	59	51	2.4
20068	59	32	363
20069	59	37	414
20072	3	15	0.5
20072	6	54	0.5
20076	59	42	32
20077	59	40	—
20078	59	39	120
20079	2	37	—
20080	1	40	20.5
20100	18	10	24.5
20100	19	12	24.5
20100	20	12	24.5
20100	21	10	24.5
20101	4	12	9
20101	37	31	9
20101	38	31	9

Parts No.	Page No.	Ref. No.	Weight (g)
20101	46	31	9
20101	47	31	9
20101	54	31	9
20101	55	31	9
20102	4	10	2.5
20102	37	30	2.5
20102	38	30	2.5
20102	46	30	2.5
20102	47	30	2.5
20102	50	12	2.5
20102	54	30	2.5
20102	55	30	2.5
20103	4	11	2.1
20103	37	4	2.1
20103	38	4	2.1
20103	46	4	2.1
20103	47	4	2.1
20103	50	6	2.1
20103	54	4	2.1
20103	55	4	2.1
20104	4	1	8.5
20104	18	2	8.5
20104	19	4	8.5
20104	20	4	8.5
20104	21	2	8.5
20104	23	2	8.5
20104	28	2	8.5
20104	30	2	8.5
20104	37	34	8.5
20104	38	34	8.5
20104	46	34	8.5
20104	47	34	8.5
20104	50	4	8.5
20104	54	34	8.5
20104	55	34	8.5
20108	4	30	1.2
20110	4	29	0.8
20112	10	33	2.8
20118	4	4	0.95
20118	18	5	0.95
20118	19	7	0.95
20118	20	7	0.95
20118	21	5	0.95
20118	23	5	0.95
20118	28	5	0.95
20118	30	5	0.95
20118	37	36	0.95
20118	38	36	0.95
20118	46	36	0.95
20118	47	36	0.95
20118	50	7	0.95
20118	54	36	0.95
20118	55	36	0.95
20131	4	20	0.1
20132	4	3	1.9

INDEX

Parts No.	Page No.	Ref. No.	Weight (g)
20132	37	35	1.9
20132	38	33	1.9
20132	46	35	1.9
20132	47	33	1.9
20132	50	23	1.9
20132	54	35	1.9
20132	55	33	1.9
20154	5	3	64
20155	5	5	51
20156	5	12	172
20157	5	14	90.8
20158	5	17	63
20159	5	11	53.5
20161	3	28	0.82
20180	6	1	40.5
20185	5	22	30.5
20186	5	23	44.5
20187	5	24	0.8
10189	6	22	2
20190	6	35	1.3
20191	6	25	4.8
20192	6	21	41
20193	6	23	13
20195	6	37	2.2
20198	6	16	28.5
20199	6	17	24
20220	6	51	62
20223	6	56	2.3
20225	7	15	5.6
20228	3	37	8
20230	7	12	10.3
20237	6	20	60
20238	6	55	3.3
20271	9	37	0.5
20276	9	29	49
20279	9	23	30
20280	9	22	1.6
20281	9	21	7
20282	9	15	57.7
20283	9	17	11
20293	9	11	0.6
20299	9	27	80
20300	9	25	14
20301	22	27	1.4
20301	26	27	1.4
20301	29	27	1.4
20311	11	4	7
20316	5	29	36
20318	10	16	43.2
20320	10	24	7.4
20322	10	38	11
20323	10	40	4.9
20325	14	12	0.8

Parts No.	Page No.	Ref. No.	Weight (g)
20330	10	35	1.5
20331	10	19	3
20334	5	27	1.8
20341	11	6	10.9
20342	11	9	40
20343	11	13	44
20344	5	30	26
20345	5	31	31.5
20376	7	13	5.4
20400	13	17	45
20401	13	18	3.6
20406	13	20	45
20408	12	21	58
20410	5	34	15
20411	5	33	15
20412	5	32	23
20413	12	22	6
20414	12	23	1.9
20418	12	41	26
20420	12	50	2.3
20421	12	43	3
29425	12	8	12.5
20426	12	14	41.3
20427	12	15	43.3
20428	13	30	8
20429	13	38	6.25
20430	13	35	1.3
20432	13	13	17
20433	13	36	5.6
20436	12	39	4.8
20442	12	13	92
20445	12	1	17
20447	12	20	68
20450	13	32	26
20452	13	22	36
20454	13	25	0.24
20455	13	27	13
20470	3	30	15.5
20472	3	32	0.09
20480	8	1	25
20483	5	20	29.5
20484	5	19	4.1
20485	5	18	20.5
20487	8	10	2.4
20489	15	3	0.2
20490	8	19	1
20491	15	6	5
20492	15	7	2.7
20496	8	22	2.8
20497	8	28	3.1
20520	14	22	32
20526	14	21	445
20530	14	25	5

Parts No.	Page No.	Ref. No.	Weight (g)
20531	14	26	15
20532	14	27	22
20534	14	1	2.3
20535	14	6	50
20538	3	9	0.1
20539	14	40	26
20546	14	19	42
20550	6	14	0.8
20552	14	43	—
20554	14	35	—
20611	23	20	6.9
20611	27	5	6.9
20611	30	18	6.9
20612	27	2	—
20612	30	15	—
20616	23	42	—
20616	27	28	—
20616	30	40	—
20630	23	30	61.5
20630	27	15	61.5
20630	30	28	61.5
20631	23	23	6.9
20631	27	8	6.9
20631	30	21	6.9
20651	7	3	4
20659	2	29	1.4
20660	2	35	0.5
20663	15	27	12.5
20663	18	28	12.5
20663	19	26	12.5
20663	20	27	12.5
20667	4	16	7
20676	27	31	—
20676	31	3	—
20686	23	47-1	16
20686	30	45	16
20688	23	47-2	16
20700	57	45	75
20988	39	26	33
20988	42	24	33
20989	40	53	13.2
21001	4	9	11
21001	37	39	11
21001	38	39	11
21001	46	39	11
21001	47	39	11
21001	54	39	11
21001	55	39	11
21002	6	45	2
21005	9	46	0.5
21005	15	25	0.5
21005	16	14	0.5

INDEX

Parts No.	Page No.	Ref. No.	Weight (g)
21005	17	14	0.5
21005	18	23	0.5
21005	19	24	0.5
21005	20	25	0.5
21005	21	26	0.5
21005	24	25	0.5
21005	25	8	0.5
21005	27	39	0.5
21005	28	23	0.5
21005	31	15	0.5
21005	33	8	0.5
21005	34	6	0.5
21005	45	8	0.5
21005	51	36	0.5
21005	54	45	0.5
21005	55	45	0.5
21005	56	23	0.5
21005	57	8	0.5
21005	58	8	0.5
21006	3	36	7
21009	13	9	2.5
21010	14	11	—
21015	9	35	1
21018	9	33	1.5
21018	15	31	1.5
21018	16	6	1.5
21018	18	32	1.5
21018	19	30	1.5
21018	20	31	1.5
21021	3	24	—
21058	32	27	0.1
21065	45	21	3
21105	19	16	2.2
21105	21	39	2.2
21105	24	22	2.2
21117	8	33	2.9
21124	7	20	13.4
21125	7	18	—
21126	7	17	—
21136	7	25	2.3
21147	20	17	2
21151	20	16	10
21165	21	28	3
21165	57	12	3
21165	58	18	3
21188	2	19	3
21191	13	33	0.02
21194	17	17	12
21195	17	20	3
21196	17	9	20
21197	17	16	—
21201	17	22	18
21202	17	13	0.01
21204	17	1	18

Parts No.	Page No.	Ref. No.	Weight (g)
21205	17	2	7
21215	17	25	—
21216	17	18	0.3
21217	17	24	35
21218	17	23	2
21220	17	26	4
21238	18	14	2.2
21238	21	32	2.2
21238	24	7	2.2
21240	15	36	18
21240	18	36	18
21240	19	34	18
21242	15	35	—
21242	18	35	—
21242	19	33	—
21242	20	34	—
21242	33	19	—
21242	34	13	—
21242	58	11	—
21243	15	37	—
21243	18	37	—
21243	19	35	—
21243	20	36	—
21243	33	21	—
21243	34	16	—
21243	58	13	—
21245	20	35	—
21301	17	11	2
21301	33	5	2
21328	59	44	1 kg
21337	16	20	45
21450	32	48	—
21450	44	19	—
21451	32	47	62
21451	44	18	62
21456	32	49	20
21456	44	20	20
21457	32	51	20
21457	44	22	20
21484	39	23	7
21484	42	27	7
21539	36	8	3
21539	44	33	3
21539	51	16	3
21539	53	8	3
21547	51	11	10
21667	32	29	—
21668	32	35	5
21669	8	14	—
21673	32	26	—
21674	32	25	85
21675	32	31	3
21677	32	33	8

Parts No.	Page No.	Ref. No.	Weight (g)
21680	32	32	8
21682	32	40	3
21683	32	41	1
21684	8	15	2
21685	32	46	2
21686	33	10-1	12
21687	33	10-2	12
21688	33	10-3	12
21690	33	17-1	12
21691	33	17-2	12
21692	33	17-3	12
21693	33	17-4	12
21694	34	10	12
21695	34	18-1	12
21696	34	18-2	12
21699	32	24	—
21700	10	30	1.6
21701	11	17	5
21703	11	14	36.6
21705	10	31	1.2
21713	4	24	42.7
21714	4	26	0.6
21717	11	19	3.6
21720	4	23	1.8
21721	5	28	27
21722	6	5	42.7
21724	6	11	0.5
21725	1	7	57
21726	4	22	1.1
21727	1	1	390
21728	2	39	61.5
21731	3	38	24
21737	3	13	168
21739	32	44	8
21739	40	47	8
21739	43	21	8
21746	32	43	150
21752	25	32	1.6
21754	18	15	1.6
21754	19	14	1.6
21754	21	18	1.6
21754	23	45	1.6
21754	28	25	1.6
21754	30	43	1.6
21758	20	14	—
21759	16	16-1	12
21761	16	16-2	25
21763	16	16-3	12
21768	6	49-1	12
21769	6	49-2	12
21774	6	49-3	12
21775	6	49-4	12
21781	18	25	12
21781	21	33	12
21786	19	15-1	12

INDEX

Parts No.	Page No.	Ref. No.	Weight (g)
21786	21	40-1	12
21787	19	15-2	12
21787	21	40-2	12
21787	28	26	12
21798	20	15-1	12
21799	20	15-2	12
21840	16	17	17
21841	16	18	7
21842	13	7	8
21843	27	42	8
21844	28	27	17
21845	28	28	7
21846	13	11-1	16.5
21847	13	11-2	16.5
21849	27	41	12.5
21855	4	18	0.6
21856	4	19	0.6
21860	8	5	57.5
21864	19	23-1	3
21864	34	20-1	3
21864	45	14-3	3
21864	57	7-3	3
21864	58	7-3	3
21865	19	23-2	3
21865	34	20-2	3
21865	45	14-4	3
21865	57	7-4	3
21865	58	7-4	3
21866	21	37-1	3
21866	45	20-3	3
21866	57	14-2	3
21866	58	20-1	3
21867	21	37-2	3
21867	45	20-4	3
21867	57	14-3	3
21867	58	20-2	3
21868	20	24-1	4
21869	20	24-2	4
21870	18	22-1	2.2
21870	34	5-1	2.2
21870	45	14-1	2.2
21870	57	7-2	2.2
21870	58	7-2	2.2
21871	9	45-1	1.9
21871	33	16-1	1.9
21871	45	7-1	1.9
21872	9	45-2	2.2
21872	15	39	2.2
21872	33	16-2	2.2
21872	45	7-2	2.2
21872	57	7-1	2.2
21872	58	7-1	2.2
21873	9	45-3	2.6
21873	33	16-3	2.6

Parts No.	Page No.	Ref. No.	Weight (g)
21873	45	7-3	2.6
21874	9	45-4	3
21874	33	16-4	3
21874	45	7-4	3
21876	27	38	5
21879	28	22	0.04
21880	16	13-1	4
21880	33	7-1	4
21881	16	13-2	4
21881	33	7-2	4
21882	16	13-3	5
21882	33	7-3	5
21884	15	24	5
21888	1	11	11.6 kg
21889	5	25	12.5
21890	20	2	5
21891	19	2	2
21891	21	38	2
21891	24	19	2
21891	28	14	2
21891	31	19	2
21893	18	12	2
21893	21	30	2
21893	24	3	2
21893	31	1	2
21928	32	45	15
21938	9	40	4.5
21938	15	19	4.5
21938	16	10	4.5
21938	17	7	4.5
21938	18	17	4.5
21938	19	18	4.5
21938	20	19	4.5
21938	21	20	4.5
21938	24	9	4.5
21938	25	2	4.5
21938	27	33	4.5
21938	28	17	4.5
21938	31	9	4.5
21938	33	2	4.5
21938	34	2	4.5
21938	45	2	4.5
21938	51	32	4.5
21938	54	1	4.5
21938	55	41	4.5
21938	56	17	4.5
21938	57	2	4.5
21938	58	2	4.5
21939	16	12	1
21940	16	9-1	30
21941	16	9-2	75
21942	16	9-3	75
21946	33	4	18
21947	33	1-1	75
21948	33	1-2	75

Parts No.	Page No.	Ref. No.	Weight (g)
21949	33	1-3	75
21960	33	12	18
21961	33	11-1	70
21962	33	11-2	70
21963	33	11-3	70
21967	9	42	18
21967	15	21	18
21967	18	19	18
21967	19	20	18
21967	45	4	18
21967	45	13	18
21967	54	43	18
21967	56	19	18
21972	33	14	18
21972	34	4	18
21982	58	4	18
21983	58	17	18
21984	58	12	18
22015	58	23	—
22016	58	22	—
22017	58	24	—
22018	58	25	—
22019	58	26	—
22020	24	1	—
22020	58	27	—
22021	58	21	—
22054	20	21	18
22064	21	22	18
22064	45	19	18
22153	27	35	7
22153	28	19	7
22181	9	3	7.5
22195	8	27	6.25
22196	8	25	51
22197	9	4	4.5
22198	15	1	4
22215	4	15	—
22239	16	3	20
22240	16	8	2
22248	21	12	15.8
22249	21	15	5.6
22252	9	34	34.4
22253	15	33	33
22253	18	33	33
22253	19	31	33
22253	20	32	33
22255	9	31	22
22255	15	29	22
22255	16	4	22
22255	18	30	22
22255	19	28	22
22255	20	29	22
22256	9	6	7

INDEX

Parts No.	Page No.	Ref. No.	Weight (g)
22257	9	9	2.2
22259	2	27	1
22260	2	32	4
22261	2	25	0.5
22267	9	30	58
22268	15	28	56.6
22268	18	29	56.6
22268	19	27	56.6
22268	20	28	56.6
22269	16	1	7
22370	2	17	1
22371	2	34	0.55
22375	56	25	30
22376	54	50	17
22376	56	26	17
22377	54	51	7
22377	56	27	7
22392	44	16	60
22404	44	13	50
22410	40	49	34
22410	43	23	34
22416	45	5	2
22420	57	18	15
22421	57	22	8.3
22422	57	28	7.6
22423	57	26	1.25
22424	57	20	—
22425	57	19	10
22426	57	16	5.5
22430	25	13	56
22430	57	31	56
22431	25	16	11.6
22431	57	34	11.6
22432	25	14	7.5
22432	57	32	7.5
22433	25	22	11
22433	57	39	11
22434	25	20	19.1
22434	57	37	19.1
22435	16	35	0.45
22435	25	25	0.45
22435	57	42	0.45
22436	16	36	0.7
22436	25	26	0.7
22436	57	43	0.7
22437	25	23	0.56
22437	57	40	0.56
22439	16	19	—
22441	16	25	—
22442	16	42	—
22443	16	40	—
22444	16	39	—
22445	16	27	—
22446	16	31	—

Parts No.	Page No.	Ref. No.	Weight (g)
22447	16	33	—
22448	16	34	—
22492	41	2-2	—
22492	45	10-2	—
22493	41	4	—
22493	45	16	—
22494	41	5-1	—
22494	45	17-1	—
22495	41	5-2	—
22495	45	17-2	—
22496	41	6-2	—
22496	45	15-2	—
22497	41	6-1	—
22497	45	15-1	—
22519	15	38	2
22519	18	38	2
22519	19	36	2
22519	20	37	2
22519	33	22	2
22519	34	17	2
22519	58	14	2
22521	15	34	75
22523	19	32	75
22525	18	34	—
22527	20	33	75
22529	33	18	75
22531	34	21	75
22533	34	12	—
22535	34	14	—
22535	33	20	—
22580	5	7	460
22581	12	8	108
22584	6	41	17.7
22587	12	5	41.7
22588	12	4	43
22589	59	56	3.6
22591	5	1	166
22600	18	22-2	—
22600	34	5-2	—
22600	45	14-2	—
22601	18	26-2	—
22601	21	34-2	—
22602	34	11-2	—
22605	21	25-1	—
22605	45	20-1	—
22605	57	14-1	—
22606	21	25-2	—
22606	45	20-2	—
22607	18	26-1	—
22607	21	34-1	—
22608	18	27	—
22608	21	35	—
22609	57	49	—
22611	34	11-1	—

Parts No.	Page No.	Ref. No.	Weight (g)
22614	41	1	—
22616	6	33	0.17
22620	58	28	—
22621	58	29	—
22632	35	20	—
22635	36	1	14
22635	44	30	14
22635	53	1	14
22638	39	1-2	—
22652	39	11	75.2
22652	42	14	75.2
22653	39	2	205
22667	55	43	—
22669	54	49	12
22670	15	2	15
22671	15	13	—
22672	15	16	—
22673	15	15	—
22674	15	11	5
22687	39	6	—
22687	42	8	—
22746	2	50	121
22749	15	10	120
22758	2	42	35
22759	15	8	2.3
22760	2	14	18.3
22763	2	30	79
22764	2	24	2
22765	2	28	4.4
22766	2	22	2
22768	2	48	5.4
22769	4	33	2.4
22770	7	1	—
22771	7	2	—
22776	7	7	8.6
22777	7	6	0.8
22778	15	2	3.8
22781	58	1-1	—
22784	58	1-3	—
22785	58	1-4	—
22786	58	1-2	—
22787	58	16-1	—
22788	58	16-2	—
22789	58	10-1	—
22790	58	10-3	—
22791	58	10-2	—
22811	25	12	12
22812	25	29	17
22813	25	30	7
22814	25	4	—
22815	25	10	—
22815	33	27	—
22816	25	7	7
22816	33	26	7

INDEX

Parts No.	Page No.	Ref. No.	Weight (g)
22817	25	1	—
22819	33	25	—
22820	33	24	—
22822	25	31	5
22823	33	29	—
22835	3	34	20
22836	53	21	10.3
22836	56	13	10.3
22836	57	46	10.3
22837	53	23	—
22837	56	15	—
22837	57	48	—
22839	8	20	18.5
22844	11	1	—
22845	6	30	86
22852	12	25	6
22853	10	27	—
22856	57	1-1	—
22857	57	1-2	—
22858	57	1-3	—
22859	57	1-4	—
22860	57	1-5	—
22861	57	4-1	25
22862	57	4-2	—
22863	57	11	—
22864	57	1-6	—
22865	57	1-7	—
22866	57	1-8	—
22867	57	10-1	—
22868	57	10-2	—
22869	57	10-3	—
22880	57	15-1	—
22881	57	15-2	—
22883	57	15-3	—
22945	24	11	—
22947	22	14	—
22947	26	14	—
22947	29	14	—
22948	24	14	—
22950	24	24	—
22952	24	5	26
22952	31	4	26
22953	41	7	21
22954	24	20	28
22954	31	21	28
22955	41	8	23
22956	24	2	—
22956	31	7	—
22956	41	3	—
22956	45	11	—
22957	23	17	33
22959	24	21	19
22960	22	2	57
22960	26	2	57
22960	29	2	57

Parts No.	Page No.	Ref. No.	Weight (g)
22961	22	24	35.5
22961	26	24	35.5
22961	29	24	35.5
22962	22	22	15.4
22962	26	22	15.4
22962	29	22	15.4
22963	22	18	79
22963	26	18	79
22963	29	18	79
22964	22	12	30
22964	26	12	30
22964	29	12	30
22966	22	21	0.5
22966	26	21	0.5
22966	29	21	0.5
22967	22	11	28.5
22967	26	11	28.5
22967	29	11	28.5
22968	22	8	16.5
22968	26	8	16.5
22968	29	8	16.5
22970	23	10	21.6
22970	28	10	21.6
22970	30	10	21.6
22971	22	7	2
22971	26	7	2
22971	29	7	2
22972	22	17	15
22972	26	17	15
22972	29	17	15
22975	24	6	18
22975	23	15	18
22977	23	26	0.8
22980	24	18	—
22981	22	19	20
22981	26	19	20
22981	29	19	20
22982	23	49	16
22982	30	47	16
22983	31	5	13
22984	31	22	14
22985	31	11	—
22986	31	14	—
22987	22	1	—
22987	26	1	—
22987	29	1	—
22988	31	25	—
22990	31	18	—
22991	31	6	15
22992	31	23	16
23000	9	39-1	—
23002	9	39-2	—
23004	9	39-3	—
23006	9	39-4	—

Parts No.	Page No.	Ref. No.	Weight (g)
23008	33	13-1	—
23010	33	13-2	—
23012	33	13-3	—
23014	33	13-4	—
23016	45	1-1	—
23018	45	1-2	—
20020	45	1-3	—
23022	45	1-4	—
23024	15	18	—
23030	18	16-1	—
23032	18	16-2	—
23034	19	17-1	—
23036	19	17-2	—
23038	34	1-1	—
23040	34	1-2	—
23042	34	19-1	—
23044	34	19-2	—
23046	45	12-1	—
23048	45	12-2	—
23050	45	12-3	—
23052	45	12-4	—
23060	21	19-1	—
23062	21	19-2	—
23064	21	36-1	—
23066	21	36-2	—
23068	45	18-1	—
23070	45	18-2	—
23072	45	18-3	—
23074	45	18-4	—
23076	20	18-1	—
23078	20	18-2	—
23082	17	21	—
23084	27	32	—
23086	28	16	—
23094	17	6	—
23096	24	23	22
23112	24	8	21.5
23114	24	17	25.4
23136	24	25	23.5
23150	31	8	21.5
23154	31	24	22
23160	31	17	23
23164	31	26	23.5
23169	53	14	—
23169	56	5	—
23170	55	50	15.9
23171	55	51	7
23172	55	49-1	28.5
23173	55	44	2.3
23174	55	40	23
23175	35	19	—
23175	44	3	—
23175	52	19	—
23179	36	2	16.6
23179	44	34	16.6

INDEX

Parts No.	Page No.	Ref. No.	Weight (g)
23179	53	2	16.6
23180	53	11	47.8
23180	56	2	47.8
23181	53	16	4.8
23181	56	7	4.8
23182	53	18-1	1
23182	56	9-1	1
23184	53	13	0.16
23184	56	4	0.16
23185	37	10	282
23185	38	10	282
23185	46	10	282
23185	47	10	282
23185	54	10	282
23185	55	10	282
23186	37	26	6
23186	38	26	6
23186	46	26	6
23186	47	26	6
23186	54	26	6
23186	55	26	6
23187	37	23	4
23187	38	23	4
23187	46	23	4
23187	47	23	4
23187	54	23	4
23187	55	23	4
23188	37	13	6.8
23188	38	13	6.8
23188	46	13	6.8
23188	47	13	6.8
23188	54	13	6.8
23188	55	13	6.8
23189	37	18	25
23189	38	18	25
23189	47	18	25
23189	46	18	25
23189	54	18	25
23189	55	18	25
23190	37	29	26
23190	38	29	26
23190	46	29	26
23190	47	29	26
23190	54	29	26
23190	55	29	26
23191	35	3	18

23191	46	40	18
23191	47	40	18
23191	52	3	18
23192	38	1	750
23192	55	1	750
23193	2	12	17.5
23197	44	7	377

Parts No.	Page No.	Ref. No.	Weight (g)
23197	52	20-1	377
23198	37	1	—
23198	54	1	—
23201	56	12	—
23203	53	12	37.5
23203	56	3	37.5
23205	52	20-2	377
23206	56	1	—
23208	54	44	—
23209	54	40	23
23211	56	22	—
23212	56	16	—
23220	40	41	—
23220	43	14	—
22223	55	49-2	28.5
23360	40	28	—
23361	40	40	—
23361	43	13	—
23364	40	33	—
23364	43	6	—
23367	40	31	—
23367	43	4	—
23368	40	36	—
23368	43	9	—
23369	40	35	—
23369	43	8	—
23370	40	42	—
23370	43	15	—
23371	40	38	—
23371	43	11	—
23372	40	45	—
23372	43	18	—
23373	40	46	—
23373	43	20	—
23374	40	29	—
23374	43	2	—
23375	39	20	—
23375	42	22	—
23376	40	61	—
23378	40	66	—
23378	44	38	—
23380	42	1	—
23381	39	9	—
23382	43	31	—
23383	43	19	—
23386	43	1	—
23390	39	1-1	—
23393	44	8	—
23397	43	26	—
23399	40	43	—
23399	43	16	—
23412	44	2	—
23441	41	2-1	—

Parts No.	Page No.	Ref. No.	Weight (g)
23441	45	10-1	—
23442	41	2-3	—
23442	45	10-3	—
23443	41	2-4	—
23443	45	10-4	—
23447	39	17	—
23447	42	19	—
23460	6	34	—
23461	6	29	—
23465	8	16	—
23466	4	13	—
23467	18	1	—
23467	19	1	—
23467	20	1	—
23467	21	1	—
23467	23	1	—
23467	28	1	—
23467	30	1	—
23468	10	37	—
23470	10	10	—
23473	13	23	—
23490	46	1	—
23491	47	1	—
23700	48	46	—
23701	49	29	—
23703	49	32	—
23704	49	31	—
23705	49	18	—
23707	49	17	—
23708	49	20	—
23709	49	23	—
23710	49	25	—
23711	48	24	—
23712	48	43	—
23713	48	45	—
23714	48	1	—
23715	48	7	—
23717	48	3	—
23718	48	41	—
23720	51	6	—
23722	48	34	—
23723	48	28	—
23724	49	16	—
23725	48	13	—
23726	48	3	—
23727	50	1	—
23728	50	20	—
23729	50	3	—
23730	51	7	—
23732	50	13	—
23734	51	2	—
23737	49	21	—
23739	49	2	—
23740	49	1	—

INDEX

Parts No.	Page No.	Ref. No.	Weight (g)
23741	49	3	—
23744	49	6	—
23745	49	12	—
23747	49	15	—
23748	51	35-2	—
23749	51	34	—
23750	48	4	—
23752	48	17	—
23754	49	28	—
23756	49	26	—
23759	51	35-1	—
23763	48	5	—
23765	51	35-3	—
23766	50	15	—
23767	49	34	—
23768	49	35	—
23769	48	8	—
23770	51	31-1	—
23771	51	31-2	—
23772	51	31-3	—
23776	50	2	—
23778	51	9	—
24029	8	31	8
24040	2	1	78
24046	40	65	31
24046	44	37	31
24067	13	14	—
24073	3	16	16
24074	2	3	587
24075	2	6	7
24076	2	10	0.5
24080	9	13	10
24091	3	4	—
24092	3	3	0.5
24093	3	1	36
24119	12	36	—
24120	12	33	—
24121	12	32	—
24122	12	46	—
23134	2	43	—
24166	14	17	0.1
24167	14	18	2
24169	11	22	2.6
24183	12	28	17
24184	12	30	—
24191	10	1	—
24193	10	6	10
24194	10	3	5
24195	10	7	5
24254	51	30	10
24301	35	21	—
24301	52	21	—
24303	35	1	—
24303	52	1	—

Parts No.	Page No.	Ref. No.	Weight (g)
23343	23	46	—
24343	30	44	—
24460	27	4	—
24460	30	17	—
24461	27	1	—
24461	30	14	—
24462	23	36	—
24462	27	22	—
24462	30	34	—
24463	23	24	—
24463	27	9	—
24463	30	22	—
24464	23	37	—
24464	27	23	—
24464	30	35	—
24465	23	40	—
24465	27	26	—
24465	30	38	—
24466	23	38	—
24466	27	24	—
24466	30	36	—
24470	23	19	—
24471	23	14	—
24481	10	23	—
24482	10	14	—
24483	10	13	—
24484	10	22	—
24485	10	15	—
26312	39	18	—
26312	42	20	—
30080	59	29	—
30228	1	23	9
30228	12	37	9
30255	16	2	2.7
30255	18	4	2.7
30255	19	6	2.7
30255	20	6	2.7
30255	21	4	2.7
30255	23	4	2.7
30255	28	4	2.7
30255	30	4	2.7
30255	38	35	2.7
30255	47	35	2.7
30255	55	35	2.7
30291	5	36	1
30745	14	3	0.4
30748	14	4	0.7
31111	4	6	5
31111	18	7	5
31111	19	9	5
31111	20	9	5
31111	21	7	5
31111	23	7	5
31111	28	7	5

Parts No.	Page No.	Ref. No.	Weight (g)
31111	30	7	5
31111	37	7	5
31111	38	7	5
31111	46	7	5
31111	47	7	5
31111	50	9	5
31111	54	7	5
31111	55	7	5
32421	1	29	0.1
32421	59	45	0.1
32604	6	53	0.9
32612	2	7	0.25
32612	3	40	0.25
32646	6	8	12
32646	8	8	12
32684	5	21	1
32779	5	4	2.4
32812	10	36	0.01
32865	13	1	—
32867	13	3	4.7
32919	8	30	1
32920	8	11	15.5
32920	12	3	15.5
32921	6	3	7
32921	8	3	7
32944	14	32	2
32949	14	38	—
32971	37	22	2
32971	38	22	2
32971	46	22	2
32971	47	22	2
32971	54	22	2
32971	55	22	2
33013	3	22	14
33024	3	33	0.1
33081	2	52	0.6
33098	12	12	14.4
33099	12	16	3.6
33118	12	40	24
33131	3	31	1.1
33141	13	4	11
33394	23	43	15.5
33394	27	29	15.5
33394	30	41	15.5
33397	23	21	15.5
33397	27	6	15.5
33397	30	19	15.5
33398	27	11	1.06
33398	30	24	1.06
33471	33	15	1
33471	34	8	1
33471	57	5-2	1
33588	32	37	1.1
33668	14	36	1

INDEX

Parts No.	Page No.	Ref. No.	Weight (g)
33711	53	18-2	0.8
33711	56	9-2	0.8
33738	21	17	0.09
33806	37	2	2
33806	38	2	2
33806	46	2	2
33806	47	2	2
33806	54	2	2
33806	55	2	2
33807	37	5	3
33807	38	5	3
33807	46	5	3
33807	47	5	3
33807	54	5	3
33807	55	5	3
33890	4	2	1.2
33890	19	5	1.2
33890	20	5	1.2
33890	18	3	1.2
33890	21	3	1.2
33890	23	3	1.2
33890	28	3	1.2
33890	30	3	1.2
33890	37	3	1.2
33890	38	3	1.2
33890	46	3	1.2
33890	47	3	1.2
33890	50	5	1.2
33890	54	3	1.2
33890	55	3	1.2
33925	32	1	425
33928	32	2	—
33931	32	6	7.7
33932	32	20	15
33932	44	14	15
33933	32	23	87
33934	32	18	64
33935	32	15	11
33936	32	14	15
33937	32	13	5
33938	32	11	7
33939	32	21	12
33939	44	15	12
33940	32	5	13
33941	32	19	43
33942	32	22	355
33949	32	7	4.6
33950	32	9	3
33951	32	8	0.1
33953	32	10	156
33980	14	41	—
34118	11	11	1.8
34293	9	32	0.06
34293	15	30	0.06
34293	16	5	0.06

Parts No.	Page No.	Ref. No.	Weight (g)
34293	18	31	0.06
34293	19	29	0.06
34293	20	30	0.06
34294	9	7	0.35
34505	1	9	4
34510	1	15	0.8
34535	9	43	1.4
34535	15	22	1.4
34535	17	10	1.4
34535	18	20	1.4
34535	19	21	1.4
34535	20	22	1.4
34535	21	23	1.4
34535	24	12	1.4
34535	25	5	1.4
34535	27	36	1.4
34535	28	20	1.4
34535	31	12	1.4
34535	54	47	1.4
34535	55	47	1.4
34535	56	20	1.4
34535	57	5-1	1.4
34535	58	5	1.4
34637	1	5	12
34867	16	21	22
34979	22	3	1.5
34979	26	3	1.5
34979	29	3	1.5
35149	1	31	215
35150	1	32	6
35298	39	22	17.5
35298	42	26	17.5
35719	40	55	1.8
36719	43	33	1.8
35722	40	59	—
35722	43	37	—
36111	48	21	—
36132	48	22	2
36133	35	6	1
36133	42	11	1
36133	48	33	1
36133	52	6	1
36161	49	9	—
36853	37	9	6
36853	38	9	6
36853	46	9	6
36853	47	9	6
36853	54	9	6
36853	55	9	6
36907	58	31	—
36908	58	33	—
36909	58	36	—
37114	50	17	0.54
37668	14	37	4.25

Parts No.	Page No.	Ref. No.	Weight (g)
37912	58	35	—
77322	13	19	9
77366	1	26	2.4
77432	10	29	0.3
80503	14	5	0.2
80504	57	27	0.2
92232	51	24	262
93864	7	21	0.05
94491	35	13	0.2
94491	40	60	0.2
94491	43	38	0.2
94491	44	10	0.2
94491	48	23	0.2
94491	52	13	0.2
95134	5	35	11.5
99030	59	16	11.5
99031	59	17	—
99057	59	2	—
99058	59	3	—
99059	59	4-2	—
99060	59	4-1	—
99061	59	7	—
99062	59	10	—
99063	59	13	—
99064	59	18	—
99065	59	20	—
99066	59	21	—
99067	59	23	—
99068	59	24	—
99069	59	25	—
99070	59	28-1	—
99071	59	28-2	—
99072	59	1-1	—
99073	59	1-2	—

INDEX

Page	Page	Page	Page	Page	Page	Page	Page	Page	Page
1	11	21	31	41	51	61	71	81	91
101	111	121	131	141	151	161	171	181	191
201	211	221	231	241	251	261	271	281	291
301	311	321	331	341	351	361	371	381	391
401	411	421	431	441	451	461	471	481	491
501	511	521	531	541	551	561	571	581	591
601	611	621	631	641	651	661	671	681	691
701	711	721	731	741	751	761	771	781	791
801	811	821	831	841	851	861	871	881	891
901	911	921	931	941	951	961	971	981	991

